

Dimensioned drawing

ISS 212...-2E0-S12  
ISS 212...-4E0-S12

ISS 212...-6E0-S12

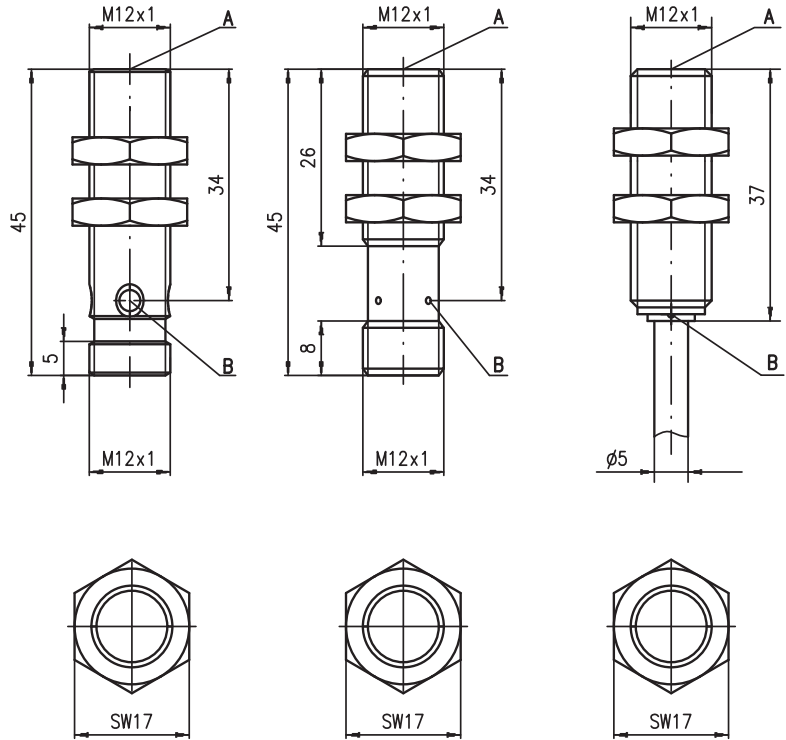

Tightening torque of the fastening nuts < 10Nm !

- A Active surface
- B Yellow indicator diode

Electrical connection

Cable

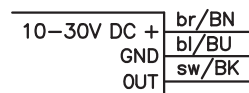

M12 connector

...NO... (normally open)

...NC... (normally closed)

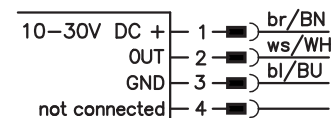
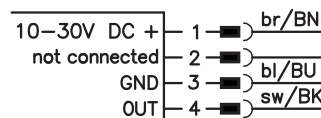

...NO...-S12 (normally open):  
...NC...-S12 (normally closed):

3-pin or 4-pin M12 connection cables can be used.  
only 4-pin M12 connection cables can be used.

en 03-2016/05 50110222



M12  
2 mm  
4 mm  
6 mm



embedded

- Slim and very short cylindrical metal housing M12
- Chromium-plated brass housing
- Built-in short circuit protection, inductive protection and polarity reversal protection
- LED for switching state visible from 360°

We reserve the right to make changes • DS\_ISS212E\_en\_50110222.fm



Accessories:

(available separately)

- M12 connectors (KD ...)
- Ready-made cables (K-D ...)
- Mounting clamp (MC 012...)

## Specifications

General specifications	ISS 212...-2E0...	ISS 212...-4E0...	ISS 212...-6E0...
Type of installation	embedded installation		
Typ. operating range limit $S_n$	2.0mm	4.0mm	6.0mm
Operating range $S_a$	0 ... 1.6mm	0 ... 3.2mm	0 ... 4.8mm
<b>Electrical data</b>			
Operating voltage $U_B$ 1)	10 ... 30VDC		
Residual ripple $\sigma$	$\leq 20\%$ of $U_B$		
Output current $I_L$	$\leq 200\text{mA}$		
Open-circuit current $I_0$	$\leq 10\text{mA}$		
Residual current $I_r$	$\leq 100\mu\text{A}$		
Switching output/function	.../4NO...	PNP transistor, make-contact (NO)	
	.../4NC...	PNP transistor, break-contact (NC)	
	.../2NO...	NPN transistor, make-contact (NO)	
	.../2NC...	NPN transistor, break-contact (NC)	
Voltage drop $U_d$	$\leq 2\text{V}$		
Hysteresis H of $S_r$	$\leq 10\%$	$\leq 15\%$	$\leq 10\%$
Temperature drift of $S_r$	$\leq 10\%$ 2)		
Repeatability	$\leq 5\%$ 3)		
<b>Timing</b>			
Switching frequency f	3kHz	2kHz	800Hz
Delay before start-up	$\leq 10\text{ms}$	$\leq 300\text{ms}$	$\leq 50\text{ms}$
<b>Indicators</b>			
Yellow LED (visible from 360°)	switching state		
<b>Mechanical data</b>			
Housing	chromium-plated brass		
Standard surface plate	12 x 12mm <sup>2</sup> , Fe360	12 x 12mm <sup>2</sup> , Fe360	18 x 18mm <sup>2</sup> , Fe360
Active surface	PBTP		
Weight (M12 plug/cable)	approx. 25g/ approx. 95g		
Connection type	M12 connector 4-pin or cable: 2m, PVC, 3 x 0.34mm <sup>2</sup> , $\varnothing$ 5.0mm		
<b>Environmental data</b>			
Ambient temperature	-25°C ... +70°C		
Protection class	IP 67		
Protective circuit 4)	1, 2, 3		
Standards applied	IEC/EN 60947-5-2		
Electromagnetic compatibility	IEC 60255-5	1kV	
	IEC 61000-4-2	Level 3 air 8kV (ESD)	
	IEC 61000-4-3	Level 3 10V/m (RFI)	
	IEC 61000-4-4	Level 3 2kV (Burst)	

- 1) Observe the safety regulations and installation instructions regarding power supply and wiring; for UL applications: only for use in "Class 2" circuits acc. to NEC
- 2) Over the entire operating temperature range
- 3) For  $U_B = 20 \dots 30\text{VDC}$ , ambient temperature  $T_a = 23^\circ\text{C} \pm 5^\circ\text{C}$
- 4) 1=polarity reversal protection, 2=short circuit protection, 3=inductive protection for all outputs

## Diagrams

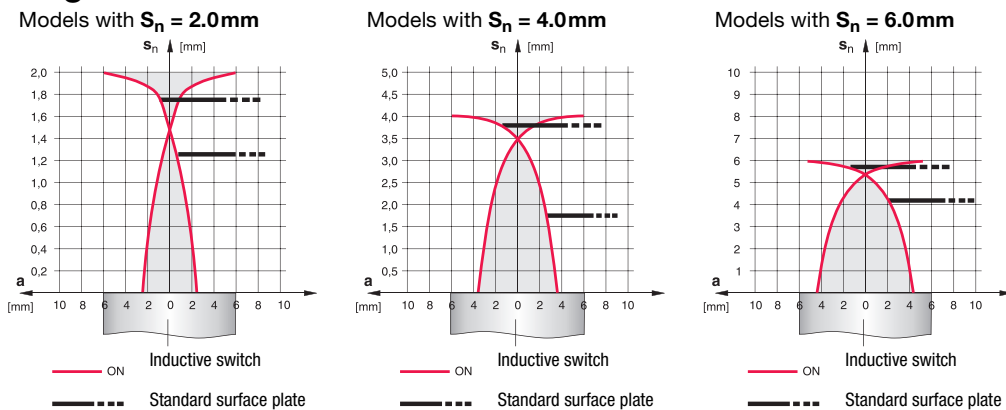

## Tables

Reduction factors:

for $S_n = 2.0\text{mm}$		for $S_n = 4.0\text{mm}$	
Steel Fe360	1	Steel Fe360	1
Copper	0.20	Copper	0.40
Aluminum	0.30	Aluminum	0.44
Brass	0.40	Brass	0.54
Stainless steel	0.85	Stainless steel	0.80

for  $S_n = 6.0\text{mm}$

Steel Fe360	1
Copper	0.25
Aluminum	0.30
Brass	0.40
Stainless steel	0.70

## Mounting

### Embedded installation:

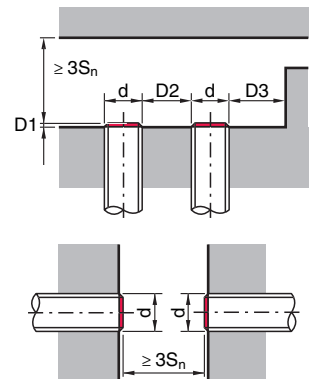

Ferromagnetic and non-ferromagnetic materials			
$S_n$ [mm]	D1 [mm]	D2 [mm]	D3 [mm]
2.0	0	6.0	2.0
4.0	0	12.0	4.0
6.0	2.0	18.0	6.0

## Remarks

### Operate in accordance with intended use!

- ⚠ This product is not a safety sensor and is not intended as personnel protection.
- ⚠ The product may only be put into operation by competent persons.
- ⚠ Only use the product in accordance with the intended use.

## Type key

I	S	S	2	1	2	M	M	/	4	N	O	-	4	E	O	-	S	1	2
---	---	---	---	---	---	---	---	---	---	---	---	---	---	---	---	---	---	---	---

**Operating principle / construction**

**ISS** Inductive switch / short construction

**Series**

**212** series with M12 x 1 external thread

**Housing / thread**

**MM** metal housing (active surface: plastic) / metric thread

**Output function**

**4NO** PNP transistor, make-contact (NO)

**4NC** PNP transistor, break-contact (NC)

**2NO** NPN transistor, make-contact (NO)

**2NC** NPN transistor, break-contact (NC)

**Measurement range / type of installation**

**2E0** typ. scan range limit 2.0mm / embedded installation

**4E0** typ. scan range limit 4.0mm / embedded installation

**6E0** typ. scan range limit 6.0mm / embedded installation

**Electrical connection**

**N/A** cable, PVC, standard length 2000mm

**S12** M12 connector, 4-pin, axial

**200-S12** cable, PVC, length 200mm with M12 connector, 4-pin, axial

## Order guide

The sensors listed here are preferred types; current information at [www.leuze.com](http://www.leuze.com).

	<b>Designation</b>	<b>Part No.</b>
<b>S<sub>n</sub> = 4mm</b>	ISS 212 MM/4NO-4E0	50109684
	ISS 212 MM/4NO-4E0-S12	50109685
	ISS 212 MM/4NC-4E0	50129359
	ISS 212 MM/4NC-4E0-S12	50109676
	ISS 212 MM/2NO-4E0-S12	50109687
	ISS 212 MM/2NC-4E0-S12	50111741
<b>S<sub>n</sub> = 6mm</b>	ISS 212 MM/4NO-6E0-S12	50109679
	ISS 212 MM/4NC-6E0-S12	50133409
	ISS 212 MM/2NO-6E0-S12	50109688

