

RKR 3B Foils + Glass panes

Retro-reflective photoelectric sensor

en 10-2014/05 50105367-01



Dimensioned drawing

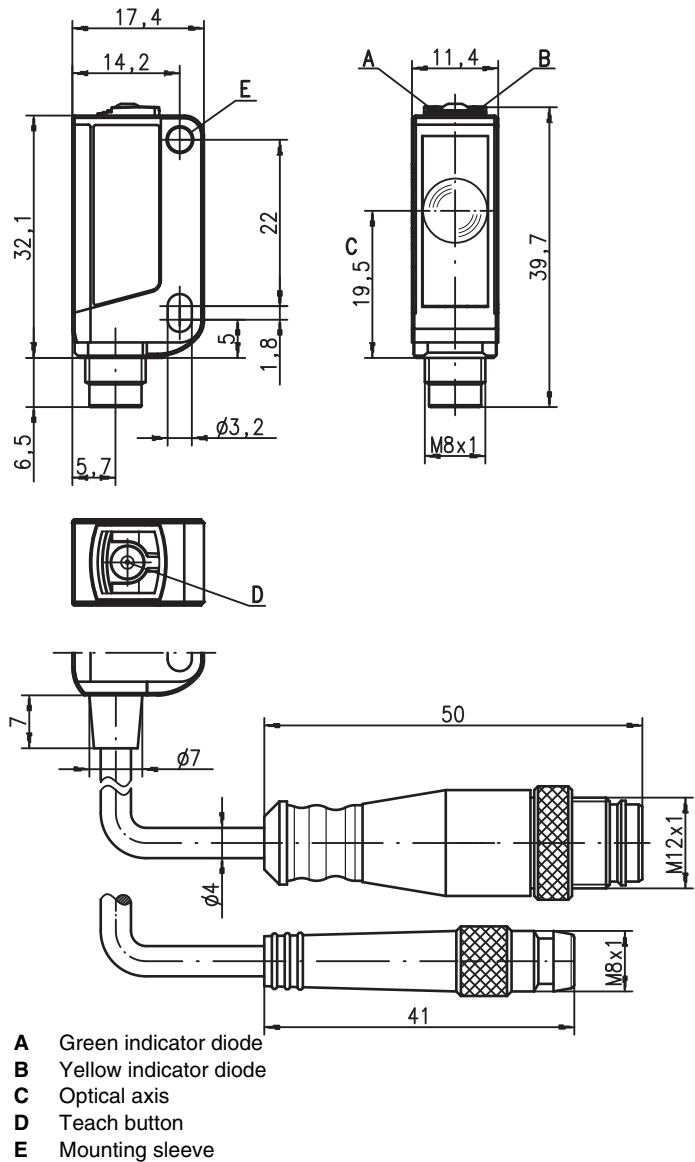

0 ... 1.8m
1 kHz
T_i
10 - 30 V DC
A²LS
SPS
PLC

- Retro-reflective photoelectric sensor with visible red laser light and autocollimation principle
- Especially for highly transparent foils glass panes
- Small and compact construction with robust plastic housing, protection class IP 67/ IP 69K for industrial application
- Push-pull output with light/dark switching via teach-in button
- High switching frequency for detection of fast events
- Easy adjustment via lockable teach button or teach input
- May also be used with glass reflectors (TG)

Electrical connection

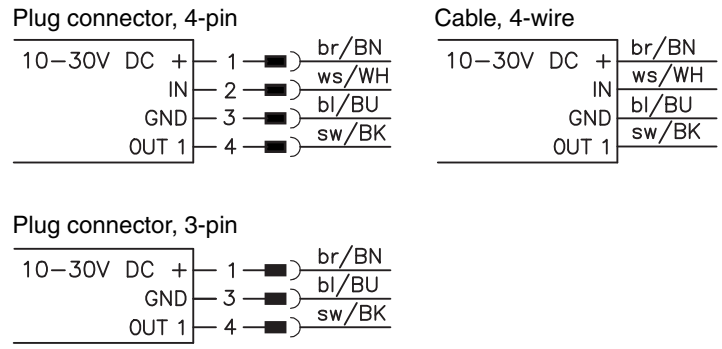

Accessories:

- (available separately)
- Mounting systems (BT 3...)
 - Cables with M8 or M12 connector (K-D ...)
 - Reflectors
 - Reflective tapes

We reserve the right to make changes • DS_RKR3B642_en_50105367_01.fm

Specifications

Optical data

Typ. op. range limit (TK(S) 100x100) ¹⁾ 0 ... 1.8m
 Operating range ²⁾ see tables
 Light source ³⁾ LED (modulated light)
 Wavelength 620nm (visible red light)

Timing

Switching frequency 1,000Hz
 Response time 0.5ms
 Delay before start-up ≤ 300ms

Electrical data

Operating voltage U_B ⁴⁾ 10 ... 30VDC (incl. residual ripple)
 Residual ripple ≤ 15% of U_B
 Open-circuit current ≤ 15mA
 Switching output ⁵⁾ .../6.42 1 push-pull switching output
 pin 4: PNP light switching, NPN dark switching
 pin 2: teach input
 .../6.42...-S8.3 1 push-pull switching output
 pin 4: PNP light switching, NPN dark switching
 pin 2: activation input, light switching
 .../4.48 1 PNP switching output, light switching
 pin 2: activation input
 light/dark reversible
 Signal voltage high/low $\geq (U_B - 2V) \leq 2V$
 Output current max. 100mA
 Operating range setting via teach-in

Indicators

Green LED ready
 Yellow LED light path free

Mechanical data

Housing plastic (PC-ABS), 1 attachment sleeve, nickel-plated steel
 Optics cover plastic (PMMA)
 Weight with connector: 10g
 with 200mm cable and connector: 20g
 with 2m cable: 50g
 2m cable (cross section 4x0.20mm²),
 connector M8 metal,
 0.2m cable with connector M8 or M12

Connection type

Environmental data

Ambient temp. (operation/storage) -30°C ... +55°C/-30°C ... +70°C
 Protective circuit ⁶⁾ 2, 3
 VDE safety class II for cable ⁷⁾,
 III for metal plug
 Protection class IP 67, IP 69K
 Light source exempt group (in acc. with EN 62471)
 Standards applied IEC 60947-5-2
 Certifications UL 508, C22.2 No.14-13 ⁸⁾

Options

Teach-in input/activation input

Transmitter active/not active $\geq 8V \leq 2V$
 Activation/disable delay ≤ 1ms
 Input resistance 30kΩ

- 1) Typ. operating range limit: max. attainable range without performance reserve
- 2) Operating range: recommended range with performance reserve
- 3) Average life expectancy 100,000h at an ambient temperature of 25°C
- 4) For UL applications: for use in class 2 circuits according to NEC only
- 5) The push-pull switching outputs must not be connected in parallel
- 6) 2=polarity reversal protection, 3=short circuit protection for all transistor outputs
- 7) Rating voltage 50V
- 8) These proximity switches shall be used with UL Listed Cable assemblies rated 30V, 0.5A min, in the field installation, or equivalent (categories: CYJV/CYJV7 or PVVA/PVVA7)

Remarks

Adapter plate:

BT 3.2 (part no. 501 03844) for alternate mounting on 25.4 mm hole spacing (Omron E3Z, Sick W100...)

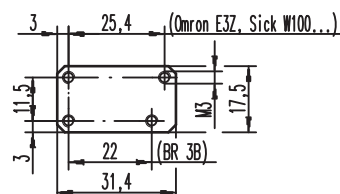

Tables

Reflectors			Operating range
1	TK(S)	100x100	0 ... 1.5m
2	TK	40x60	0 ... 1.0m
3	MTKS	50x50.1	0 ... 1.0m
4	Tape 6	50x50	0 ... 0.6m
5	TK	20x40	0 ... 0.5m

1	0	1.5	1.8
2	0	1	1.2
3	0	1	1.2
4	0	0.6	0.7
5	0	0.5	0.6

□ Operating range [m]
 ▒ Typ. operating range limit [m]

TK ... = adhesive
 TKS ... = screw type
 MTKS ... = micro triple, screw type

Diagrams

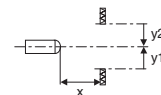
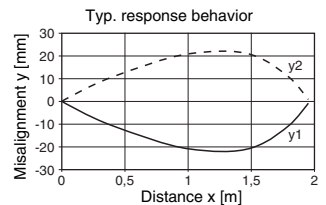

Remarks

Operate in accordance with intended use!

- ⚠ This product is not a safety sensor and is not intended as personnel protection.
- ⚠ The product may only be put into operation by competent persons.
- ⚠ Only use the product in accordance with the intended use.

Mounting system:



- ① = BT 3 (part no. 500 60511)
- ②+③ = BT 3.1 ¹⁾ (part no. 501 05585)
- ①+②+③ = BT 3B (part no. 501 05546)

1) Packaging unit: PU = 10 pcs.

Order guide

Selection table			Order code →							
Equipment ↓			RKR 3B/6.42 Part No. 50104702	RKR 3B/6.42-S8 Part No. 50104703	RKR 3B/6.42, 200-S8 Part No. 50104704	RKR 3B/6.42, 200-S12 Part No. 50105763	RKR 3B/6.42-S8.3 on request	RKR 3B/6.42, 200-S8.3 on request	RKR 3B/6D.42 Part No. 50107914	
Output 1 (OUT 1)	push-pull switching output, configurable	light switching ○	● ¹⁾	● ¹⁾	● ¹⁾	● ¹⁾	● ¹⁾	● ¹⁾	●	
		dark switching ●	●	●	●	●	●	●	● ¹⁾	
	PNP transistor output	light switching ○								
		dark switching ●								
Input (IN)	teach input		●	●	●	●			●	
	activation input									
Connection	cable 2,000mm	4-wire	●						●	
	M8 connector, metal	3-pin					●			
	M8 connector, metal	4-pin		●						
	200mm cable with M8 connector	3-pin						●		
	200mm cable with M8 connector	4-pin			●					
	200mm cable with M12 connector	4-pin				●				
Configuration	Teach-in via button (lockable) and teach input		●	●	●	●			●	
	Teach-in via button						●	●		
Special area of application	optimized for detection of foils < 20µm		●	●	●	●	●	●	●	
	optimized for detection of PET and glass bottles									

1) Presetting, light/dark switching, adjustable

General information

- The light spot may not exceed the reflector.
- Preferably use MTK(S) or tape 6.
- For foil 6, the sensor's side edge must be aligned parallel to the side edge of the reflective tape.
- For reflecting objects, the sensor has to be mounted approx. 5° angular towards the object.

Sensor adjustment (teach) via teach button



- **Prior to teaching:**
Clear the light path to the reflector!
The device setting is stored in a fail-safe way. A reconfiguration following voltage interruption or switch-off is thus not required.

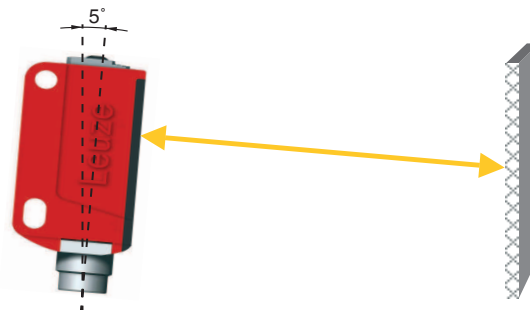

Standard teaching for average sensor sensitivity for bottle detection

- Press teach button until both LEDs flash **simultaneously**.
- Release teach button.
- Ready – bottles can be detected.



If the receive signal from the reflector is too weak, the sensor indicates the error status by means of fast and simultaneous flashing of the green and yellow LEDs. Please check the alignment, operating range, and soiling and carry out another teaching.

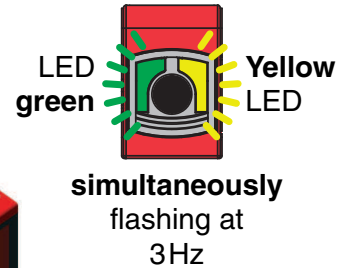
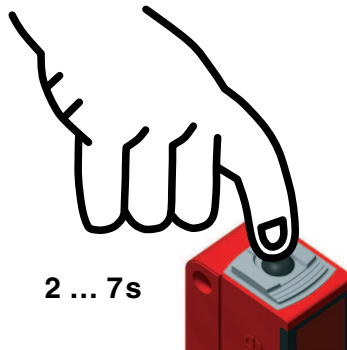

Teaching for increased sensor sensitivity for foil detection

- Press teach button until both LEDs flash **alternatingly**.
- Release teach button.
- Ready – fails can be detected.



If the receive signal from the reflector is too weak, the sensor indicates the error status by means of fast and simultaneous flashing of the green and yellow LEDs. Please check the alignment, operating range, and soiling and carry out another teaching.

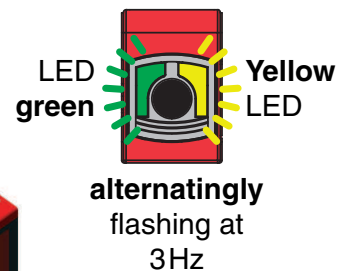
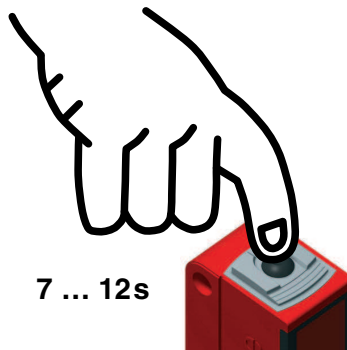

Adjusting the switching behavior of the switching output – light/dark switching

- Press teach button until the green LED flashes. The yellow LED displays the current setting of the switching output:
ON = output switches on light
OFF = output switches on dark
- Continue to press the teach button in order to change the switching behavior.
- Release teach button.
- Ready.

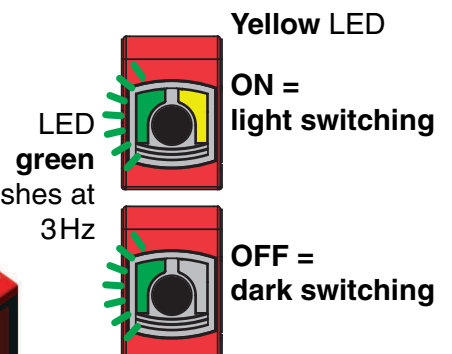
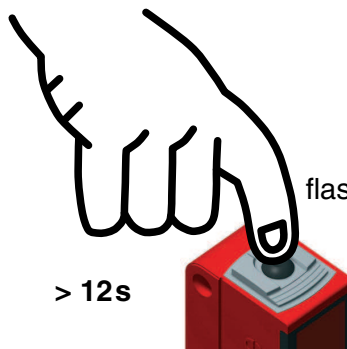

Locking the teach button via the teach input



A **static HIGH signal** ($\geq 4\text{ms}$) at the teach input locks the teach button on the device if required, such that no manual operation is possible (e.g., protection from erroneous operation or manipulation).

If the teach input is not connected or if there is a static low signal, the button is unlocked and can be operated freely.

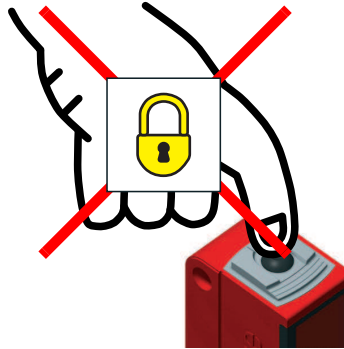

Sensor adjustment (teach) via teach input



The following description applies to PNP switching logic!

$U_{\text{Teach low}} \leq 2\text{V}$

$U_{\text{Teach high}} \geq (U_B - 2\text{V})$

Prior to teaching: Clear the light path to the reflector!

The device setting is stored in a fail-safe way. A reconfiguration following voltage interruption or switch-off is thus not required.

Standard teaching for average sensor sensitivity for bottle detection

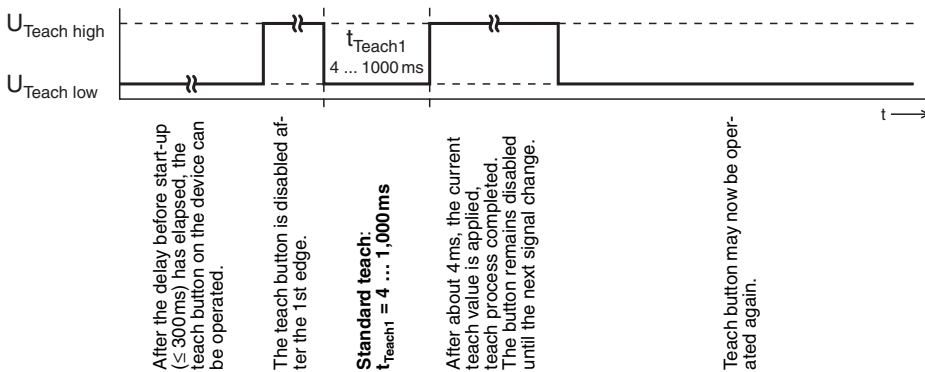

Quick standard teach

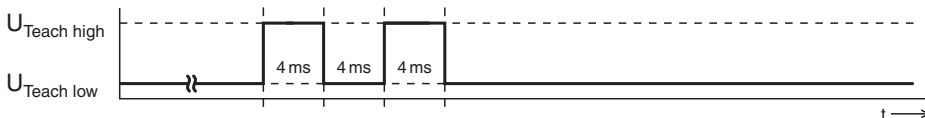

Shortest teaching duration for standard teaching: approx. 12ms



If the receive signal from the reflector is too weak, the sensor indicates the error status by means of fast and simultaneous flashing of the green and yellow LEDs. Please check the alignment, operating range, and soiling and carry out another teaching.

Teaching for increased sensor sensitivity for foil detection

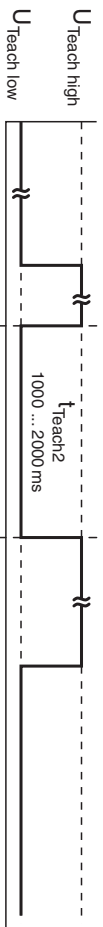

After the delay before start-up ($\leq 300\text{ms}$) has elapsed, the teach button on the device can be operated.

The teach button is disabled after the 1st edge.

Teach for increased sensor operating range:
 $t_{\text{Teach}2} = 1,000 \dots 2,000\text{ms}$

After about 4ms, the current teach value is applied, teach process completed. The button remains disabled until the next signal change.

Teach button may now be operated again.



If the receive signal from the reflector is too weak, the sensor indicates the error status by means of fast and simultaneous flashing of the green and yellow LEDs. Please check the alignment, operating range, and soiling and carry out another teaching.

Adjusting the switching behavior of the switching output – light/dark switching

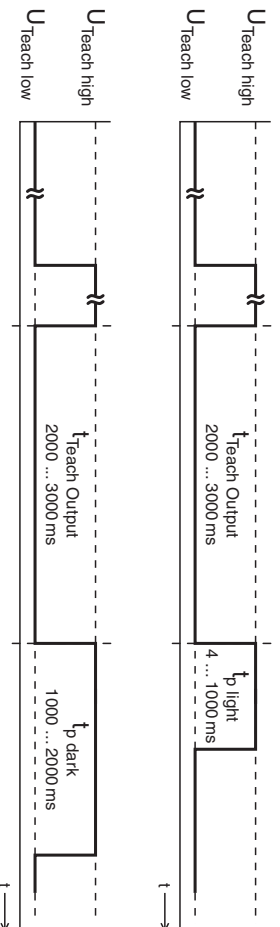

After the delay before start-up ($\leq 300\text{ms}$) has elapsed, the teach button on the device can be operated.

The teach button is disabled after the 1st edge.

Setting the switching behavior of the switching output:

$t_{\text{Teach Output}} = 2,000 \dots 3,000\text{ms}$

Switching output switches on light:

$t_{\text{p light}} = 4 \dots 1,000\text{ms}$

Switching output switches on dark:

$t_{\text{p dark}} = 1,000 \dots 2,000\text{ms}$

The button remains disabled until the next signal change.