

en 02-2015/09 50128317-01

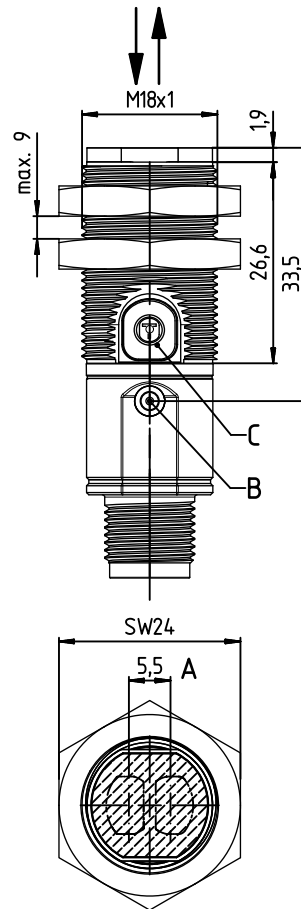

Dimensioned drawing



- A Optical axes
- B Indicator diode
- C Teach button



80 ... 150mm



- Reflection light scanner for the detection of labels on bottles
- Easy setting via teach-in
- Infrared light
- Active suppression of extraneous light A²LS
- Embedded mounting option
- Full control through green and yellow indicator LEDs
- Sturdy plastic housing with stainless steel threaded sleeve with cylindrical M18x1 design

Electrical connection

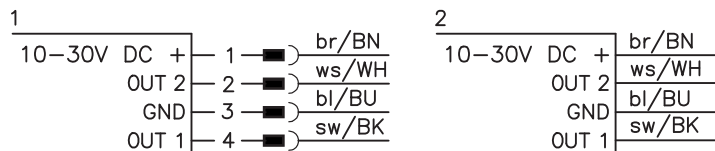

Accessories:

(available separately)

- Mounting systems (BTU D18M-D12, BT D18M.5)
- M12 connectors (KD ...)
- Ready-made cables (K-D ...)

We reserve the right to make changes • DS_FT328I_P1_en_50128317_01.fm



Specifications

Optical data

Scanning range limit ¹⁾	80 ... 150mm
Scanning range ²⁾	80 ... 120mm
Light source	LED (modulated light)
Wavelength	850nm (infrared light)

Timing

Switching frequency	500Hz
Response time	1ms
Delay before start-up	≤ 300ms

Electrical data

Operating voltage U_B ³⁾	10 ... 30VDC (incl. residual ripple)
Residual ripple	≤ 15% of U_B
Open-circuit current	≤ 20mA
Switching output	.../4P... 2 PNP transistor outputs pin 2: PNP dark switching, pin 4: PNP light switching .../2N... 2 NPN transistor outputs pin 2: NPN dark switching, pin 4: NPN light switching
Signal voltage high/low	≥ ($U_B - 2.5V$) / ≤ 2.5V
Output current	max. 100mA ⁴⁾

Indicators

Green LED	ready
Yellow LED	reflection (object detected)

Mechanical data

Housing	plastic with stainless steel threaded sleeve
Optics cover	plastic
Weight	30g with M12 connector 80g with 2m cable
Connection type	M12 connector, 4-pin cable 2m, 4x0.20mm ²

Environmental data

Ambient temp. (operation/storage)	-40°C ... +60°C / -40°C ... +70°C
Protective circuit ⁵⁾	2, 3
VDE safety class	III
Degree of protection	IP 67
Light source	exempt group (in acc. with EN 62471)
Standards applied	IEC 60947-5-2
Certifications	UL 508, C22.2 No.14-13 ³⁾ 6)

- 1) Scanning range limit: typical scanning range
- 2) Scanning range: ensured scanning range
- 3) For UL applications: for use in class 2 circuits according to NEC only
- 4) Sum of the output currents for both outputs, 50mA when ambient temperatures > 40°C
- 5) 2=polarity reversal protection, 3=short circuit protection for all outputs
- 6) These proximity switches shall be used with UL Listed Cable assemblies rated 30V, 0.5A min, in the field installation, or equivalent (categories: CYJV/CYJV7 or PVVA/PVVA7)

Mounting instructions

The sensor must be oriented at an angle of approx. 30 degrees to horizontal. We recommend using our **BTU D18M-D12** mounting system (part no. 50117490).

Adjustment and alignment

Push the BTU without sensor onto the rod, slightly tighten both screws and set the inclination to approx. 30 degrees. To do this, measure the distance from the upper edge of the clamp to the inner edge of the mounting bracket. The desired inclination is reached at 42mm. Align the sensor so that the emitted light strikes the center of the bottle. Tighten both screws on the BTU and screw the sensor into the support as shown in the drawing. Recheck the distance of 80 ... 120mm and the setting.

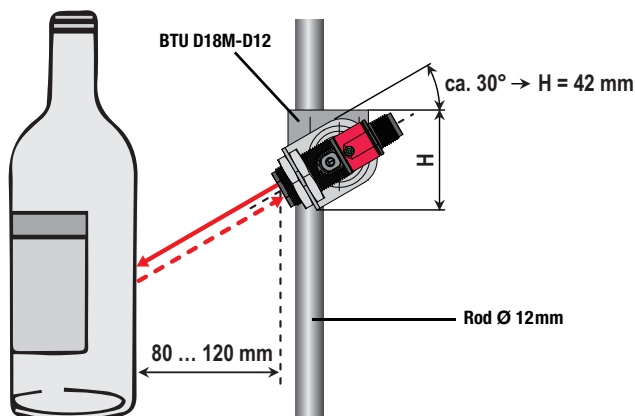

Tables

Diagrams

Remarks

Operate in accordance with intended use!

- ⚠ This product is not a safety sensor and is not intended as personnel protection.
- ⚠ The product may only be put into operation by competent persons.
- ⚠ Only use the product in accordance with the intended use.

The sensor is used for the detection of labels (paper or foil, adhesive or sleeve) on transparent containers (bottles and glasses; all types of glass, empty or full) at typical distance of 80 ... 120mm.

Order guide

The sensors listed here are preferred types; current information at www.leuze.com.

		Designation	Part no.
Sensors with axial optics			
With M12 connector	Pin 4: PNP light switching, pin 2: PNP dark switching	FT328I.3/4P-M12P1	50127773
	Pin 4: NPN light switching, pin 2: NPN dark switching	FT328I.3/2N-M12P1	on request
With cable, 2m	Pin 4: PNP light switching, pin 2: PNP dark switching	FT328I.3/4PP1	on request
	Pin 4: NPN light switching, pin 2: NPN dark switching	FT328I.3/2NP1	on request
Accessories for optimum fastening			
	Mounting system for rods \varnothing 12mm	BTU D18M-D12	50117490
	Mounting system <i>omni-mount</i>	BT318B-OM	50121904
	Mounting bracket for standard mounting	BT D18M.5	50113548
	Mounting bracket for <i>omni-mount</i>	BT D21M	50117257

Part number code

		F	T	3	2	8	I	.	3	/	4	P	-	M	1	2	P	1
Operating principle																		
FT	Reflection light scanner with fading																	
Series																		
328I	Series 328 with infrared light																	
Equipment																		
.3	Axial optics, teach-in via teach button																	
Switching output/function /OUT1/OUT2 (OUT1 = Pin 4, OUT2 = Pin 2)																		
4	PNP, light switching																	
P	PNP, dark switching																	
2	NPN, light switching																	
N	NPN, dark switching																	
Electrical connection																		
-M12	M12 connector, 4-pin																	
N/A	Cable, standard length 2m																	
Parameterization																		
P1	Configured for label detection																	

Setting the label sensor

The sensor evaluates the signal difference between a free glass surface (here: specular reflection) and a surface with a label (here: diffuse reflection). For optimum adaptation to the conditions, the sensor has two operating levels.

	Operating level 1: standard	Operating level 2: sensitive
Application (typical)	Clear signal difference between the free glass surface and the label surface, e.g., <i>paper label</i> .	Small signal difference between the free glass surface and the label surface, e.g., <i>foil label</i> .
Teach	Press button for 2 ... 7s until yellow LED flashes at 3Hz, then release button.	Press button for 7 ... 12s until LED flashes yellow and green alternately at 3Hz, then release button.
Observation	<p>After teaching, the sensor is in a stable OFF state and shows no faulty switching on the bare glass surface (without label). If the label is turned into the detection range of the sensor, the sensor detects the label over the entire length of the label.</p> <p>In the event of faulty switching on the glass surface, repeat the teach event. Check whether a stable switching behavior can be achieved with a slightly changed inclination.</p> <p>It may be necessary to change the teach mode from <i>Standard</i> to <i>Sensitive</i>.</p>	

- 1. Align the sensor on an area without label as shown:**
 Note the position of the teach button, the angle and the distance!

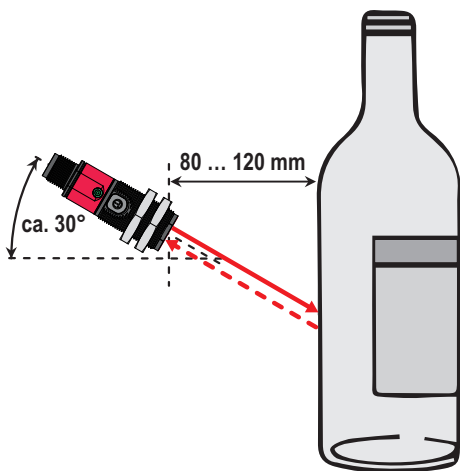

- 2. Teach the sensor:**
Standard (operating level 1)

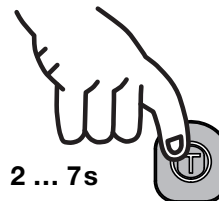

or

- Sensitive** (operating level 2)

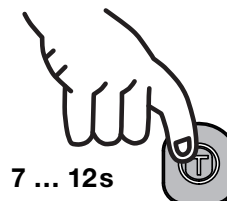

Fine adjustment of the switching threshold (sensitivity) using *easy tune*

The switching threshold can be adjusted upward and downward by pressing the teach button for a short or long period time. The effect is comparable to turning a potentiometer.

Press the teach button for a **short period of time** (2ms ... 200ms) to **increase the switching threshold**; the sensor becomes **less sensitive**.

Result: greater protection against faulty switching on the bare glass surface.
The required signal difference between glass and label surface is increased.
Used preferably with paper labels.

Press the teach button **for a long period of time** (200ms ... 2s) to **reduce the switching threshold**; the sensor becomes **more sensitive**.

Result: the required signal difference between glass and label surface is reduced.
Used preferably with foil labels.

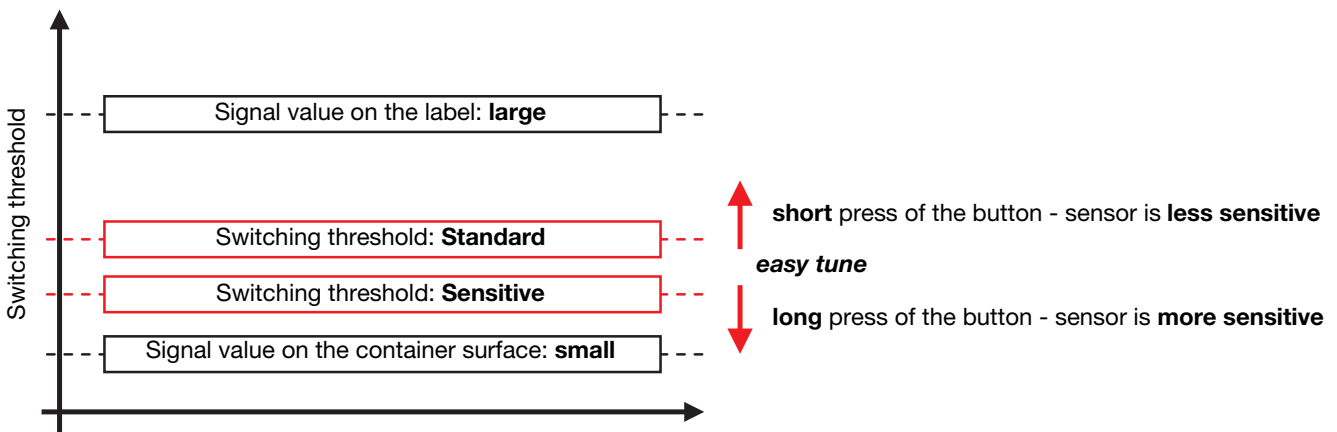

Remarks

The details on installation and on sensor setting take into account a typical application for detecting the label on a transparent container, e.g., mineral water in a glass or PET bottle with paper label. Having a particularly strong influence on the function are color and surface structure of the container, container contents, the geometrical arrangement of the sensor (angle to the horizontal as well as distance between sensor and container) and especially the label.

As long as there are clear signal differences between the bare container surface and the label surface, the sensor evaluates this and functions very robustly. A predominantly white paper label on a white PET milk bottle can, under some circumstances, not be detected due to the low signal difference. In the event of operating problems, we recommend always changing just one parameter and then observing the effect of the measure. Necessary changes could be:

1. **Standard** or **Sensitive** teach mode
2. Use ***easy tune*** to slightly increase or decrease the sensitivity.
3. Increase or decrease the angle to the horizontal
4. Increase or reduce the distance between sensor and container

Adjusting the switching behavior of the switching output – light/dark switching

This function permits inversion of the sensors' switching logic.

- Press teach button until the **green** LED flashes.
- Release teach button.
- The LED then displays the changed switching logic for 2s:

YELLOW
Cont. light = switching outputs **light switching**
 (in the case of complementary sensors, Q1 (pin 4) light switching, Q2 (pin 2) dark switching), this means output active when object is detected.

GREEN
Flash. light = switching outputs **dark switching**
 (in the case of complementary sensors, Q1 (pin 4) dark switching, Q2 (pin 2) light switching), this means output inactive when object is detected.

- Ready.

