

## Technical data sheet · DC UPS battery management system ECO

DC UPS battery management system ECO  
500 W



<b>Identification</b>	Type	L-COPS-B1-BME-500-24
	Part-No.	723002

### Use/Area of application

Battery test/monitoring is cyclic  
I-U<sub>0</sub>-U charge with car charge level  
temperature compensated charging voltage  
deep discharge protection (residual discharge current <300 µA)  
electronic battery short-circuit protection  
control by state-of-the-art digital technology  
signalling via LEDs, relays  
fault diagnosis (battery temperature, aging, cable break, etc.)  
Option: fast charge by means of power supply bypass

### General

Supported load circuit voltage power supply operation	DC 22 V – DC 30 V
Supported load circuit voltage battery operation	DC 18 V – DC 27 V
Deep discharge protection early warning	DC 21.6 V type
Deep discharge protection deactivation	Threshold DC 18 V type
Overload protection mains operation	External (current limit by means of DC power supply)
Overload protection buffer operation	locking electronic deactivation at $I_{out} > I_{nom} \times 1.75$
Reverse battery protection	Electronic isolation switch

14.08.2014 – Subject to technical modification

Part-No. 723002

USA: LUTZE INC.

13330 South Ridge Drive • Charlotte, NC 28273, USA  
Tel. +1 (704) 504-0222 • Fax +1 (704) 504-0223  
www.lutze.com • info@lutze.com

United Kingdom: LÜTZE Ltd.

Unit 3, Sandy Hill Park  
Sandy Way, Amington • GB-Tamworth, Staffs B77 4DU  
Tel. +44 (0)1827 31333-0 • Fax +44 (0)1827 31333-2  
www.lutze.com • sales.gb@lutze.co.uk



SYSTEMATIC TECHNOLOGY

## Technical data sheet - DC UPS battery management system ECO

Battery charge	Temperature is controlled (external sensor included) emergency operation if temperature sensor is not connected	
Battery charging current	max. DC 1.5 A option: fast charging by means of power supply bypass	
Buffer time limit	adjustable by potentiometer from 10 s to 600 s or infinite (deep discharge point)	
External battery	see accessories	
Battery types	all standard types of lead acid batteries	
Signalling		
Signalling	LED green	Mains operation / battery operation
	LED yellow	Charging
	LED red	Device or battery fault
	Relay 1	DC 30 V, DC 1 A, 1 NO contact, mains operation monitoring
	Relay 2	DC 30 V, DC 1 A, 1 NO contact, warning threshold monitoring
	Relay 3	DC 30 V, DC 1 A, 1 NO contact, composite error monitoring
Operation temperature range	-25 °C – 70 °C	
Cooling	Air convection	
Storage temperature range	-40 °C – 85 °C	
Humidity	100 %, condensation allowed (coated circuit boards)	
Own consumption	Buffer mode: 60 mA type	
Battery residual discharge current	<300 µA (deep discharge protection, battery disconnected from load)	
Electrical safety	EN 60950, SELV, protection class III	
Emitted interference	EN 55011 class B	
Interference immunity	EN 61000-6-2	
Protection class	IP 20	
Installation position	Horizontal on all mounting rails acc. EN 60715	
Connection cross-sections		
Connection cross-sections	Mains supply	Faston flat terminal plugs 6.3 × 0.8 mm
	Load, battery	Faston flat terminal plugs 6.3 × 0.8 mm
	Signal	Plug-in screw terminals 10-pin, 0.5 – 2.5 mm <sup>2</sup> , flexible, rigid, RM 3.81
Dimensions (w × h × d) in mm	39.0 × 139.0 × 130.0	
Weight (kg/piece)	0.500	

14.08.2014 – Subject to technical modification

Part-No. 723002

USA: LUTZE INC.

13330 South Ridge Drive • Charlotte, NC 28273, USA

Tel. +1 (704) 504-0222 • Fax +1 (704) 504-0223

www.lutze.com • info@lutze.com

United Kingdom: LÜTZE Ltd.

Unit 3, Sandy Hill Park

Sandy Way, Amington • GB-Tamworth, Staffs B77 4DU

Tel. +44 (0)1827 31333-0 • Fax +44 (0)1827 31333-2

www.lutze.com • sales.gb@lutze.co.uk



SYSTEMATIC TECHNOLOGY

**Dimensions**

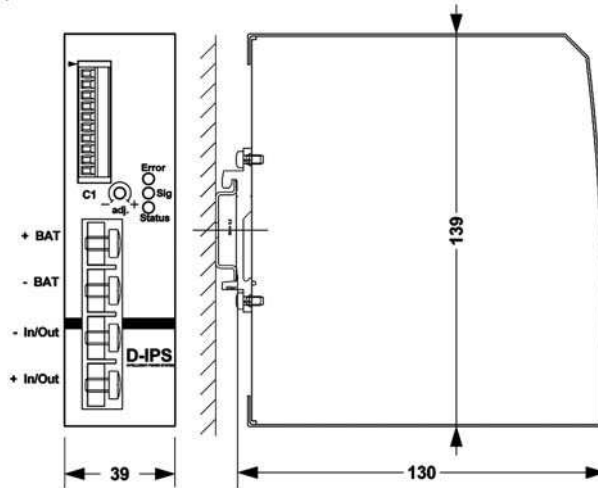

**Signal connection**

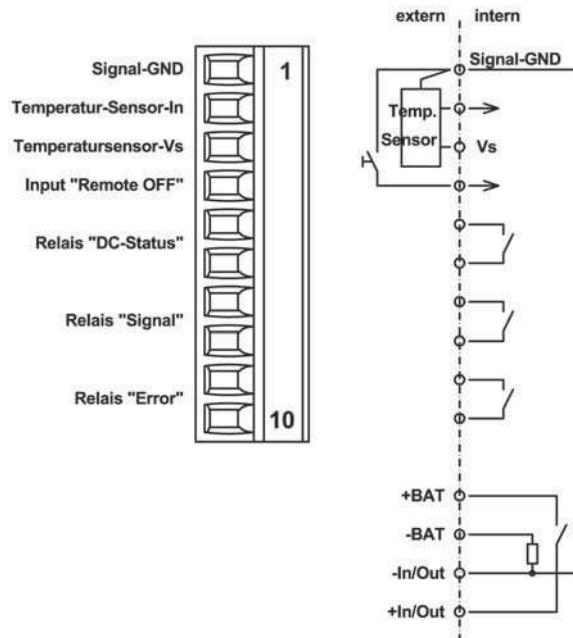

14.08.2014 – Subject to technical modification

Part-No. 723002

USA: LUTZE INC.

13330 South Ridge Drive · Charlotte, NC 28273, USA

Tel. +1 (704) 504-0222 · Fax +1 (704) 504-0223

www.lutze.com · info@lutze.com

United Kingdom: LÜTZE Ltd.

Unit 3, Sandy Hill Park

Sandy Way, Amington · GB-Tamworth, Staffs B77 4DU

Tel. +44 (0)1827 31333-0 · Fax +44 (0)1827 31333-2

www.lutze.com · sales.gb@lutze.co.uk



SYSTEMATIC TECHNOLOGY

## PIN assignment

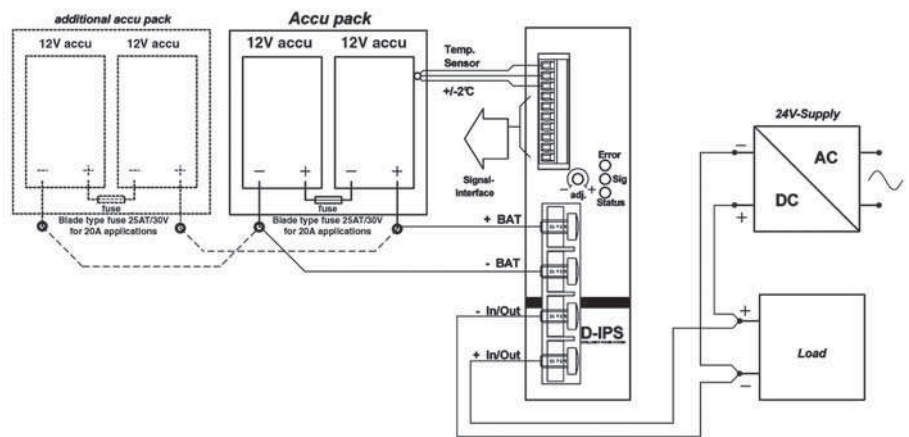

14.08.2014 – Subject to technical modification

Part-No. 723002

USA: LUTZE INC.

13330 South Ridge Drive • Charlotte, NC 28273, USA  
Tel. +1 (704) 504-0222 • Fax +1 (704) 504-0223  
www.lutze.com • info@lutze.com

United Kingdom: LÜTZE Ltd.

Unit 3, Sandy Hill Park  
Sandy Way, Amington • GB-Tamworth, Staffs B77 4DU  
Tel. +44 (0)1827 31333-0 • Fax +44 (0)1827 31333-2  
www.lutze.com • sales.gb@lutze.co.uk