



Identification	Type	RE 7 AC/DC 115V 1W RelGel
	Part-No.	762306
Input		
Input voltage range	92.0 V – 126.5 V	
Nominal voltage	AC/DC 115 V	
Rated frequency	50–60 Hz	
Rated current	4.0 mA	
Interrupting voltage	<2.4 V	
Protection device	Bridge rectifier	
Rated insulation voltage (EN 50178)	150 V	
Max. length of connecting lead	DC: 500 m AC: 40 m	
Status Indication	LED yellow	
Load Side		
Contact type	1 change over contact	
Min. switching voltage	AC/DC 17 V	
Max. switching voltage	AC/DC 250 V	
Min. switching current	AC/DC 5 mA	
Max. switching current	AC/DC 6 A	
Switching capacity AC 15	3 A	
Switching capacity DC 13	at 24 V: 1 A; at 115 V: 200 mA; at 230 V: 100 mA	
Max. switching capacity	1500 VA	

03.04.2016 – Subject to technical modification

Part-No. 762306

USA: LUTZE INC.

13330 South Ridge Drive • Charlotte, NC 28273, USA
Tel. +1 (704) 504-0222 • Fax +1 (704) 504-0223
www.lutze.com • info@lutze.com

United Kingdom: LUTZE Ltd.

Unit 3, Sandy Hill Park
Sandy Way, Amington • GB-Tamworth, Staffs B77 4DU
Tel. +44 (0)1827 31333-0 • Fax +44 (0)1827 31333-2
www.lutze.com • sales.gb@lutze.co.uk



SYSTEMATIC TECHNOLOGY

Technical data sheet · Interface Technology

Contact material	AgSnO ₂
Mechanical service life	> 5 x 10 ⁶ operations
Switch-on delay	8 ms
Switch-off delay	13 ms
Clearance/creep. dist. (control/load side)	>5.5 mm
Rated insulation voltage (EN 50178)	300 V

General

Housing material	PA 6.6 (UL 94 V-0)
Protection class	IP 20
Field installation	rail TS 35 (EN 50022)
Insulation voltage input/output	4.0 kV _{eff}
Safe isolation	yes
Operation temperature range	-25 °C – 60 °C
Storage temperature range	-40 °C – 80 °C
Dimensions (w × h × d)	6.2 × × 92.0 mm
Weight (kg/piece)	0.035
Termination	Spring terminal 0.5–1.5 mm ²

Dimensions

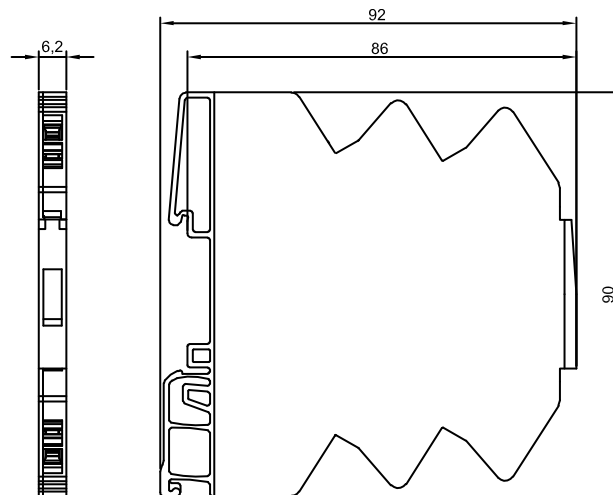

03.04.2016 – Subject to technical modification

Part-No. 762306

USA: LUTZE INC.

13330 South Ridge Drive · Charlotte, NC 28273, USA
Tel. +1 (704) 504-0222 · Fax +1 (704) 504-0223
www.lutze.com · info@lutze.com

United Kingdom: LUTZE Ltd.

Unit 3, Sandy Hill Park
Sandy Way, Amington · GB-Tamworth, Staffs B77 4DU
Tel. +44 (0)1827 31333-0 · Fax +44 (0)1827 31333-2
www.lutze.com · sales.gb@lutze.co.uk



SYSTEMATIC TECHNOLOGY

PIN assignment

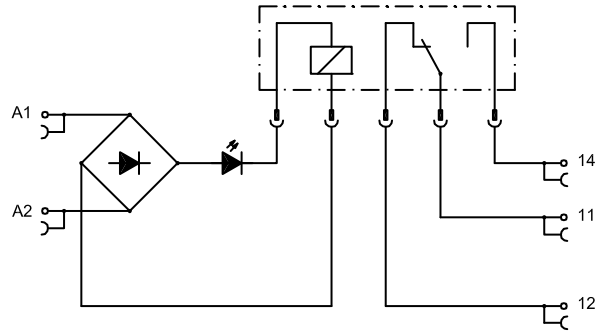

Limit curve

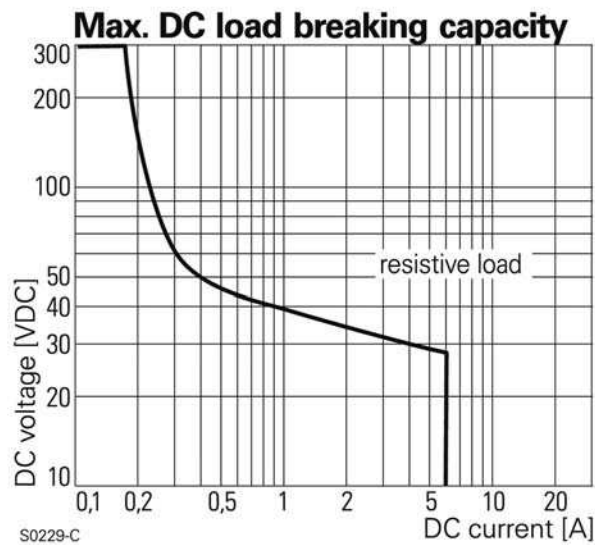

Accessories

Accessories	Color	Article number	Type	PU
Tag holder 4×11 mm	white	681313	BZT-0411	100
Isolation plate		760809	TP 7-0809	5

Accessories

Accessories	Color	2-pole	3-pole	4-pole	8-pole	16-pole	PU
6 A jumper comb	red	762802	762805	762812	762822	762832	10
6 A jumper comb	white	762803	762806	762813	762823	762833	10
6 A jumper comb	blue	762804	762807	762814	762824	762834	10

03.04.2016 – Subject to technical modification

Part-No. 762306

USA: LUTZE INC.

13330 South Ridge Drive • Charlotte, NC 28273, USA

Tel. +1 (704) 504-0222 • Fax +1 (704) 504-0223

www.lutze.com • info@lutze.com

United Kingdom: LUTZE Ltd.

Unit 3, Sandy Hill Park

Sandy Way, Amington • GB-Tamworth, Staffs B77 4DU

Tel. +44 (0)1827 31333-0 • Fax +44 (0)1827 31333-2

www.lutze.com • sales.gb@lutze.co.uk



SYSTEMATIC TECHNOLOGY

Technical data sheet · Interface Technology

Comments

For operation with rated voltage and 100% ED over 24h/day, a distance of = 10 mm must be complied with between the modules or to the neighboring switching components.

03.04.2016 – Subject to technical modification

Part-No. 762306

USA: LUTZE INC.

13330 South Ridge Drive · Charlotte, NC 28273, USA
Tel. +1 (704) 504-0222 · Fax +1 (704) 504-0223
www.lutze.com · info@lutze.com

United Kingdom: LUTZE Ltd.

Unit 3, Sandy Hill Park
Sandy Way, Amington · GB-Tamworth, Staffs B77 4DU
Tel. +44 (0)1827 31333-0 · Fax +44 (0)1827 31333-2
www.lutze.com · sales.gb@lutze.co.uk