



Identification	Type	REI4-0461 4W HTV DC24V
	Part-No.	770461
Description	DC-Relay-Interface, 4 CO contact, pluggable AC/DC 250 V, 5 A, 1250 VA	
Input		
Rated voltage U_N	DC 24 V	
Input voltage range	19.2 – 26.4 V	
Rated current I_N	0.037 A	
Interrupting voltage	<2.4 V	
Protection device	Free-wheeling diode	
Status display input	LED green	
Power consumption	0.9 W	
Output		
Contact type	4 changeover contacts	
Min. switching voltage	AC/DC 5 V	
Max. switching voltage	AC/DC 250 V	
Min. switching current	AgNi + 5 μ m HV: AC/DC 2 mA	
Max. switching current	AC/DC 5 A	
Switching capacity DC 13	1,8 A @ 24 V, 300 mA @ 115 V, 150 mA @ 230 V	

25.08.2017 – Subject to technical modification

Part-No. 770461

USA: LUTZE INC.

13330 South Ridge Drive • Charlotte, NC 28273, USA
Tel. +1 (704) 504-0222 • Fax +1 (704) 504-0223
www.lutze.com • info@lutze.com

United Kingdom: LÜTZE Ltd.

Unit 3, Sandy Hill Park
Sandy Way, Amington • GB-Tamworth, Staffs B77 4DU
Tel. +44 (0)1827 31333-0 • Fax +44 (0)1827 31333-2
www.lutze.com • sales.gb@lutze.co.uk



SYSTEMATIC TECHNOLOGY

Technical data sheet · Interface Technology

Switching capacity AC 15	2.5 A @ 24 V, 1.5 A @ 230 V
Max. switching capacity	1250 VA
Contact material	AgNi + 5 µm HV
Mechanical service life	> 2 x 10 ⁷ operations
Switch-on delay	25 ms
Shutdown delay	25 ms
Clearance/creep. dist. (control/load side)	Air clearance: >2 mm, creep clearance: >3 mm
Protection device	none
Rated insulation voltage (EN 50178)	AC 250 V (category C 250)

General

Housing material	PA 6.6 + GF V0 (UL)
Colour of the housing	black
Protection class	IP20
Mounting	DIN rail mountable TS35
Insulation voltage input / output	1.5 kV _{eff}
Safe isolation	yes
Operation temperature range	-40 °C ... +70 °C
Storage temperature range	-40 °C ... +85 °C
Dimensions (w × h × d)	27.2 × 75.0 × 82.0 mm (including mounting bracket)
Weight	0.097 kg/piece
Connection device	Screw terminal 0.20 mm ² – 4.0 mm ²
Standards	EN 60947-4-1
Approvals	cULus

Comments

To prevent damage to the gold layer, the stated values should not be exceeded.
At higher switching capacity, the gold layer vaporizes. The undercurrent in the housing can result in flashovers between coil - contact.

25.08.2017 – Subject to technical modification

Part-No. 770461

USA: LUTZE INC.

13330 South Ridge Drive · Charlotte, NC 28273, USA
Tel. +1 (704) 504-0222 · Fax +1 (704) 504-0223
www.lutze.com · info@lutze.com

United Kingdom: LÜTZE Ltd.

Unit 3, Sandy Hill Park
Sandy Way, Amington · GB-Tamworth, Staffs B77 4DU
Tel. +44 (0)1827 31333-0 · Fax +44 (0)1827 31333-2
www.lutze.com · sales.gb@lutze.co.uk



SYSTEMATIC TECHNOLOGY

Dimensions

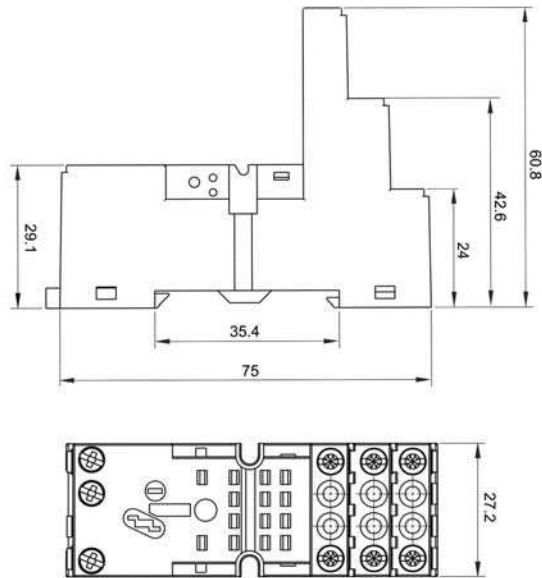

PIN assignment

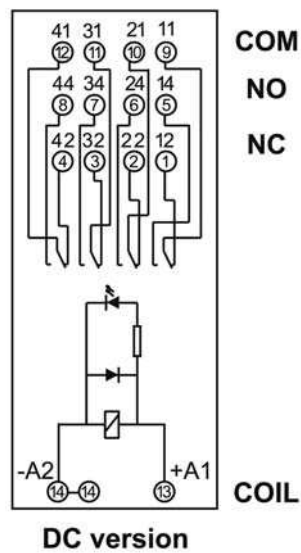

25.08.2017 – Subject to technical modification

Part-No. 770461

USA: LUTZE INC.

13330 South Ridge Drive • Charlotte, NC 28273, USA

Tel. +1 (704) 504-0222 • Fax +1 (704) 504-0223

www.lutze.com • info@lutze.com

United Kingdom: LÜTZE Ltd.

Unit 3, Sandy Hill Park

Sandy Way, Amington • GB-Tamworth, Staffs B77 4DU

Tel. +44 (0)1827 31333-0 • Fax +44 (0)1827 31333-2

www.lutze.com • sales.gb@lutze.co.uk



SYSTEMATIC TECHNOLOGY