



Powering Business Worldwide

Instruction Leaflet  
Montageanweisung  
Notice d'installation

02/89 AWA461-743

## L1-CI23

Devices, hole no. and size of the screws for the devices (M...x...);  
screwhead shape DIN 7985; spring washer DIN 137A  
Gerät, Loch-Nr. und Schraubengröße des Gerätes (M...x...); Kopfform DIN 7985;  
Federscheibe DIN 137A  
Appareils, no. des trous en taille des vis pour les appareils (M...x...); forme de tête DIN 7985;  
rondelle élastique DIN 137A

Typ

Typ	DILO(A)/M	Dd+Kdc	DIL1(A)/M	DIUL00(A)/M/11	DIULO(A)/M/11	TC-RMQ	3d+Kc	K10/1	K25/1	K50/1
	M4 x 16	M5 x 9	M5 x 16	M5 x 12	M5 x 12	M4 x 16	M5 x 9	M5 x 12	M5 x 12	M5 x 12
DILO(A)/M/I	9	10							15	
DIL1(A)/M/I		13	12						15	
DIULO(A)/M/11/I					1	3, 4, 5	6, 7, 8	14		
DIUL00(A)/M/11/I				1		3, 4, 5	6, 7, 8	14		
DIUL1M+P1DIL1M			2							15, 16
DIUL0M-G+P1DIL0M	9								15	

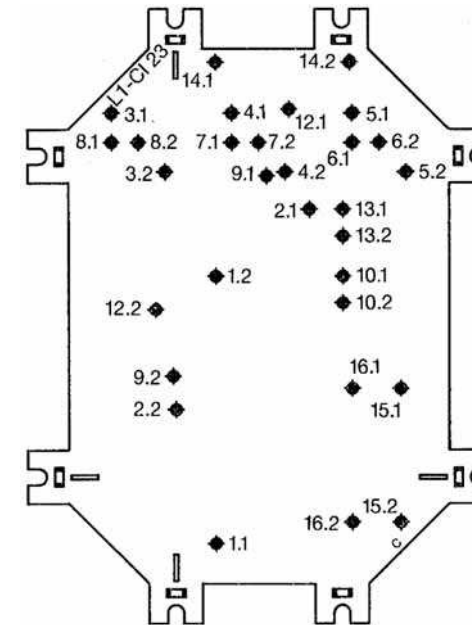

Kernlochdurchmesser für  
metrisches Gewinde DIN 13

M3-CI...

1

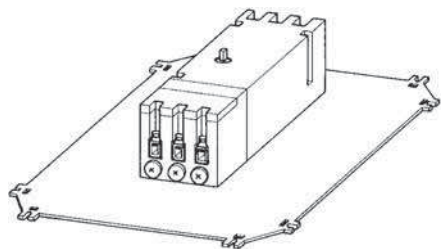

2

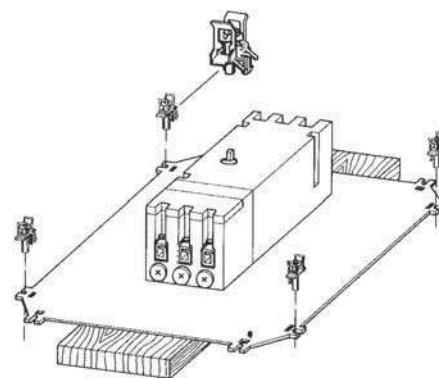

3

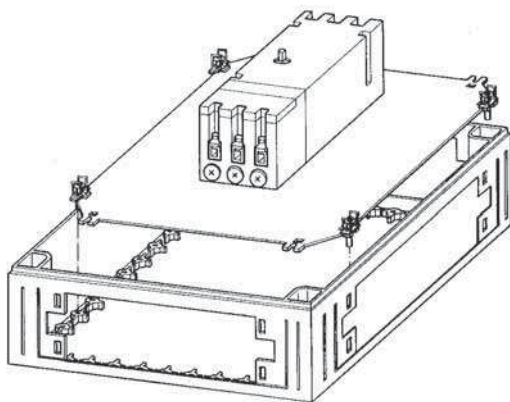

02/89 AWA461-743