

11/10 IL01206005Z  
(AWA1230-1917, AWA1230-2619)

**NZM2(-4)-160-XKC  
+NZM2(-4)-160-XKCO  
+NZM2(-4)-160-XKCU  
NZM2(-4)-250-XKC**

**+NZM2(-4)-250-XKCO  
+NZM2(-4)-250-XKCU  
NZM2(-4)-XKS**

...XKC Pressure Clamp Connector Kits for NZM2 Molded Case circuit-breakers and Switches

**-NA, -CNA**  
(UL/CSA models)

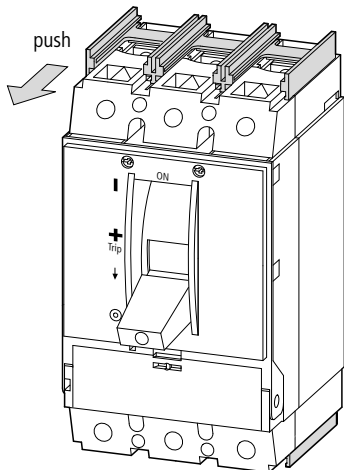

The barrier (shown shaded in the diagrams) is held tightly into grooves on top and bottom sides of the breaker or switch and must be removed in order to mount NZM2-XKC pressure clamp connectors.

To remove:

From the back of the device, use thumb pressure to push, or an appropriate tool to gently tap each side of the barrier to help slide it out.

**Note:**

Do not discard!

It will be necessary to re-install the barrier once the XKC connectors are mounted.

Refer to instructions and diagrams which follow.

(en) **Electric current! Danger to life!**

Only skilled or instructed persons may carry out the following operations.

(de) **Lebensgefahr durch elektrischen Strom!**

Nur Elektrofachkräfte und elektrotechnisch unterwiesene Personen dürfen die im Folgenden beschriebenen Arbeiten ausführen.

(fr) **Tension électrique dangereuse !**

Seules les personnes qualifiées et averties doivent exécuter les travaux ci-après.

(es) **¡Corriente eléctrica! ¡Peligro de muerte!**

El trabajo a continuación descrito debe ser realizado por personas cualificadas y advertidas.

(it) **Tensione elettrica: Pericolo di morte!**

Solo persone abilitate e qualificate possono eseguire le operazioni di seguito riportate.

(zh) **触电危险!**

只允许专业人员和受过专业训练的人员进行下列工作。

(ru) **Электрический ток! Опасно для жизни!**

Только специалисты или проинструктированные лица могут выполнять следующие операции.

(en) **Caution!**  
The removal or exchange of parts during mounting may become necessary. Refer to installation instructions for proper assembly and to maintain electrical clearances.

(de) **Vorsicht!**  
Für die Durchführung der beschriebenen Arbeiten kann das Entfernen oder der Austausch von Teilen notwendig sein. Bitte alle Installations-Anweisungen beachten, um die erforderlichen Luft- und Kriechstrecken nach dem Zusammenbau zu gewährleisten.

(fr) **Attention !**  
L'enlèvement ou l'échange de certaines pièces pendant le montage est parfois nécessaire. Consultez l'instruction d'assemblage pour assurer une installation conforme aux normes.

(es) **¡Atención!**  
Con el fin de llevar a cabo los trabajos descritos, puede ser necesario eliminar o cambiar alguna pieza. Le rogamos tenga en cuenta todas las instrucciones de instalación para así garantizar las líneas de fuga y efluvo necesarias tras el montaje.

(it) **Attenzione!**  
Per l'esecuzione degli interventi descritti potrebbe essere necessaria la rimozione o sostituzione di alcuni pezzi. Attenersi alle istruzioni d'installazione per garantire dopo l'assemblaggio le vie di dispersione necessarie.

(zh) **小心!**  
执行所描述的操作时可能需要拆除或更换零部件。请遵守所有相关的安装说明，以确保在组装后能获得需要的空间距离或爬电距离。

(ru) **Осторожно!**  
При проведении описанных процедур может возникнуть необходимость демонтировать или заменить детали. Для обеспечения надлежащих зазоров и вывода тока утечки, соблюдайте все инструкции по монтажу.

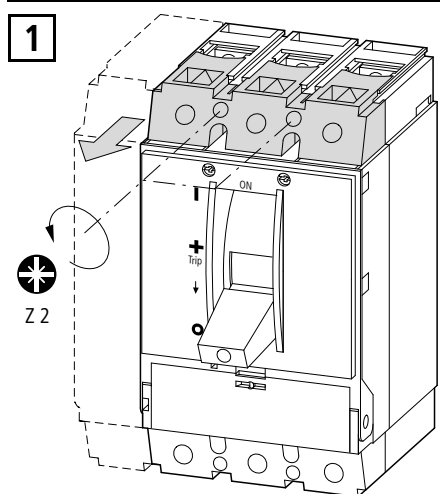

Removal of XKS Screw termination Connectors from NZM2.

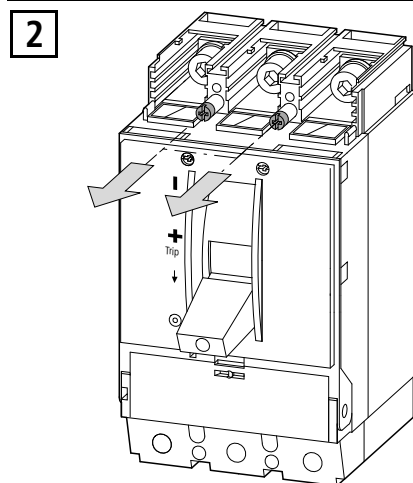

Removal of XKS Screw termination Connectors as shown in the diagrams will enable mounting of XKC pressure Clamp Connector kits.

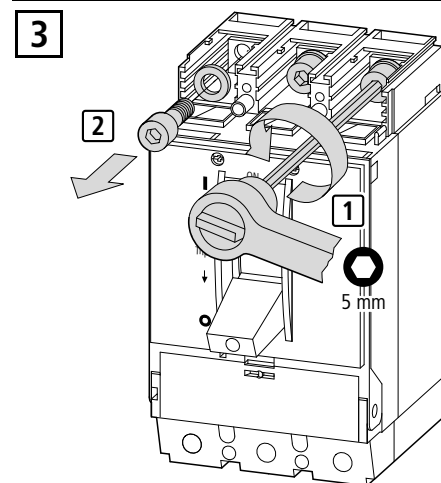

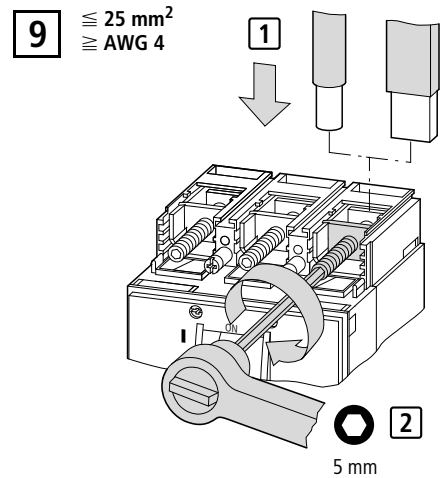
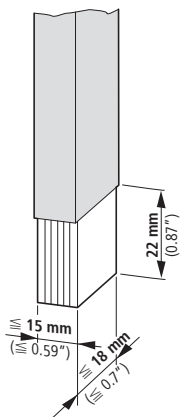
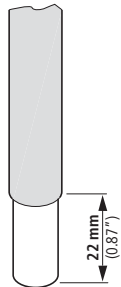
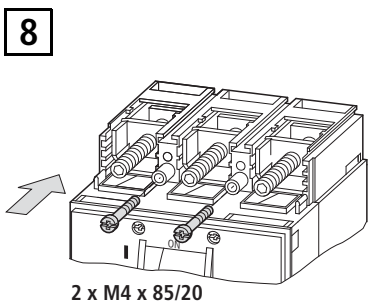
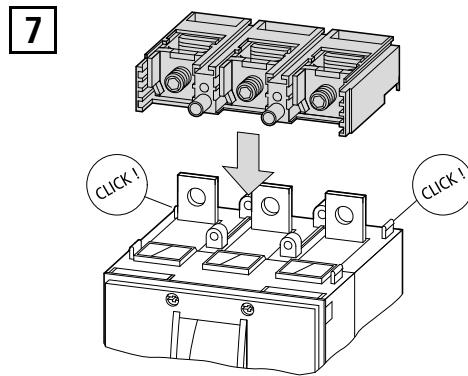
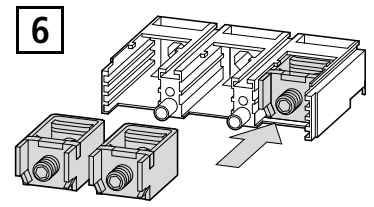
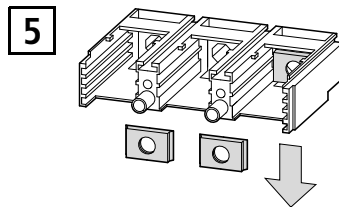
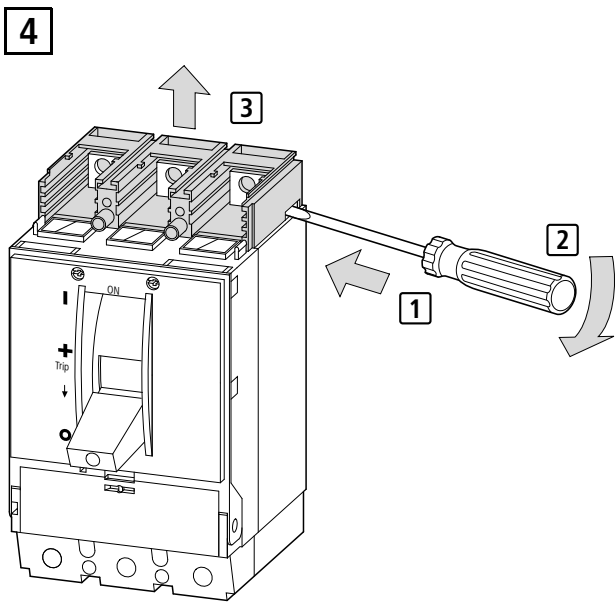

1 × 4 – 185 mm <sup>2</sup>	≅ 2 × 9 × 0.8 mm
2 × 4 – 70 mm <sup>2</sup>	
1 × AWG 12 – 350 kcmil	

UL/CSA = Cu only, Ampacity per 75° C Table.

Nm	lb-in
14	> 10 mm <sup>2</sup> , > AWG 8
5	≅ 10 mm <sup>2</sup> , ≅ AWG 8

10 ≅ 35 – 185 mm<sup>2</sup>  
≅ AWG 2 – 350 kcmil

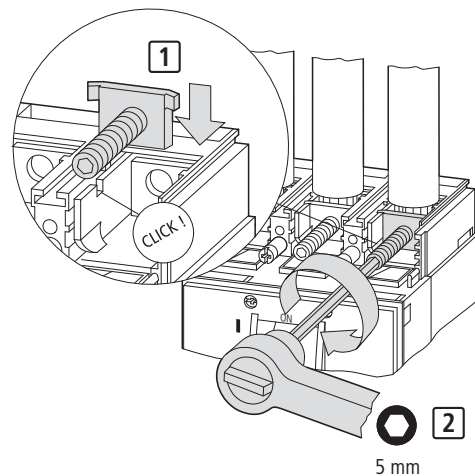
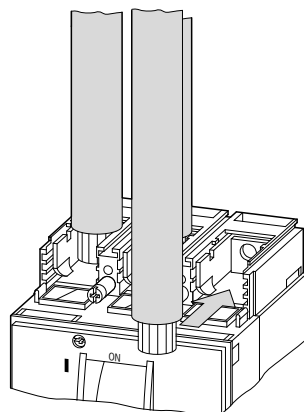
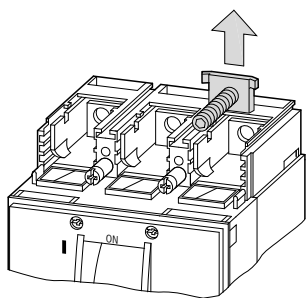

On larger cable cross-sections, clamp can be removed and re-inserted as shown to better facilitate wiring.

Nm	lb-in
14	> 10 mm <sup>2</sup>
123	> AWG 8

11/10 IL01206005Z

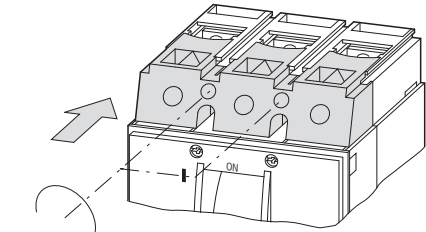
**11**

Z 2  
1.3 Nm (11.5 lb-in)

NZM2(-4)-XKS

**13a**

XKC → XKS

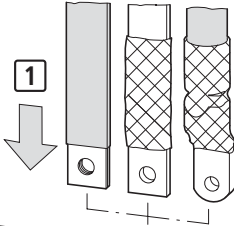
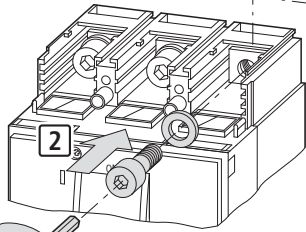
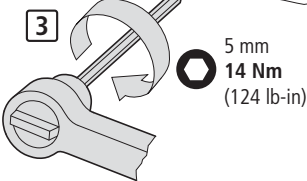
**1****2****3**

5 mm  
14 Nm  
(124 lb-in)

11/10 IL01206005Z

Removal of XKC Pressure clamp connectors to re-install XKS Screw terminations.

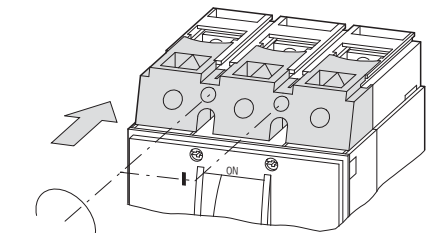
**13c**

Z 2  
1.3 Nm (11.5 lb-in)

**12**

-NA, -CNA  
(UL/CSA models)

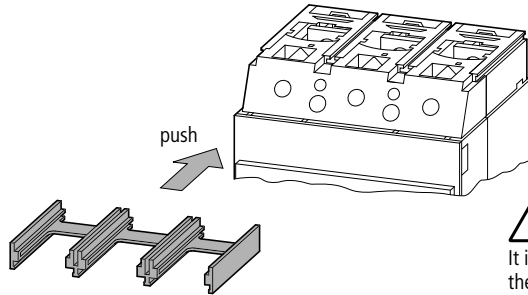

It is necessary to re-install the barrier to maintain proper electrical clearances!

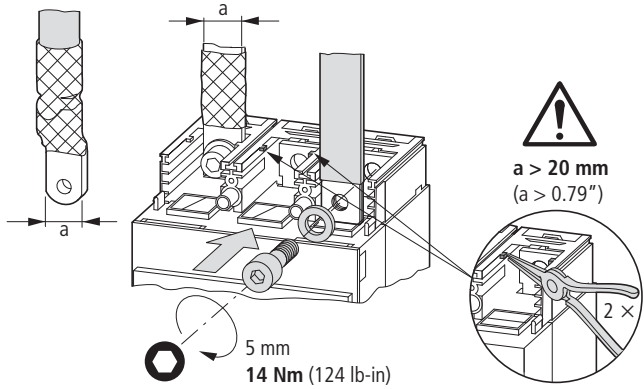
**13b**

$a > 20 \text{ mm}$   
( $a > 0.79''$ )

5 mm  
14 Nm (124 lb-in)

Removal of XKC pressure clamp connector kits will enable re-installation of XKS screw termination connectors. Follow diagrams in this instruction sheet in reverse order to remove the XKC pressure clamp connectors and proceed as shown above to re-install XKS screw terminations.

**13d**

-NA, -CNA  
(UL/CSA models)

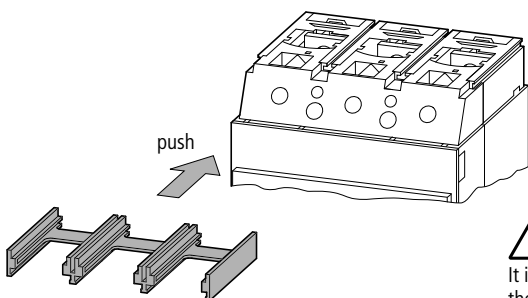

It is necessary to re-install the barrier to maintain proper electrical clearances!