

# Connection System SmartWire Modules

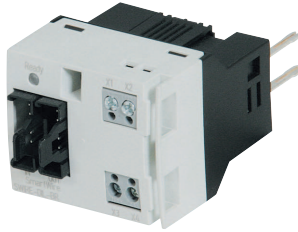

*Powering Business Worldwide*

All brand and product names are trademarks or registered trademarks of the owner concerned.

### **Emergency On Call Service**

Please call your local representative:

<http://www.eaton.com/moeller/aftersales>

or

Hotline of the After Sales Service:

+49 (0) 180 5 223822 (de, en)

[AfterSalesEGBonn@eaton.com](mailto:AfterSalesEGBonn@eaton.com)

### **Original Operating Instructions**

The German-language edition of this document is the original operating manual.

### **Translation of the original operating manual**

All editions of this document other than those in German language are translations of the original German manual.

1<sup>st</sup> published 2006, edition date 11/06,

2<sup>nd</sup> edition 04/08,

3<sup>rd</sup> edition 07/09,

See revision protocol in the "About this manual" chapter

© 2006 by Eaton Industries GmbH, 53105 Bonn

Production: Heidrun Riege

Translation: David Long

All rights reserved, including those of the translation.

No part of this manual may be reproduced in any form (printed, photocopy, microfilm or any other process) or processed, duplicated or distributed by means of electronic systems without written permission of Eaton Industries GmbH, Bonn.

Subject to alteration without notice.



# Danger!

## Dangerous electrical voltage!

---

### Before commencing the installation

- Disconnect the power supply of the device.
- Ensure that devices cannot be accidentally restarted.
- Verify isolation from the supply.
- Earth and short circuit.
- Cover or enclose neighbouring units that are live.
- Follow the engineering instructions (IL/AWA) of the device concerned.
- Only suitably qualified personnel in accordance with EN 50110-1/-2 (VDE 0105 Part 100) may work on this device/system.
- Before installation and before touching the device ensure that you are free of electrostatic charge.
- The functional earth (FE) must be connected to the protective earth (PE) or to the potential equalisation. The system installer is responsible for implementing this connection.
- Connecting cables and signal lines should be installed so that inductive or capacitive interference does not impair the automation functions.
- Install automation devices and related operating elements in such a way that they are well protected against unintentional operation.
- Suitable safety hardware and software measures should be implemented for the I/O interface so that a line or wire breakage on the signal side does not result in undefined states in the automation devices.
- Ensure a reliable electrical isolation of the low voltage for the 24 volt supply. Only use power supply units complying with IEC 60364-4-41 (VDE 0100 Part 410) or HD 384.4.41 S2.
- Deviations of the mains voltage from the rated value must not exceed the tolerance limits given in the specifications, otherwise this may cause malfunction and dangerous operation.
- Emergency stop devices complying with IEC/EN 60204-1 must be effective in all operating modes of the automation devices. Unlatching the emergency-stop devices must not cause restart.
- Devices that are designed for mounting in housings or control cabinets must only be operated and controlled after they have been installed with the housing closed. Desktop or portable units must only be operated and controlled in enclosed housings.

- Measures should be taken to ensure the proper restart of programs interrupted after a voltage dip or failure. This should not cause dangerous operating states even for a short time. If necessary, emergency-stop devices should be implemented.
- Wherever faults in the automation system may cause damage to persons or property, external measures must be implemented to ensure a safe operating state in the event of a fault or malfunction (for example, by means of separate limit switches, mechanical interlocks etc.).

# Contents

	<b>About this manual</b>	<b>3</b>
	List of revisions	3
	System Concept	3
	Intended users	4
	Reading conventions	4
<hr/>		
<b>1</b>	<b>Overview SmartWire System</b>	<b>7</b>
	Design	7
	SmartWire module for DILM	10
	SmartWire-I/O module	12
	SmartWire power module	13
	SmartWire connection cable	14
	SmartWire End Plug	16
<hr/>		
<b>2</b>	<b>Engineering</b>	<b>17</b>
	Combination with Eaton Switchgear	17
	– SmartWire module for DILM	17
	– SmartWire-I/O module	18
	Engineering Notes, System SmartWire	20
	– Data Transfer	20
	– SmartWire power section	21
<hr/>		
<b>3</b>	<b>Installation</b>	<b>23</b>
	Mechanical Mounting/Removal	23
	Electrical Installation	26
	– SmartWire power module	27
	– SmartWire module for DILM	28
	– SmartWire-I/O module	35
	– SmartWire terminal plug	36
	– Potential Relationship between the Components	37

Electromagnetic Compatibility (EMC)	38
– Earthing of inactive parts	38
– PE connection	39
– Earth-free Operation	39
– Mounting rails	39
System SmartWire for Safety Relevant Applications	40
– Feedback circuit	43
– Measures to achieve a higher safety category	43
System SmartWire for Applications in North America	46
– DOL starters	46
– Reversing starters	46
<hr/>	
<b>4 Commissioning</b>	<b>47</b>
<hr/>	
<b>5 Diagnostics and fault signals</b>	<b>49</b>
LED Diagnostic Signals	49
Exchange of Modules	52
– SmartWire module for DILM	52
– Motor starter or contactor	52
Fault-finding	53
<hr/>	
<b>Appendix</b>	<b>57</b>
Technical data	57
– General	57
– Environmental conditions	58
– Electromagnetic compatibility	59
– Supply voltage	60
– LED	61
– Connectionn potential-free contacts	61
– Relay outputs	62
– SmartWire modules	63
<hr/>	
<b>Index</b>	<b>65</b>

## About this manual

**List of revisions** The following significant amendments have been introduced since previous issues.

<b>Edition date</b>	<b>Page</b>	<b>Key word</b>	<b>New</b>	<b>Modification</b>	<b>Deleted</b>
07/09	Imprint	Emergency On Call Service		✓	
	9	fig. 1 „Assembly, connection system SmartWire“		✓	
	23	section “Mechanical Mounting/ Removal”		✓	
	26	fig. 9 „Schematic assembly of system SmartWire“		✓	
	35	section “SmartWire-I/O module”		✓	
04/08	23	„Mounting SmartWire I/O module and SmartWire power module“		✓	
	62	„Conventional free air thermal current I <sub>th</sub> “		✓	

**System Concept** The main part of a control system for a machine is these days carried out by a PLC. Typically the PLC is mounted in a control panel at a central position of the system. The control of the switchgear is carried out via special cables from the input and output terminals of the PLC for the control and return signals. With a decentral assembly the connections between the switchgear and the remote input/output system are of a similar type.

The system SmartWire is used for the connection between the switchgear and the PLC. The inputs/outputs of the PLC are relocated to the switchgear and connected by a plug-in cable. The switchgear is supplied, as much as possible, by the connection cable. This saves time with control wiring, saves space in the control panel because cable trunking is no longer necessary and reduces the necessary inputs/outputs on the PLC.

---

**Intended users** This manual is for the use of qualified personnel that design, install, commission and maintain system SmartWire.

---

**Reading conventions** Symbols used in this manual have the following meanings:

I/O	Input/Output
LED	Light-emitting diode
EMC	Electromagnetic compatibility
PLC	Programmable logic controller

► indicates actions to be taken.



**Caution!**

Warns of the risk of material damage.

**Warning!**

Warns of the possibility of serious damage and slight injury.

**Danger!**

Indicates the risk of major damage to property, or serious or fatal injury.



Draws your attention to interesting tips and supplementary information.

For greater clarity, the name of the current chapter is shown in the header of the left-hand page and the name of the current section in the header of the right-hand page. This does not apply to pages at the start of a chapter and empty pages at the end of a chapter.



# 1 Overview SmartWire System

---

## Design

The connection system SmartWire consists of the following components:

- SmartWire module for DILM,
- SmartWire I/O module,
- SmartWire power module,
- Gateways,
- SmartWire terminal plug,
- SmartWire connection cable.

The SmartWire system connects the switching device with the PLC.

SmartWire modules for DILM are mounted directly on relays, contactors or the contactors of the motor starters.

The SmartWire module for DILM takes over the functions of several inputs/outputs. A SmartWire connection cable connects the SmartWire modules for DILM to a gateway. The gateway then connects the system SmartWire with the superimposed field bus and therefore allows the communication to various field bus systems.

The respective gateways for the fieldbus systems are described in separate manuals.

- PROFIBUS-DP: SWIRE-GW-DP  
MN03407001Z-EN (previously AWB1251-1590GB)
- easyNET and CANopen: EASY223-SWIRE  
MN05006003Z-EN (previously AWB2528+1251-1589GB)
- I/O system XI/ON manual, supplier, company  
MicroInnovation AG, [www.microinnovation.com](http://www.microinnovation.com),  
Switzerland

The manuals are available for download on the Internet as PDF files. They can be quickly located at <http://www.moeller.net/en/support/index.jsp> by entering the document number as the search term.

The plug-in SmartWire connection cables between the individual switchgear and to the gateway provide the communication in the SmartWire system and the control voltage supply for the contactors.

The assembly of connection system SmartWire → fig. 1, page 9.

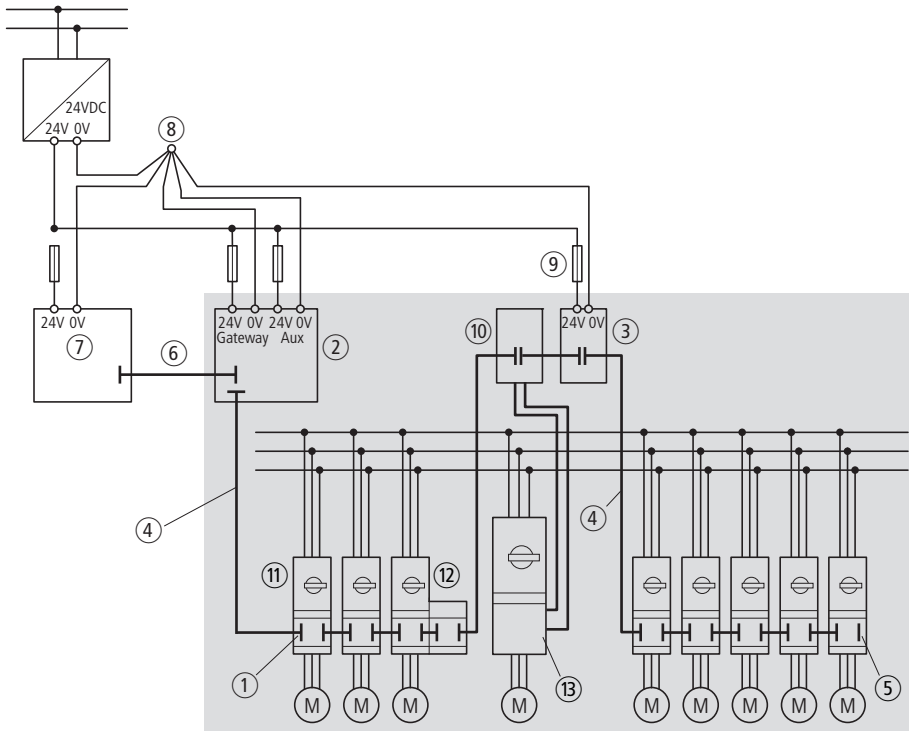

Figure 1: Assembly, connection system SmartWire

■ System SmartWire

- ① SmartWire Module for DILM: SWIRE-DIL
- ② Gateway
- ③ SmartWire power module: SWIRE-PF
- ④ SmartWire connection cable: SWIRE-CAB-...
- ⑤ SmartWire termination connector: SWIRE-CAB-000
- ⑥ Fieldbus
- ⑦ Programmable logic controller
- ⑧ Earth
- ⑨ Fuse
- ⑩ SmartWire I/O module: SWIRE-4DI-2DO-R
- ⑪ DOL starter MSC-D up to 32 A
- ⑫ Reversing starter MSC-R up to 32 A
- ⑬ DOL starter > 32 A (e.g. PKZM4 + DILM40)

**SmartWire module for DILM**

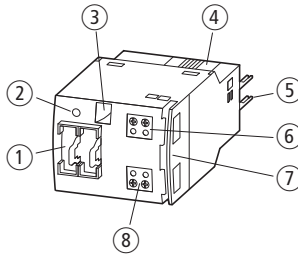

Figure 2: Layout of SmartWire module for DILM

- ① IN and OUT sockets for the connection cable
- ② Green LED
- ③ Mechanical switching position indicator
- ④ Catch slider
- ⑤ Connection pins
- ⑥ Connection terminals X1-X2
- ⑦ Cableway
- ⑧ Connection terminals X3-X4

The SmartWire module for DILM is fixed directly onto a DILM7 to DILM32 contactor, a DILA relay or an MSC motor starter.



**Caution!**

No extra auxiliary contact block can be fixed onto the contactor. The auxiliary contacts integrated in the contactor can be used, e.g. for safety interlocks.

The SmartWire module for DILM allows a contactor or a motor starter to be directly controlled from a PLC and the return signals to be monitored. The 6 pole SmartWire connection cable is connected via the IN and OUT ① sockets. The incoming cable into the socket IN, and the continuation cable to the next switching device with a SmartWire module from socket OUT.



An entire SmartWire line may contain a maximum of 16 SmartWire modules for DILM.

A green LED ② shows the status of the communication in the System SmartWire (→ section “LED Diagnostic Signals”, page 49).

As well as the communication signals a 24 V supply for the contactor coil is also transmitted via the SmartWire connection cable. The integrated electronics transfers the voltage to the connection pins ⑤ that are connected to the contactor coils. The SmartWire module for DILM is connected with the contact bridge of the contactor with the catch slider ④. Furthermore a signal for the switching state of the contactor in the field bus is given and also a mechanical switching state indication of the contactor ③ on the SmartWire module for DILM.

## SmartWire-I/O module

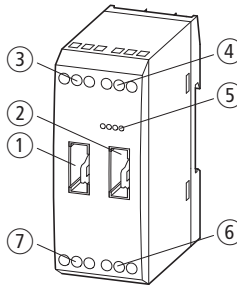

Figure 3: Layout of the SmartWire I/O module

- ① IN socket for SmartWire connection cable
- ② OUT socket for SmartWire connection cable
- ③ Terminals for relay output Q1
- ④ Terminals for Inputs I1 and I2
- ⑤ Green LEDs
- ⑥ Terminals for Inputs I3 and I4
- ⑦ Terminals for relay output Q2

The SmartWire I/O module provides digital inputs and outputs in the SmartWire system. Via the 4 inputs ④ and ⑥ different sensors can be integrated into the SmartWire system via potential-free contacts. Both digital relay outputs Q1 ③ and Q2 ⑦ can be used in the actuation of actuators up to a rated current of AC-15, 3 A at 250 V. The contactors DILM40 to DILH2000 can be integrated into the SmartWire system with the relay outputs. The power consumption of the contactor coils can be found in the main catalogue Industrial Switchgear, HPL0211, under Technical Data (→ [http://www.moeller.net/en/support/pdf\\_katalog](http://www.moeller.net/en/support/pdf_katalog)).

The status of the outputs and the SmartWire I/O module are signaled via green LEDs (→ section "LED Diagnostic Signals", page 49).



## SmartWire power module

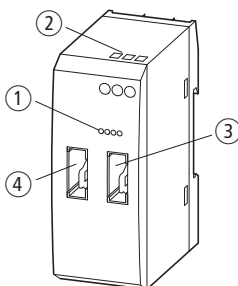

Figure 4: Layout of SmartWire power module

- ① Green Power Aux LEDs
- ② Connection terminals Aux
- ③ OUT socket for SmartWire connection cable
- ④ IN socket for SmartWire connection cable

The power module has two applications:

- Exceeding the power capacity of the contactors in the total SmartWire chain of 72 W/3 A,
- Requirement of selective safety switch-off of individual contactor groups or motor starter groups (→ section "System SmartWire for Safety Relevant Applications", page 40).

The connection cable is looped through the power module via interfaces ③ and ④. The power supply for the contactor coils is separated and connected to the connection terminals Aux ②.



### Caution!

With a SmartWire power module a second connection for the contactor coil control voltage can be made at another position in the SmartWire chain.

The green LED Power-Aux ① signals that the newly connected voltage of 24 V DC is available on the device (→ section "LED Diagnostic Signals", page 49).

---

**SmartWire connection cable**

The individual SmartWire modules are connected with the premanufactured, 6 pole, connection cable. The cable is fitted with plugs at both ends. Due to a mechanical keyway the plug can only be inserted in the correct position.

The incoming connection cable is connected to all modules in the socket IN and the continuation connection cable in the socket OUT.

The SmartWire connecting cables are available in 6 lengths:

- SWIRE-CAB-008: 8.5 cm,
- SWIRE-CAB-011: 11 cm,
- SWIRE-CAB-015: 15 cm,
- SWIRE-CAB-025: 25 cm,
- SWIRE-CAB-100: 100 cm,
- SWIRE-CAB-200: 200 cm.

The SWIRE-CAB-008 is intended for the connection of one SmartWire module for DILM to another. The SmartWire modules for DILM must be mounted on contactors of the same frame size directly adjacent to one another with a clearance = 0. This applies for both individual contactors and motor starters:

- DILM7 to DILM15 <-> DILM7 to DILM15
- DILM17 to DILM32 <-> DILM17 to DILM32

The SWIRE-CAB-011 connects a SmartWire module for DILM with the next when the contactors have different frame sizes or when they have the same frame size but the distance between the contactors  $\leq 18$  mm.

The SWIRE-CAB-015 is used for connection of the SmartWire modules for DILM to the motor starters of a different frame size. It connects the motor starter, which incorporates contactors DILM7 to DILM15 with starters in which contactors DILM17 to DILM32 are used.

The cable lengths of the connection between the gateway and the first SmartWire module for DILM or the SmartWire power module and a SmartWire module for DILM is dependent on the positioning of the gateway or the SmartWire power module:

- Mounting of gateway/power module beside the motor-protective circuit-breaker PKZM0: SWIRE-CAB-025,
- Mounting of gateway/power module beside the contactor DILM: SWIRE-CAB-015,
- Mounting of gateway beside the contactor DILM: SWIRE-CAB-025.



SWIRE-CAB-015 and SWIRE-CAB-025 can also be used when the cables SWIRE-CAB-008 and SWIRE-CAB-011 are too short for a special application.

The cable lengths of the connection between a SmartWire I/O module and a SmartWire module for DILM is dependent on the positioning of the SmartWire I/O module:

- Mounting of SmartWire I/O module beside the contactor: SWIRE-CAB-025,
- Mounting of SmartWire I/O module in the vicinity of the starter: SWIRE-CAB-100.

The SWIRE-CAB-100 and SWIRE-CAB-200 are used for bridging larger distances.

**Caution!**

The total cable length of the SmartWire line must not exceed a maximum of 400 cm.

---

**SmartWire End Plug**

The SmartWire termination connector SWIRE-CAB-000 is always plugged into the last SmartWire module for DILM of the entire SmartWire line in the OUT socket. This ensures the protection against contact with a finger on the SmartWire module for DILM is guaranteed.

## 2 Engineering

### Combination with Eaton Switchgear

#### SmartWire module for DILM

The Smartwire module for DILM can be combined with the contactors DILM7 to DILM32. Motor starters consisting of a PKZ and a DILM contactor can also be combined with the system SmartWire.

With contactor combinations a SmartWire module for DILM is required for each contactor.

Table 1: Combination possibilities

Application	Number of SmartWire modules for DILM
DILM contactor	1
Motor starter MSC	
DOL starter (PKZ and DILM)	1
Reversing starters	2
Reversing combination	2

As well as with contactors the SmartWire module for DILM can also be combined with all DILA relays.



Contactors  $\geq 32$  A can be integrated in the system SmartWire using a DILA as intermediate relay.

The contactor's power supply is directly supplied via the SmartWire connection cable. At 24 V DC the contactor coils have the following power consumption,  $\rightarrow$  table 2, page 18.

Table 2: Contactor coil power consumption

Contactor	Pick-up power [W]	Sealing power [W]
DILM7 - DILM9	3	3
DILM12 - DILM15	4.5	4.5
DILM17 - DILM32	12	0.5

**Caution!**

The sum of the pull-in power of the simultaneously operating contactors plus the total sealed power of the contactors per SmartWire chain must not exceed 72 W. When necessary an extra Power module must be used (→ section "SmartWire power module", page 13).

**SmartWire-I/O module**

Using the SmartWire I/O module further switchgear can be integrated into the SmartWire system.

The larger contactors DILM40 to DILH2000 are controlled using one of both relay outputs Q1 or Q2. They signal their state back to the SmartWire system using an auxiliary contact via outputs I1 to I4.

The integration of the soft starters DS4-M, DS4-MR and DS6-MX into the SmartWire system is implemented via the inputs I1 to I4 and the relay outputs Q1 and Q2.

Table 3: Inputs and outputs for soft starters

Soft starters	Output	Output	Input	Input
DS4-M	Start A1	–	Speed reached TOR	–
DS4-MR	Forward FWD	Backwards REV	Speed reached TOR	–
DS6-MX	Start A1	Enable EN	Speed reached TOR	Ready for operation

Circuit-breakers NZM, IZM and motor-protection circuit-breaker PKZ are also integrated. The following inputs I1 to I4 and relay outputs Q1 or Q2 are required.

Table 4: Inputs and outputs for circuit-breakers and motor-protection circuit-breakers

Motor-protective circuit-breaker, circuit-breaker	Output	Input
Standard auxiliary contacts	–	1
Trip-indicating auxiliary contact	–	1
Undervoltage release	1	–
Shunt releases	1	–
Remote operator	2	–
Residual current relay	–	1

Further control circuit devices, limit switches and further sensors can be integrated into the SmartWire system via a potential-free contact and inputs I1 to I4.

---

**Engineering Notes,  
System SmartWire**

In the system SmartWire it is differentiated between data transfer and the power supply of the SmartWire module for contactor control.

**Data Transfer**

A SmartWire line is limited to 16 slaves (SmartWire modules for DILM and SmartWire I/O modules). Any existing SmartWire power modules are not counted. The length of the line may not exceed a maximum of 400 cm. At the last SmartWire module the SmartWire system is terminated by a SmartWire termination connector. This termination connector is simply for protection against contact with a finger, it does not have an electrical function.

The write reaction time (switching command for the contactor) of the system SmartWire is fixed to 20 ms. The reading of the return signal is dependant upon the number of slaves (→ fig. 5).



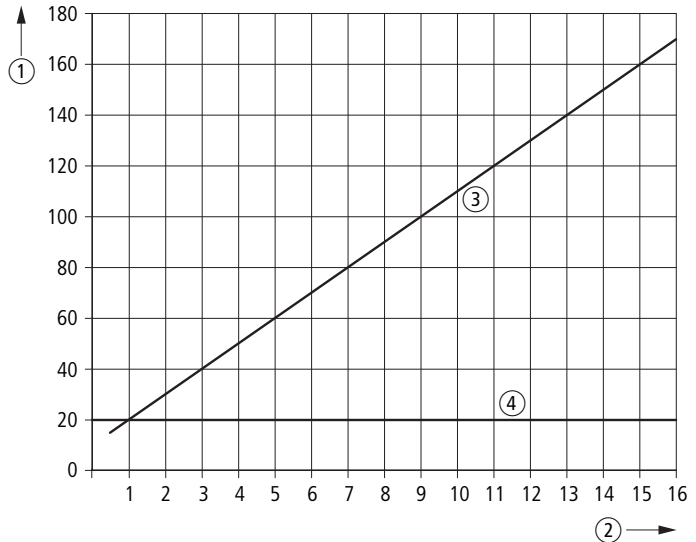

Figure 5: System SmartWire reaction times (worst case)

- ① Reaction time in ms
- ② Number of stations
- ③ Read
- ④ Write

If the switching state of the contactor does not change, the read time is reduced to about 60 % of the "worst case".

### SmartWire power section

The system SmartWire is supplied by a 24 V DC power supply. This supplies the gateway and also the contactor coils.

The gateway is protected by a 1 A gG/gL line protection fuse or a 1 A miniature circuit-breaker featuring characteristic C.

The fusing of the incoming supply for the contactor coils is implemented using 3 A gG/gL fuses or a 3 A miniature circuit-breaker featuring characteristic Z.



### 3 Installation

---

#### Mechanical Mounting/ Removal



The components of the SmartWire system are built-in devices. They must be installed in an enclosure, switch cabinet or distribution board with protection to IP54 or higher.



#### Caution!

To prevent additional heating of the I/O module keep a distance of  $> 5$  mm between the devices.

- ▶ Snap the the I/O module and the power module onto a 35 mm top-hat rail.

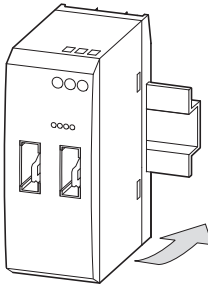

Figure 6: Mounting SmartWire I/O module and SmartWire power module



**Caution!**

The SmartWire module for DILM must only be mounted and demounted after the control voltage and power supply has been switched off.

- ▶ Set the setting slider on the SmartWire module for the corresponding contactor (→ fig. 7).
- Position **bottom**: DILA, DILM7, DILM9, DILM12 and DILM15
- Position **top**: DILM17, DILM25 and DILM32

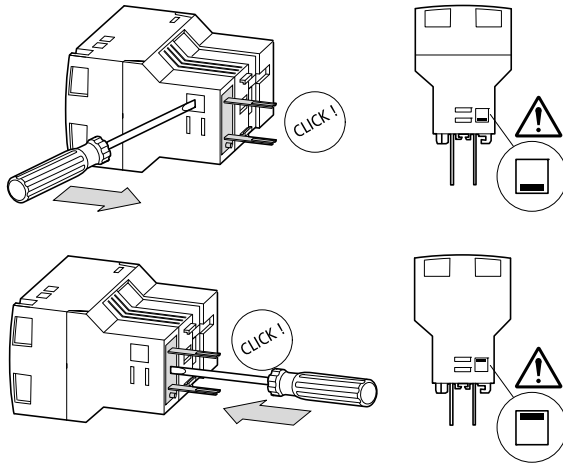

Figure 7: Assignment of SmartWire module for DILM and contactor

- ▶ Place the SmartWire module for DILM on the allocated contactor.
- ▶ Lock the SmartWire module for DILM.

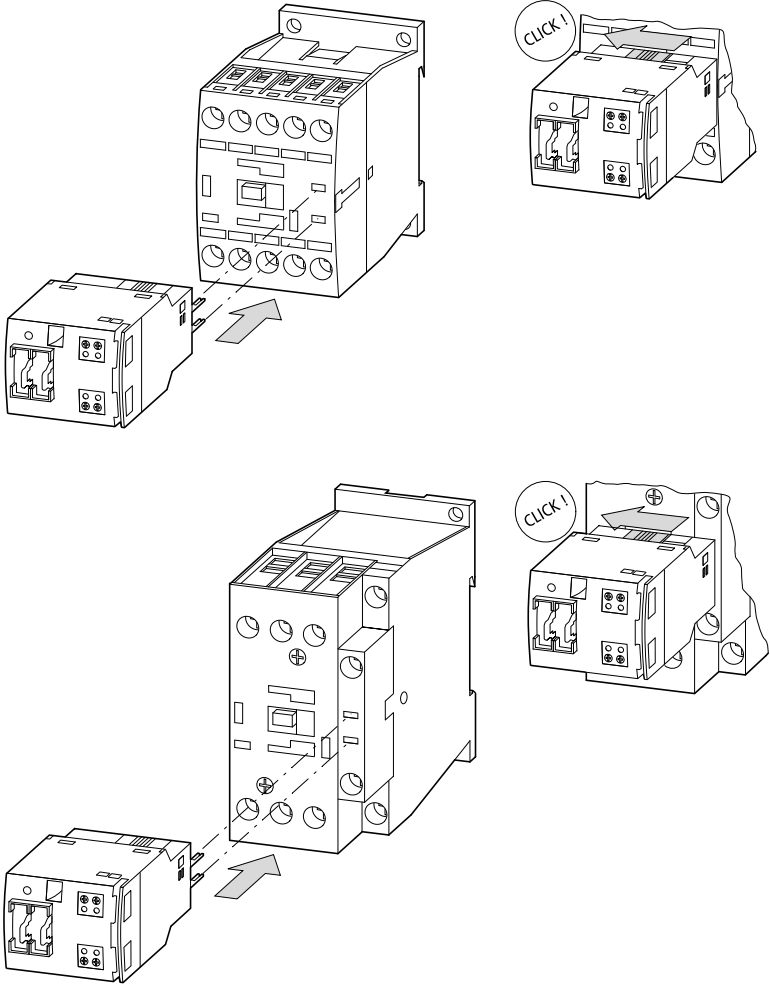

Figure 8: Mounting SmartWire module for DILM and contactor

Electrical Installation

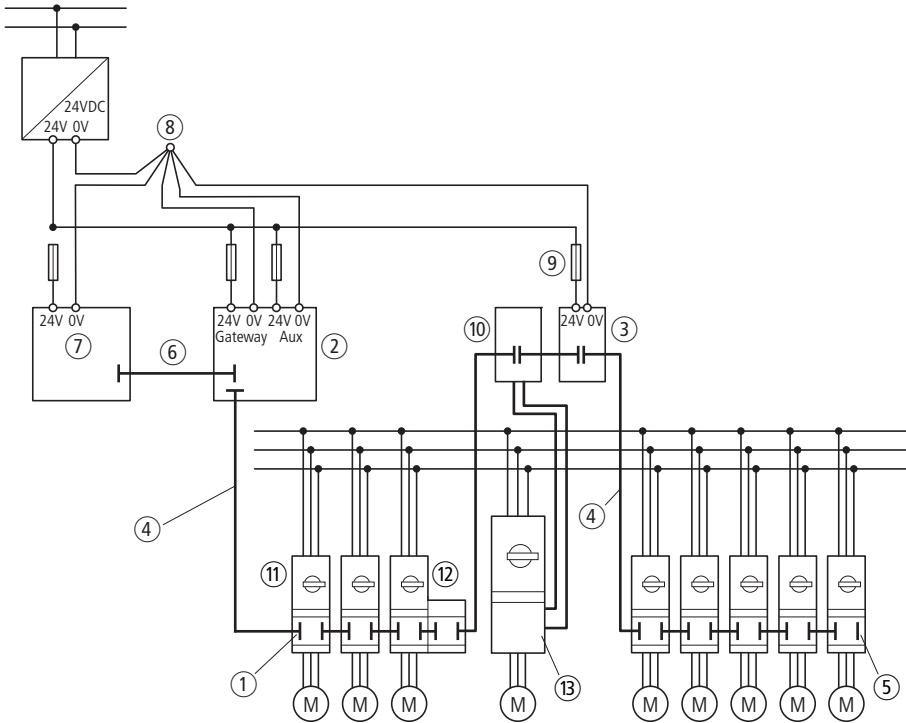

Figure 9: Schematic assembly of system SmartWire

- ① SmartWire module for DILM: SWIRE-DIL
- ② Gateway
- ③ SmartWire power module: SWIRE-PF
- ④ SmartWire connection cable: SWIRE-CAB-...
- ⑤ SmartWire termination connector: SWIRE-CAB-000
- ⑥ Fieldbus
- ⑦ Programmable logic controller
- ⑧ Earth
- ⑨ Fuse
- ⑩ SmartWire I/O module: SWIRE-4DI-2DO-R
- ⑪ DOL starter MSC-D up to 32 A
- ⑫ Reversing starter MSC-R up to 32 A
- ⑬ DOL starter > 32 A (e.g. PKZM4 + DILM40)



### Caution!

The different zero volt potentials of the gateway and the SmartWire power modules are wired to a common grounded star point.

### SmartWire power module

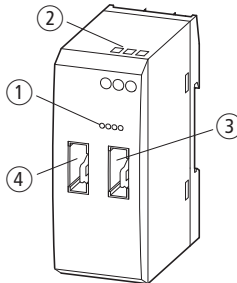

Figure 10: Connecting the SmartWire power module

- ① Green Power Aux LED
- ② Connection terminals Aux
- ③ Socket Out for SmartWire connection cable
- ④ Socket In for SmartWire connection cable

- ▶ Connect the 6-pole SmartWire connection cable to the IN socket ④. The continuation to the next SmartWire module for DILM is from the OUT ③ socket.
- ▶ Connect the 24 V DC control voltage for the contactor coils via the connection terminals Aux ② 24 V and 0 V.

The connection terminals are suitable for cables AWG22 to AWG16, and flexible cables with a cross section of 0.5 to 1.5 mm<sup>2</sup>. The terminals must be tightened with a torque of 0.6 Nm.

### SmartWire module for DILM

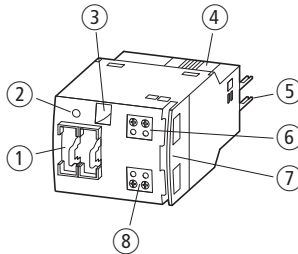

Figure 11: Connecting the SmartWire module for DILM

- ① Socket IN and OUT for connection cable
- ② Green LED
- ③ Mechanical switching position indicator
- ④ Catch slider
- ⑤ Connection pins
- ⑥ Connection terminals X1-X2
- ⑦ Cableway
- ⑧ Connection terminals X3-X4

### DOL Starter

The DOL starter is assembled from a PKZM0 and a contactor DILM7 to DILM32. The SmartWire module for DILM is mounted on the contactor. The SmartWire module for DILM is mounted on the contactor.

- Connect the 6 pole SmartWire connection cable via the IN and OUT ① sockets.

The incoming connection cable is inserted into the IN socket and the continuation to the next SmartWire unit inserted into the OUT socket.

The SmartWire module for DILM controls the contactor so the terminals A1-A2 must not be wired. Also a return signal will be given back to the system via the SmartWire module for DILM.



The terminals X3-X4 ⑧ are supplied with a bridging connection. If in the application electrical interlocking is required the bridge can be removed and the potential-free contacts connected.

**Danger!**

The terminals X3-X4 must not be used for safety relevant control devices (→ section "System SmartWire for Safety Relevant Applications", page 40).

A return signal to the PLC is available at terminals X1-X2 ⑥. When required, a potential-free auxiliary contact of the PKZ motor-protective circuit-breaker can be connected here.

**Caution!**

The cable to the potential-free auxiliary contacts from X1-X2 as well as from X3-X4 must have a maximum length of 2.8 m.

The cableway ⑦ is to accommodate further control wires to the PKZM0 or to the contactor auxiliary contacts.

The connection terminals on the SmartWire module are suitable for cables AWG22 to AWG16. and flexible cables with a cross section of 0.5 to 1.5 mm<sup>2</sup>. The terminals must be tightened with a torque of 0.5 Nm.

The auxiliary contacts integrated in the contactor can be used, e.g. for safety interlocks.

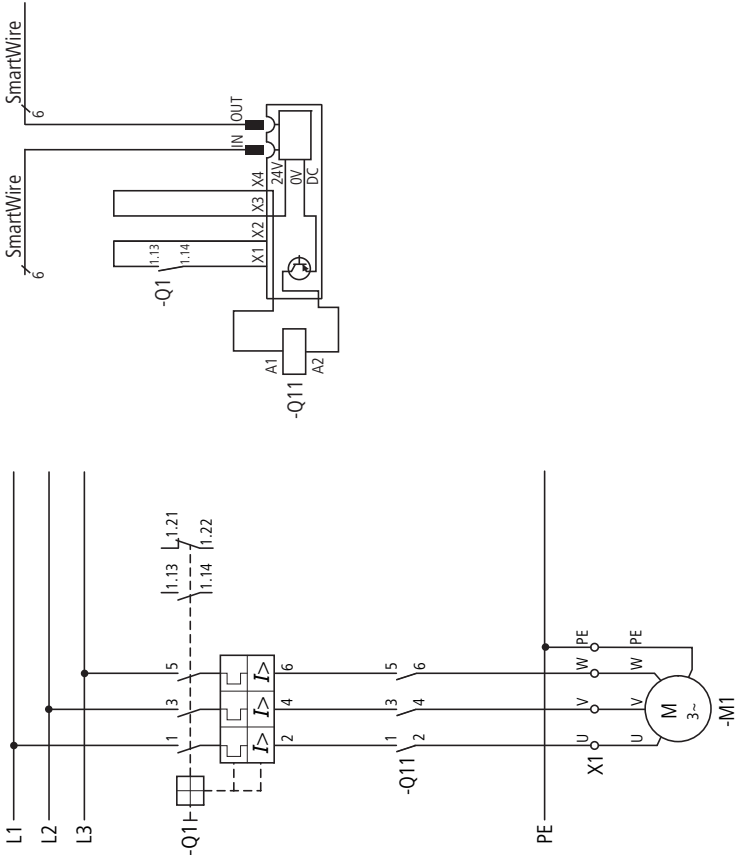

Figure 12: Circuit diagram DOL starter

### Reversing starter

The reversing starter is assembled from a PKZM0 and 2 contactors DILM7 - DILM32. A SmartWire module for DILM is mounted on each contactor.

- ▶ Connect the 6 pole SmartWire connection cable onto the SmartWire module for DILM via the IN and OUT ① sockets.

The incoming connection cable is inserted into the IN socket and the continuation to the second SmartWire unit inserted into the OUT socket.

This continuation is plugged into the IN socket of the second SmartWire module and from the OUT to the next SmartWire unit.

The SmartWire modules for DILM control the contactors so the terminals A1-A2 of the contactors need not be wired, with the exception of the DILM12-XEV bridge (→ fig. 13, page 33). Also a return signal to the system is given for each of the system SmartWire modules for DILM.

The terminals X3-X4 ⑧ are supplied with a bridging connection. For the electrical interlocking of both contactors this bridge is removed and the normally closed auxiliary contact (21-22) of the other contactor is connected as potential-free contact.



### **Danger!**

The terminals X3-X4 must not be used for safety relevant control devices (→ section "System SmartWire for Safety Relevant Applications", page 40).

A return signal input in the PLC is available at terminals X1-X2 ⑥. When required, a potential-free auxiliary contact of the PKZ motor-protective circuit-breaker can be connected here.



### **Caution!**

The cable to the potential-free auxiliary contacts from X1-X2 as well as from X3-X4 must have a maximum length of 2.8 m.

The cableway ⑦ is to accommodate further control wires to the PKZM0 or to the contactor auxiliary contacts.

The connection terminals on the SmartWire module are suitable for cables AWG22 to AWG16, and flexible cables with a cross section of 0.5 to 1.5 mm<sup>2</sup>. The terminals must be tightened with a torque of 0.5 Nm.

The auxiliary contacts integrated in the contactor can be used, e.g. for safety interlocks.



**Caution!**

The wiring sets DILM12-XRL and PKZM0-XRM12 must not be used for the assembly of the reversing starters.  
The A2 connection of the contactors must not be bridged.

The following jumpers can be used for wiring reversing starters.

Table 5: Jumpers for reversing starters

	DILM7 - DILM15	DILM17 - DILM32
L1, L2 and L3 parallel	DILM12-XP2	DILM32-XRL
Phase switch L1 and L3, L2 parallel	DILM12-XR	
Electrical interlock	DILM12-XEV	–

In combination with the jumpers DILM12-XEV the circuit → fig. 13 should be used. On the other hand, an electrical interlock with wire jumpers should be implemented according to the circuit → fig. 14, page 34.

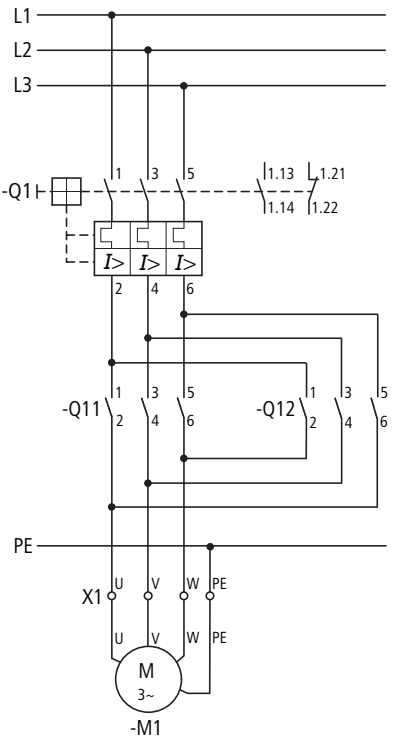
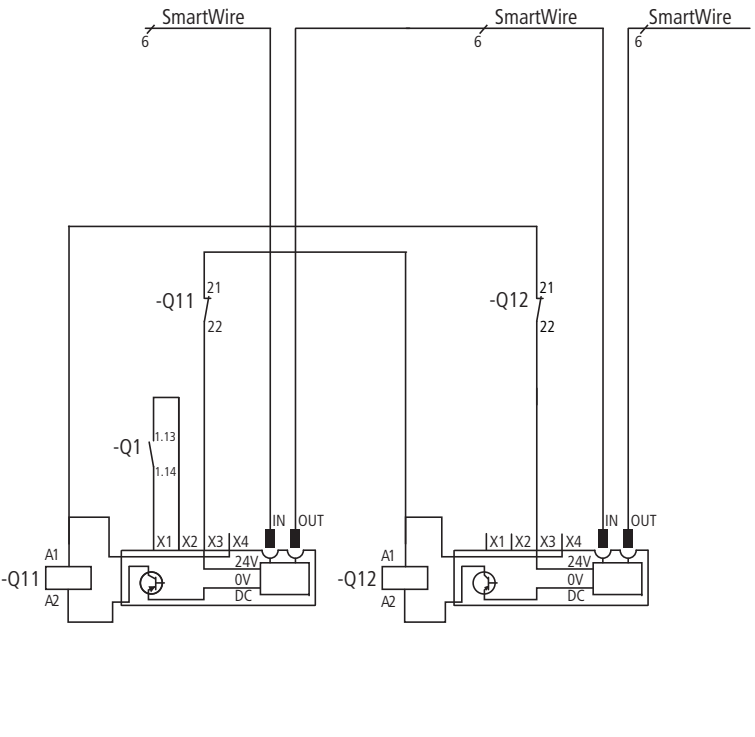

Figure 13: Reversing starter circuit diagram in conjunction with DILM12-XEV

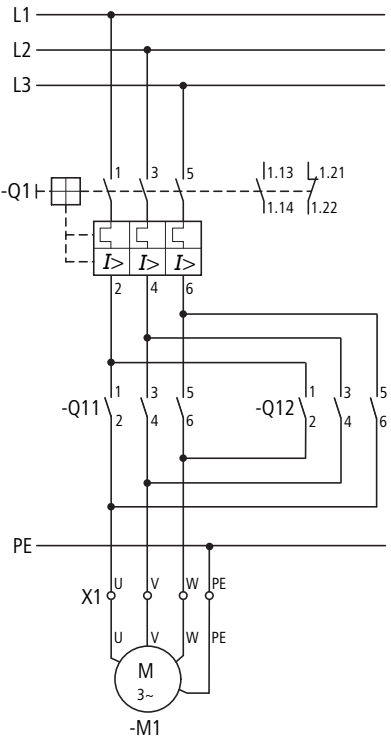
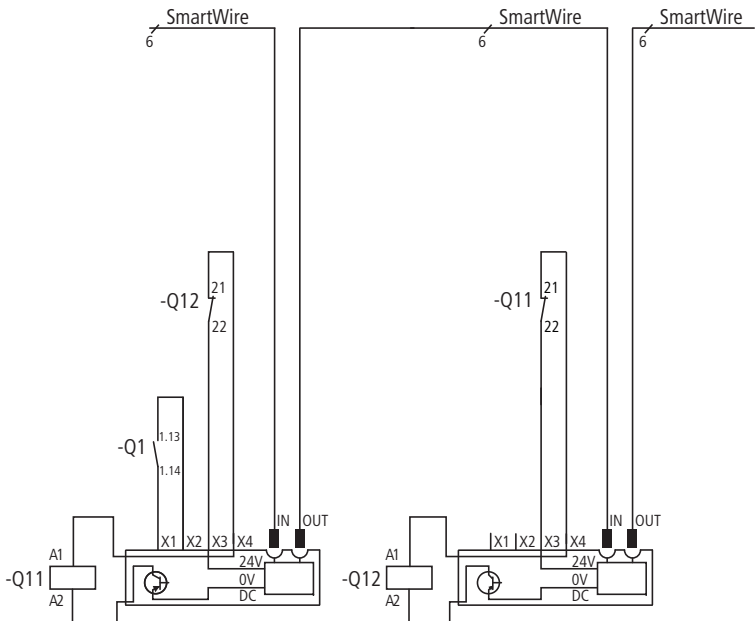

Figure 14: Circuit diagram reversing starter

### SmartWire-I/O module

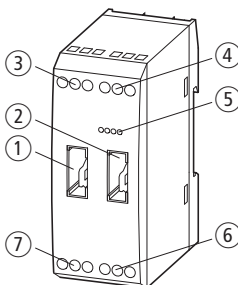

Figure 15: Layout of the SmartWire I/O module

- ① Socket In for SmartWire connection cable
- ② Socket Out for SmartWire connection cable
- ③ Terminals for relay output Q1
- ④ Terminals for inputs I3 and I4, U+
- ⑤ Green LEDs
- ⑥ Terminals for Inputs I3 and I4, U+
- ⑦ Terminals for relay output Q2

- ▶ Connect the 6 pole SmartWire connection cable via the IN ① and OUT ② sockets.

The incoming connection cable is inserted into the IN socket and the continuation to the next SmartWire unit inserted into the OUT socket.

The SmartWire I/O module provides 2 relay outputs Q1 ③ and Q2 ⑥.

- ▶ Wire the first relay output to Q1 and the second to Q2.



#### Caution!

The relay outputs Q1 and Q2 can be loaded up to a rated current at AC-15 of 3 A at 250 V.

Up to 4 potential-free contacts of sensors can be integrated into the SmartWire system.

- ▶ Connect the potential free contacts each between U+ and the corresponding input I1 to I4 ④ and ⑥.

The connection terminals on the SmartWire module are suitable for cables AWG22 to AWG16, and flexible cables with a cross section of 0.5 to 1.5 mm<sup>2</sup>. The terminals must be tightened with a torque of 0.6 Nm.

**Caution!**

The length of the cable to the 4 potential-free contacts must not exceed 2.8 m.

**SmartWire terminal plug**

- ▶ Plug the end plug into the OUT socket of the last SmartWire module for DILM of the SmartWire rung.



The end plug is only for the finger safety on the SmartWire units.



### Potential Relationship between the Components

The total system SmartWire operates with a common earth for the various voltages. This is supported externally by the wiring from a common star-point (→ section "Electrical Installation", page 26). Therefore the various supply voltages in the system SmartWire are not galvanically separated.



The potential relationships between the fieldbus and SmartWire system can be found in the corresponding manuals about gateway → section "Overview SmartWire System", page 7.

---

**Electromagnetic  
Compatibility (EMC)**

The system SmartWire conforms to requirements of the EMC guidelines. However an EMC planning is necessary before installation. All potential interference sources, such as galvanic, inductive and capacitive coupling as well as radiation coupling should be considered.

The EMC of the system SmartWire is ensured when the following rules are observed.

- Correct earthing of the inactive metal parts.
- Correct layout of wires and cables.
- Creation of a uniform reference potential and earthing of all electrical equipment.
- Special EMC measures for special applications.

**Earthing of inactive parts**

All inactive parts (e.g. switch panels, panel doors, support rails, mounting plates, top-hat rails, etc.) must be thoroughly and with low impedance connected to each other (earthing). Therefore a uniform reference potential for all control elements is ensured. The influence of coupled interference is decreased.

- With painted, anodised or insulated metal parts the insulating layer must be removed in the screw connection area. The connection point must be protected against corrosion.
- Moving earthed parts (panel doors, separate mounting plates, etc.) must be connected with short earthing strips with a large surface area.
- The use of aluminium should be avoided where possible as aluminium oxidises and is then not suitable for earthing.

**Danger!**

The earth must never – not even under fault conditions – have a dangerous touch voltage. Therefore the earth must be connected to the protective conductor.

**PE connection**

The earth and the PE (protective earth) connection must be centrally connected to each other.

**Earth-free Operation**

With earth-free operation the relevant safety standards must be observed.

**Mounting rails**

All mounting rails must be fixed with low impedance to the mounting plate and correctly earthed. The use of corrosion protected mounting rails is recommended.

The low impedance fixing of the mounting rails with the mounting system using screws or rivets is recommended. With painted, anodised or insulated metal parts the insulating layer must be removed in the connection area. The connection point must be protected from corrosion (e.g. by greasing).

**Caution!**

Only special, suitable grease must be used.

---

**System SmartWire for  
Safety Relevant  
Applications**

For most applications, apart from normal operational switching also the switch-off in emergency or the switch-off by the opening of the protective doors is demanded.

The system SmartWire is not designed for the transfer of safety relevant signals. Using the following configuration (→ figure 16, page 41) the system SmartWire can however be used for safety relevant switch-offs.



---

**Danger!**

In safety-relevant applications the power supply providing power to the SmartWire system must feature a PELV power supply unit (protective extra low voltage).

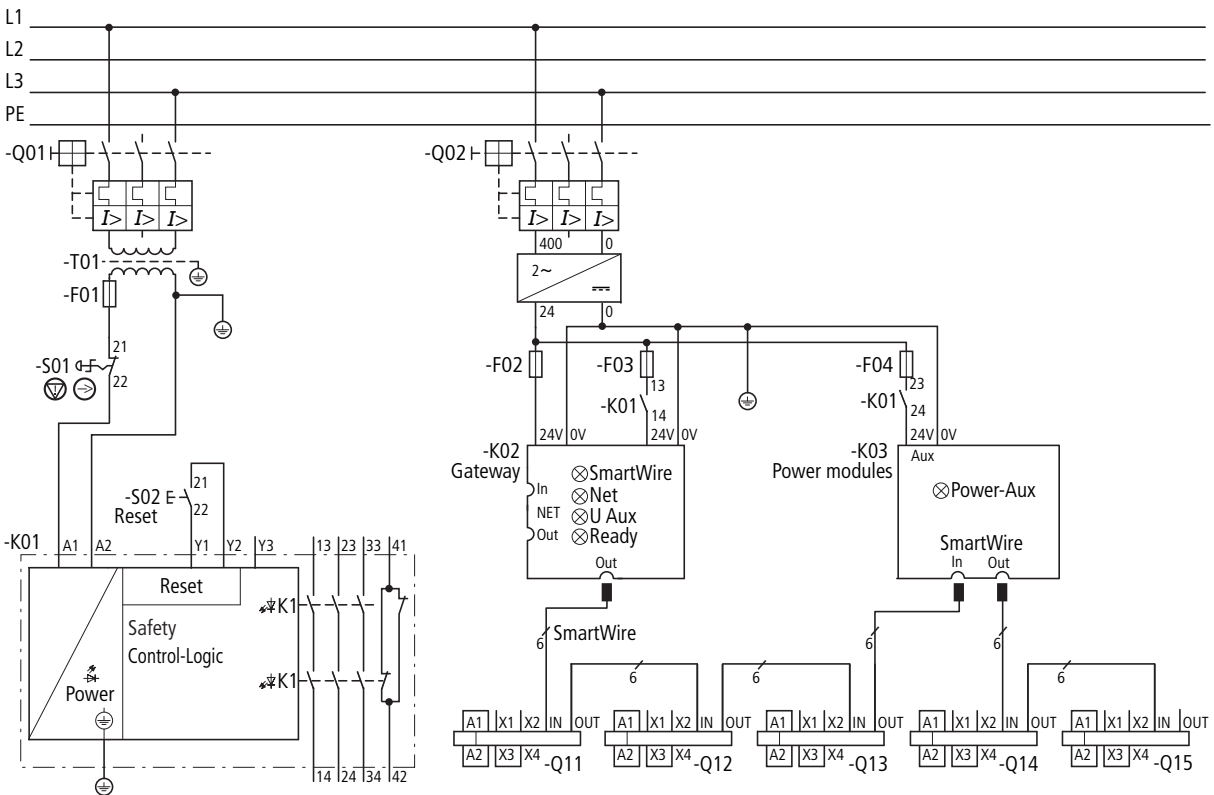

Figure 16: Circuit diagram for safety-relevant switch-offs

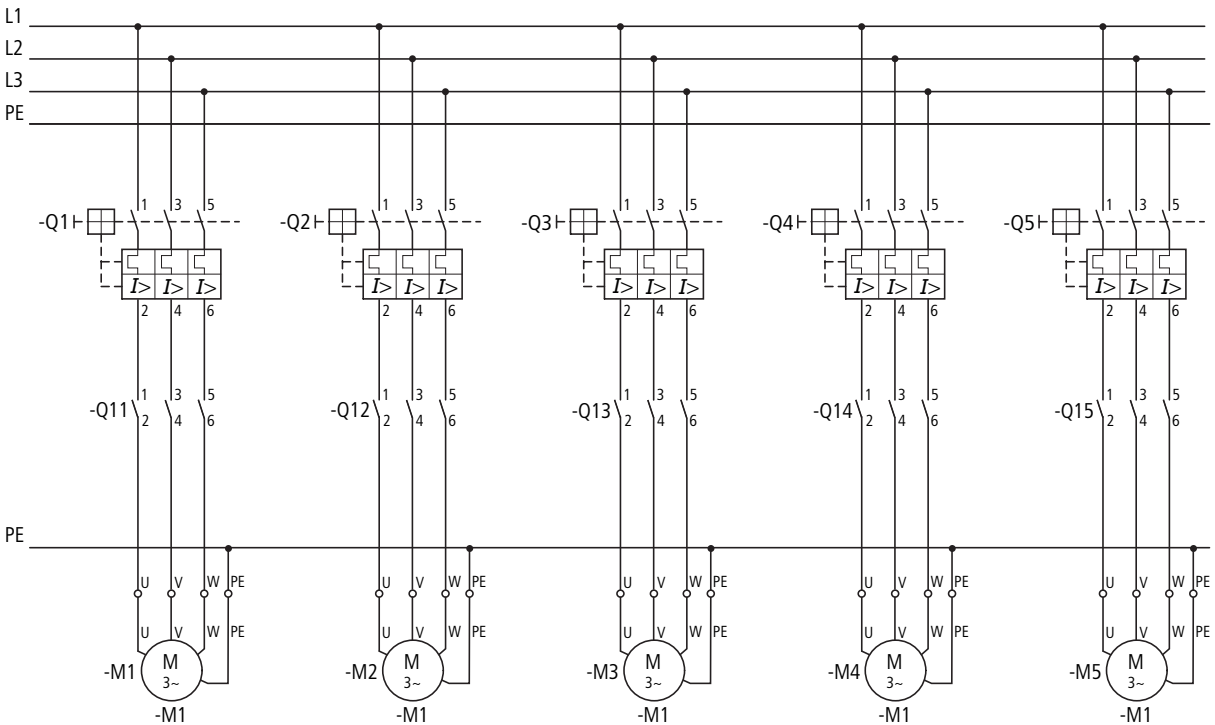

Figure 17: Mains circuit for safety relevant switch-offs

In an emergency, the power for the contactor coils can be switched off using the enable circuit of the safety relay. By the use of extra SmartWire Power modules protection groups are made that in an emergency can be switched off together. With this circuitry, controls can be assembled up to Safety Category 1 to EN 954-1.

### **Feedback circuit**

The auxiliary contact integrated in the contactor is a mirror contact according to IEC/EC 60947-4-1. Using this contact the state of the main contacts can be reliably signalled. The mirror contact can be included into the feedback circuit of the safety relay so that the safety relay only gives a new enable signal when the contactor is open.

### **Measures to achieve a higher safety category**

In many applications controls compliant to safety category 3 or 4 to EN 954-1 are required. Controls compliant to category 3 can be established with an additional group contactor which is connected in series upstream of the motor outgoers. The control voltage for the motor contactor as well as for the group contactor is switched off via the safety relay in an emergency. The redundant switch-off also enables implementation of category 3 controls.

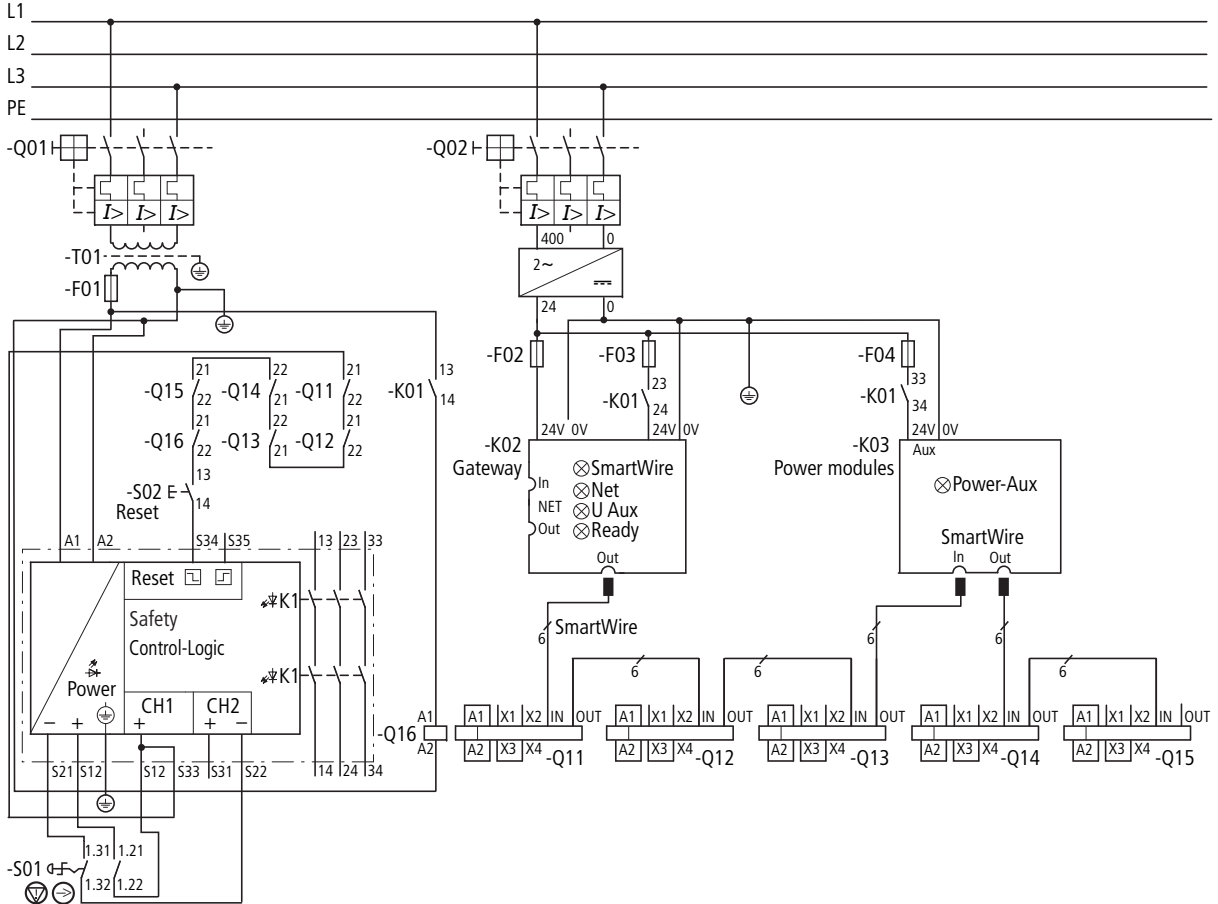

Figure 18: Control circuit for redundant switch-off



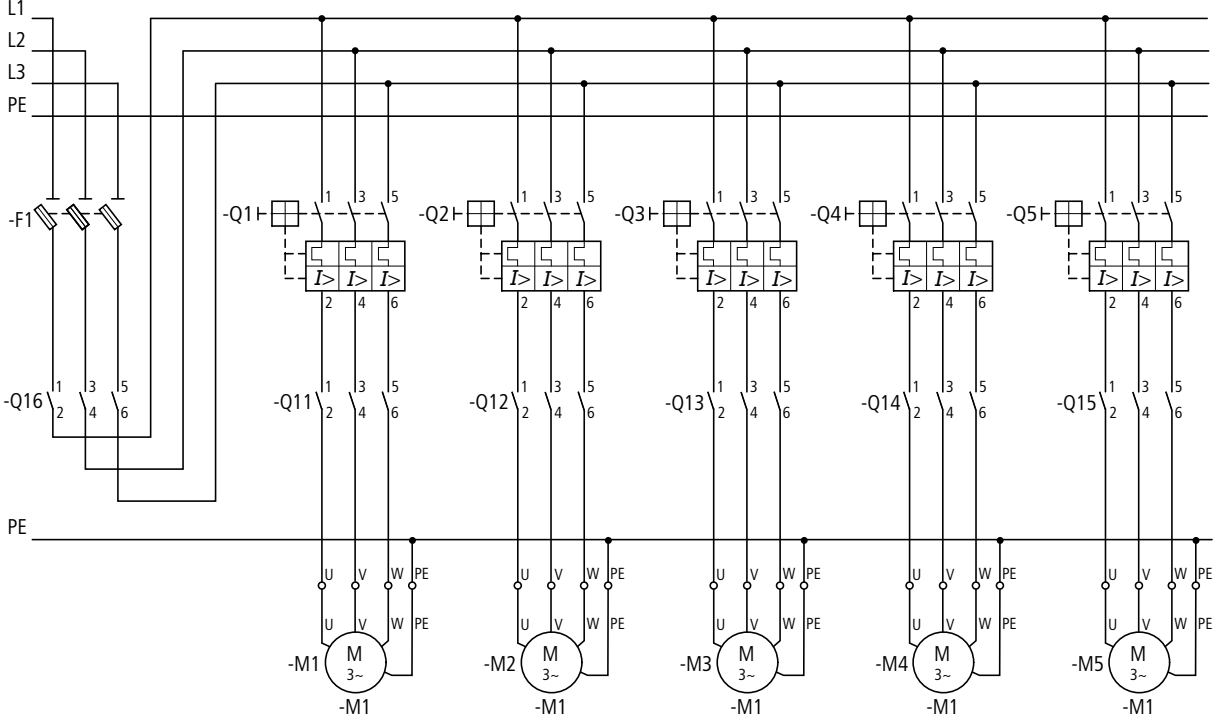

Figure 19: Mains circuit for redundant switch off

**Danger!**

The total assembly of the safety relevant controls must correspond to the required safety category.

**System SmartWire for Applications in North America**

For applications for the North American market special care must be taken with the approval of the individual components of the system SmartWire.

**DOL starters**

With the use of DOL starters in the North American market various special features must be observed that are based on market practices and the associated Standards.



A comprehensive overview is given by the Eaton publication "Special Conditions for application of motor-protective circuit-breakers and motor starters in North America" VER1210+1280-928 (→ [http://www.moeller.net/binary/ver\\_techpapers/ver928en.pdf](http://www.moeller.net/binary/ver_techpapers/ver928en.pdf)).

**Reversing starters**

Apart from the special features described in section „DOL Starter“ it must be taken into account that reversing starters in the North American market must be fitted with a mechanical and electrical interlock. The electrical interlock is carried out using terminals X3-X4 (→ section "Combination with Eaton Switchgear", page 17).

## 4 Commissioning

The connection of system SmartWire to the PLC takes place via a gateway.

The different gateways and the commissioning are described in separate manuals.

- PROFIBUS-DP: SWIRE-GW-DP  
MN03407001Z-EN (previously AWB1251-1590GB)
- easyNET and CANopen: EASY223-SWIRE  
MN05006003Z-EN (previously AWB2528+1251-1589GB)
- I/O system XI/ON manual, supplier, company  
MicroInnovation AG, [www.microinnovation.com](http://www.microinnovation.com),  
Switzerland

The manuals are available for download on the Internet as PDF files. They can be quickly located at <http://www.moeller.net/en/support/index.jsp> by entering the document number as the search term.



---

**Danger!**

Before the commissioning the system must be completely mounted and wired.



## 5 Diagnostics and fault signals

**LED Diagnostic Signals** The individual components of the system SmartWire give fault signals by LED.

Table 6: Diagnostics messages gateway

Part	LED Design.	Colour	State	Message
Gateway	Bus	→ Gateway manual (chapter "Overview SmartWire System", page 7)		
	SmartWire	Green	Continuous lighting	OK
			Slow flashing	Error, actual configuration of the slave dies not correspond with the target configuration in the gateway
			Fast flashing	Cycle fault in SmartWire system
			Off	No voltage on gateway
	U Aux	Green	Continuous lighting	OK
			Off	No voltage on the terminal Aux
	Ready	Green	Continuous lighting	OK
			Slow flashing	Master PLC in STOP mode
			Fast flashing	New configuration has been activated via the configuration button
			Off	No voltage or internal fault in the gateway

Table 7: Diagnostics message SmartWire power module

Part	LED			
	Design.	Colour	State	Message
Power module	U <sub>Aux</sub>	Green	Continuous lighting	OK
			Off	No voltage on the terminal Aux

Table 8: Diagnostic messages SmartWire module for DILM

Part	LED			
	Design.	Colour	State	Message
SmartWire module for DILM	Ready	Green	Continuous lighting	OK
			Flashing	Device is not in the configuration, first faulty device in the series – no communication
			Pulse flashing	SmartWire module for DILM has voltage, previous devices has caused fault – no communication
			Off	No voltage on gateway or device defective.

Table 9: Diagnostics messages SmartWire I/O module

Part	LED			
	Design.	Colour	State	Message
SmartWire I/O module	Q1	Green	Continuous lighting	Relay 1 switched
			Off	Relay 1 open
	Q2	Green	Continuous lighting	Relay 2 switched
			Off	Relay 2 open
	Ready	Green	Continuous lighting	OK
			Flashing	Device is not in the configuration, first faulty device in the series – no communication
			Pulse flashing	SmartWire module for DILM has voltage, previous devices has caused fault – no communication
			Off	No voltage on gateway or device defective.

---

Exchange of Modules

SmartWire module for DILM



---

**Danger!**

The exchange of the SmartWire module for DILM must only be carried out with the supply switched off.

After the exchange and the reconnection of the supply the configuration button must be pressed. Then the new module is assigned the address.



---

**Caution!**

The order of the SmartWire units must not be altered.

Motor starter or contactor



---

**Warning!**

The exchange of the motor starter or contactor must only be carried out after the complete system SmartWire is switched off.



**Fault-finding**

For fault localisation the status signals on the LEDs of the components of the system SmartWire are used. In the following table 10 the correct function of the components not described is assumed.

Table 10: Fault signals

No.	Part	Design.	State of LED	Error message	Remedy
1	Gateway	Bus	Flashing	No communication to field bus	<ul style="list-style-type: none"> <li>• Check master</li> <li>• Check bus plug on gateway</li> <li>• Check address allocation</li> </ul>
2	Gateway	Bus SmartWire Ready	Off	No voltage on gateway	<ul style="list-style-type: none"> <li>• Check gateway power supply</li> <li>• Check wiring, mains unit to gateway</li> <li>• Check gateway fuse protection</li> </ul>
3	Gateway	U Aux	Off	No contactor power supply	<ul style="list-style-type: none"> <li>• Check mains unit for contactor coil power supply</li> <li>• Check wiring, mains unit to gateway</li> <li>• Check contactor coils fuse protection</li> </ul>

No.	Part	Design.	State of LED	Error message	Remedy
4	Gateway	SmartWire	Flashing	Configuration of the unit is not correct	<ul style="list-style-type: none"> <li>• Check plug connection</li> <li>• Press configuration button after exchange of device</li> </ul>
	SmartWire module for DILM or SmartWire I/O module	Ready			
	The following SmartWire modules for DILM or SmartWire I/O modules.	Ready	Pulse flashing		
5	Gateway	SmartWire Ready	Flashing	SmartWire is interrupted	<ul style="list-style-type: none"> <li>• Check the plug connector on the SmartWire slaves</li> <li>• Check connection cable for damage and replace if necessary</li> </ul>
	On a slave all SmartWire modules for DILM or SmartWire I/O modules flash.				
6	Power module	U Aux	Off	No contactor power supply	<ul style="list-style-type: none"> <li>• Check mains unit for contactor coil power supply</li> <li>• Check wiring, mains unit to Power module</li> <li>• Check contactor coils fuse protection</li> </ul>

No.	Part	Design.	State of LED	Error message	Remedy
7	SmartWire module for DILM or SmartWire I/O module	Ready	Off	Internal error in the SmartWire module for DILM	Exchange the SmartWire module for DILM
	Gateway	SmartWire	Flashing		
8	SmartWire module for DILM or SmartWire I/O module	Ready	Off	No communication in system SmartWire	<ul style="list-style-type: none"> <li>• Check the plug connector on the SmartWire slaves</li> <li>• Check connection cable for damage and replace if necessary</li> <li>• Exchange the module</li> </ul>
9	SmartWire module for DILM	All LEDs	ON	Contacting does not pull in	<ul style="list-style-type: none"> <li>• Ensure that the slider for mechanical mounting is in the correct position</li> <li>• Set connection pins to device type DILM (→ fig. 7, page 24)</li> <li>• Check the connection pins of the SmartWire for DILM for damage</li> <li>• Check if bridge X3-X4 is available on SWIRE-DIL</li> </ul>

No.	Part	Design.	State of LED	Error message	Remedy
10	Gateway	SmartWire	Fast flashing	Failure of a SmartWire slave in operation	<ul style="list-style-type: none"><li>• Switch the gateway supply off and on again</li><li>• Check connection cable</li></ul>

## Appendix

Technical data		General		
		SWIRE-PF	SWIRE-4DI-2DO-R	SWIRE-DIL
Standards and regulations		IEC/EN 60947, EN 55011, EN 55022, IEC/EN 61000-4, IEC/EN 60068-2-27		
Mounting		Top hat rail EN 50022, 35 mm or screw fixing with device feet ZB4-101-GF1 (accessory)		on DILM7 - DILM32
Dimensions W × H × D	mm	35 x 90 x 74	35 x 90 x 74	45 x 44 x 81
Weight	kg	0.1	0.12	0.04
Terminal capacity				
Solid	mm <sup>2</sup>	0.5 - 1.5	0.5 - 1.5	0.5 - 1.5
Flexible with ferrule	mm <sup>2</sup>	0.5 - 1.5	0.5 - 1.5	0.5 - 1.5
Solid or stranded	AWG	22 - 16	22 - 16	22 - 16
Standard screwdriver	mm	3.5 x 0.8	3.5 x 0.8	3.5 x 0.8
Maximum torque	Nm	0.6	0.6	0.5

**Environmental conditions**

		SWIRE-PF	SWIRE-4DI-2DO-R	SWIRE-DIL
Ambient climatic conditions				
Ambient temperature operation (Cold to IEC 60068-2-1, warm to IEC 60068-2-2)	°C	-25 - 55	-25 - 55	-25 - 60
Condensation		Prevent condensation with suitable measures		
Ambient temperature for storage	°C	-25 - 70	-25 - 70	-25 - 70
Relative humidity, non-condensing (IEC/EN 60068-2-30)	%	5 - 95	5 - 95	5 - 95
Air pressure (operation)	hPa	795 - 1 080	795 - 1 080	795 - 1 080
Ambient mechanical conditions				
Degree of protection, IEC/EN 60529		IP20	IP20	IP20
Pollution degree		2	2	2
Mounting position		Vertical	Vertical	as DILM7 - DILM32

### Electromagnetic compatibility

		SWIRE-PF	SWIRE-4DI-2DO-R	SWIRE-DIL
Electrostatic discharge IEC/EN 61000-4-2, Level 3, ESD				
Air discharge	kV	8	8	8
Contact discharge	kV	6	6	6
Electrical field EC/EN 61000-4-3, RFI	V/m	10	10	10
Radio interference suppression EN 55011, EN 55022		Class A	Class A	Class A
Burst Impulse EC/EN 61000-4-4, Level 3				
AC supply cable	kV	2	2	2
High-energy pulses (surge) IEC/EN 61000-4-5, Level 2	kV	0.5 (supply cables, symmetrical)		
Immunity to line-conducted interference IEC/EN 61000-4-6	V	10	10	10
Dielectric strength				
Dimensioning of clearance and creepage distances		EN 50178, EN 60947-1, UL 508, CSA C22.2 No 142		
Dielectric strength		EN 50178, EN 60947-1		

### Supply voltage

(power supply for switching SmartWire elements e.g. contactor coils)

		SWIRE-PF	SWIRE-4DI-2DO-R	SWIRE-DIL
Supply voltage $U_{AUX}$				
Rated operational voltage $U_{AUX}$	V DC	24, -15 %, +20 % (derating from > 40 °C)	Supply from Gateway or Power module	
Permissible range	V DC	20.4 - 28.8 at 45 °C: 21 - 28.8 at 50 °C: 21.6 - 28.8 at 55 °C: 22.2 - 27.6	Supply from Gateway or Power module	
Input current $U_{AUX}$ at 24 V DC	A	Normally 3	–	–
Residual ripple	%	≤ 5	–	–
Voltage dips, IEC/EN 61131-2	ms	10	–	–
Protection against polarity reversal		Yes	–	–
Short-circuit protection SmartWire side		No, external 3 A fuse necessary, MCB FAZ-Z3	–	–



**LED**

	SWIRE-PF	SWIRE-4DI-2DO-R	SWIRE-DIL
Ready for operation	–	Ready: green	Ready: green
Power supply SmartWire module for DILM	U <sub>Aux</sub> : green	–	–
Status Outputs	–	Q1: Green Q2: Green	–

**Connectionn potential-free contacts**

		SWIRE-PF	SWIRE-4DI-2DO-R	SWIRE-DIL
Input for potential-free contacts				
Number		–	4	1
Rated voltage (own supply)	V DC	–	17	17
Input current at state "1"	mA	–	Normally 5	Normally 5
Potential separation		–	No	No
Max. cable length	m	–	< 2.8	< 2.8

**Relay outputs**

		<b>SWIRE-4DI-2DO-R</b>
Rated impulse withstand voltage $U_{imp}$	V AC	4000
Overvoltage category/degree of pollution		III/3
Rated insulation voltage $U_i$	V	250
Rated operational voltage $U_e$	V	250
Making capacity	A	30
Breaking capacity	A	10
Rated operational current $I_e$		
AC-15, 250 V	A	3
DC-12, 30 V	A	3
Conventional free air thermal current $I_{th}$	A	4
Short-circuit rating without welding		
Max. fuse	A gG/gL	10

## SmartWire modules

	SWIRE-PF	SWIRE-4DI-2DO-R	SWIRE-DIL
Connection types	Plug, 6-pole	Plug, 6-pole	Plug, 6-pole
Data/power cable	6 core flat-band cable		
Total of the system SmartWire cable lengths	4 m	4 m	4 m
Termination SmartWire system	No	Termination connector	Termination connector
Station address	None	1 - 16	1 - 16
Stations per SmartWire rung	Maximal 4	Maximal 4	Maximal 16
Address allocation	None	Automatic via SmartWire	
Potential separation			
from supply voltage $U_{Aux}$	No	No	No
from supply voltage $U_{Gateway}$	No	No	No
Function	No SmartWire station	SmartWire slave	SmartWire slave
Data transfer time System SmartWire			
Write switch	–	typically 20 ms for all units	
Read status information	–	typically 10 ms per unit	



# Index

<b>A</b>	Auxiliary contacts .....	10
<hr/>		
<b>C</b>	Catch slider .....	10
	Components .....	7
	Connection cable .....	7, 14
	Connection pins .....	10
	Contactors .....	17
	Contactors .....	15
<hr/>		
<b>D</b>	Data Transfer .....	20
	Diagnostic messages	
	SmartWire I/O module .....	51
	SmartWire power module .....	50
	Diagnostics messages	
	Gateway .....	49
<hr/>		
<b>E</b>	Earth .....	27, 37
	Earthing .....	38
	EMC measures .....	38
	Error messages .....	53
<hr/>		
<b>F</b>	Feedback circuit .....	43
<hr/>		
<b>G</b>	Gateway .....	7, 49
<hr/>		
<b>I</b>	I/O module .....	7, 12, 18
	Inputs and outputs .....	12
	for circuit-breakers .....	19
	for motor-protection circuit-breakers .....	19
	for soft starters .....	19

<hr/>	
<b>L</b>	LEDs ..... 10, 12, 13 Error messages ..... 53
<hr/>	
<b>M</b>	Mirror contact ..... 43 Module for DILM ..... 7, 10, 17 Motor starters ..... 15 Mounting Rails ..... 39
<hr/>	
<b>P</b>	PELV ..... 40 Power module ..... 7, 13 Programmable logic controller ..... 3
<hr/>	
<b>R</b>	Reaction time ..... 20 Read ..... 21 Relay outputs ..... 12
<hr/>	
<b>S</b>	Safety categories ..... 43 Setting slider ..... 24 Slider Setting ..... 24 SmartWire Components ..... 7 Connection cable ..... 7, 14 Connection system ..... 9 I/O-module ..... 7, 12 Module for DILM ..... 7, 10 Power module ..... 7, 13 Rung ..... 11 Terminal plug ..... 7, 16 Star-point ..... 27, 37 Switching position indicator ..... 10
<hr/>	
<b>T</b>	Terminal plug ..... 7, 16
<hr/>	
<b>W</b>	Write ..... 21