

Connection System SmartWire SWIRE-GW-DP



Powering Business Worldwide

All brand and product names are trademarks or registered trademarks of the owner concerned.

Emergency On Call Service

Please call your local representative:

<http://www.eaton.com/moeller/aftersales>

or

Hotline of the After Sales Service:

+49 (0) 180 5 223822 (de, en)

AfterSalesEGBonn@eaton.com

Original Operating Instructions

The German-language edition of this document is the original operating manual.

Translation of the original operating manual

All editions of this document other than those in German language are translations of the original German manual.

1st published 2006, edition date 11/06

© 2006 by Eaton Industries GmbH, 53105 Bonn

Production: Heidrun Riege

Translation: David Long

All rights reserved, including those of the translation.

No part of this manual may be reproduced in any form (printed, photocopy, microfilm or any other process) or processed, duplicated or distributed by means of electronic systems without written permission of Eaton Industries GmbH, Bonn.

Subject to alteration without notice.



Danger!

Dangerous electrical voltage!

Before commencing the installation

- Disconnect the power supply of the device.
- Ensure that devices cannot be accidentally restarted.
- Verify isolation from the supply.
- Earth and short circuit.
- Cover or enclose neighbouring units that are live.
- Follow the engineering instructions (IL/AWA) of the device concerned.
- Only suitably qualified personnel in accordance with EN 50110-1/-2 (VDE 0105 Part 100) may work on this device/system.
- Before installation and before touching the device ensure that you are free of electrostatic charge.
- The functional earth (FE) must be connected to the protective earth (PE) or to the potential equalisation. The system installer is responsible for implementing this connection.
- Connecting cables and signal lines should be installed so that inductive or capacitive interference does not impair the automation functions.
- Install automation devices and related operating elements in such a way that they are well protected against unintentional operation.
- Suitable safety hardware and software measures should be implemented for the I/O interface so that a line or wire breakage on the signal side does not result in undefined states in the automation devices.
- Ensure a reliable electrical isolation of the low voltage for the 24 volt supply. Only use power supply units complying with IEC 60364-4-41 (VDE 0100 Part 410) or HD 384.4.41 S2.
- Deviations of the mains voltage from the rated value must not exceed the tolerance limits given in the specifications, otherwise this may cause malfunction and dangerous operation.
- Emergency stop devices complying with IEC/EN 60204-1 must be effective in all operating modes of the automation devices. Unlatching the emergency-stop devices must not cause restart.
- Devices that are designed for mounting in housings or control cabinets must only be operated and controlled after they have been installed with the housing closed. Desktop or portable units must only be operated and controlled in enclosed housings.

- Measures should be taken to ensure the proper restart of programs interrupted after a voltage dip or failure. This should not cause dangerous operating states even for a short time. If necessary, emergency-stop devices should be implemented.
- Wherever faults in the automation system may cause damage to persons or property, external measures must be implemented to ensure a safe operating state in the event of a fault or malfunction (for example, by means of separate limit switches, mechanical interlocks etc.).

Contents

	About this manual	3
	Intended users	3
	Additional device manuals	3
	Reading convention	4
<hr/>		
1	About the PROFIBUS-DP gateway	
	SWIRE-GW-DP	5
	System overview	5
	Design of the SWIRE-GW-DP	6
	Description of function	6
<hr/>		
2	Installation	9
	Set PROFIBUS-DP station address	9
	Connect SmartWire connection cable	10
	Connect supply voltages	11
	Connect PROFIBUS-DP	12
	Connection assignment PROFIBUS-DP	13
	Terminating resistors	14
	EMC-conformant wiring of the network	14
	Potential separations	15
	Data transfer rates – automatic baud rate detection	16
	Maximum distances/bus cable lengths	16
<hr/>		
3	Commissioning	19
	Initial switch on	19
	Meaning of the status LEDs	20
	– Ready-LED	20
	– U-Aux-LED	20
	– SmartWire LED	21
	– PROFIBUS LED	21

4 PROFIBUS-DP functions	23
Configuration of the DP master	23
Slave modules	24
– Universal module	24
– SWIRE-DIL module	24
– SWIRE-4DI-2DO-R module	25
Diagnostic data	26
– Diagnostics information format	27
– Meaning of the diagnostics information	29
GSD file	32
Fault-finding	33

Appendix	35
Technical Data	35
– General	35
– Environmental conditions	36
– Electromagnetic compatibility (EMC)	37
– Dielectric strength	37
– Power supply voltages	38
– LED displays	39
– PROFIBUS-DP	39
– SmartWire system	40
Dimensions	41

Index	43
--------------	-----------

About this manual

Intended users

This manual is intended for automation technicians and engineers. Extensive knowledge regarding the PROFIBUS-DP fieldbus and programming of a PROFIBUS-DP master are assumed. Furthermore, you should also be familiar with the handling of the SmartWire system.

Additional device manuals

Further information concerning the SmartWire topic can be found in:

- Connection system SmartWire, modules MN03402001Z-EN (previously AWB1210+1251-1591),
- Connection system SmartWire, EASY223-SWIRE MN05006003Z-EN (previously AWB2528+1251-1589).

The manuals are available for download on the Internet as PDF files.

They can be quickly located at

<http://www.moeller.net/en/support/index.jsp>

by entering the document number as the search term.

Reading convention

Symbols used in this manual have the following meanings:

► Indicates instructions to be followed.



Attention!

Warns of the risk of material damage.



Caution!

Warns of the possibility of serious damage and slight injury.



Danger!

Indicates the risk of major damage to property, or serious or fatal injury.



Draws your attention to interesting tips and supplementary information.

For greater clarity, the name of the current chapter is shown in the header of the left-hand page and the name of the current section in the header of the right-hand page. This does not apply to pages at the start of a chapter and empty pages at the end of a chapter.

1 About the PROFIBUS-DP gateway SWIRE-GW-DP

The communication module SWIRE-GW-DP has been developed for automation tasks with the PROFIBUS-DP fieldbus. The SWIRE-GW-DP is a gateway and can only be operated in conjunction with the SmartWire system. The PROFIBUS-DP gateway always operates with a modular DP slave in the PROFIBUS-DP network.

System overview

The SmartWire connection system is integrated into a PROFIBUS-DP system as a modular DP slave.

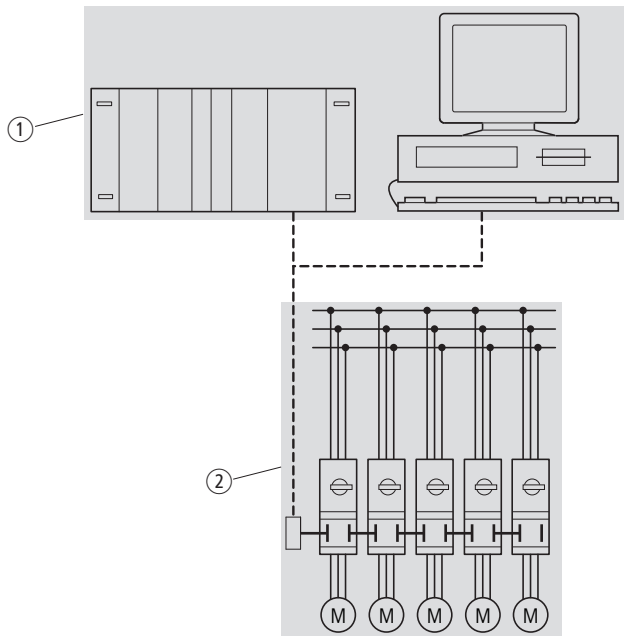

Figure 1: Integration of the SWIRE-GW-DP in a DP network

- ① Master area, PLC or PC
- ② Slave area with SmartWire system

Design of the SWIRE-GW-DP

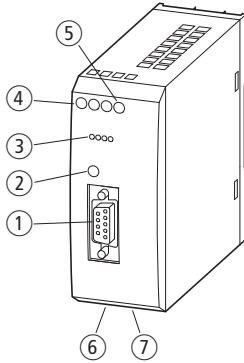

Figure 2: Device view

- ① Connection to PROFIBUS_DP, 9-pole SUB-D socket, → page 12
- ② Configuration button, → page 19
- ③ 4 green status LEDs, → page 20
- ④ Gateway power supply terminal, → page 11
- ⑤ Contactor coil (aux.) power supply terminal, → page 11
- ⑥ Socket Out for SmartWire connection cable, → page 10
- ⑦ DIP switch for the address setting of the PROFIBUS-DP module, → page 9

Description of function

The gateway SWIRE-GW-DP enables the connection of the SmartWire system to a PROFIBUS-DP communication network. The SmartWire system can consist of a line with a maximum of 16 slaves. The slaves can be either SmartWire modules for DILM or SmartWire I/O modules. The following data can be transmitted by the selection of the corresponding SmartWire modules:

- SmartWire module for DILM

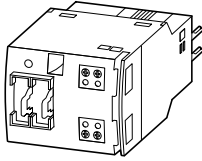

Figure 3: SWIRE-DIL

- Contactor switching state feedback and PKZM0 switching state feedback
(Read, as viewed from the PROFIBUS-DP master)
- Contactor control ON/OFF
(Write, as viewed for PROFIBUS-DP master)

- SmartWire-I/O module

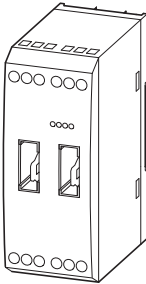

Figure 4: SWIRE-4DI-2DO-R

- Input data of the SmartWire modules (4 bit)
(Read, as viewed from PROFIBUS-DP master)
- Control of the relay outputs of the SmartWire module
(2 bit)
(Write, as viewed by the PROFIBUS-DP master)

2 Installation

Set PROFIBUS-DP station address

Every PROFIBUS-DP slave requires its own unique address in the PROFIBUS-DP network.

The PROFIBUS-DP address in the SWIRE-GW-DP is set using 7 DIP switches 2 to 8 in binary format. DIP switch 1 is not assigned with a function. Accordingly addresses 0 to 127 can be set. Valid addresses for the SWIRE-GW-DP in the PROFIBUS-DP are 1 to 125.

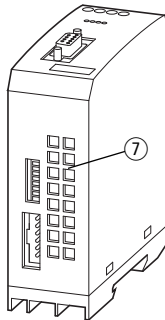

Figure 5: Bottom of device SWIRE-GW-DP

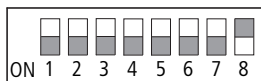

Figure 6: Default delivery setting SWIRE-GW-DP (address 126)

- ▶ Set the slave address on DIP switch ⑦ on the bottom of the gateway in the PROFIBUS-DP (→ page 10).

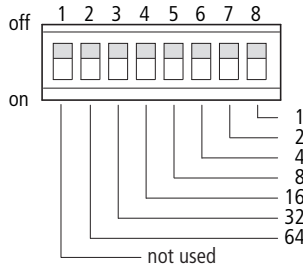

Figure 7: Setting of the slave address

Connect SmartWire connection cable

The slaves in the SmartWire system are connected using 6-pole connection cables available in different lengths (→ MN03402001Z-EN). The cables feature connectors at both ends.

- ▶ Insert the 6-pole SmartWire connection cable into the OUT socket on the bottom of the device.

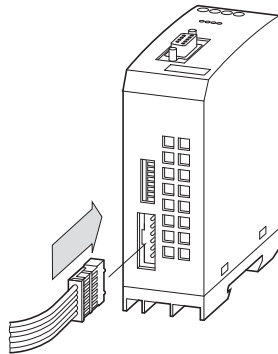

Figure 8: Connecting SWIRE-GW-DP

- ▶ Connect the other SmartWire stations.



Attention!

The total cable length of the SmartWire line may not exceed a maximum of 400 cm.

Connect supply voltages

The gateway SWIRE-GW-DP is operated with a 24 V DC supply voltage (→ chapter "Technical Data", page 35). An additional 24 V DC control voltage is provided for the contactor coils.

- ▶ Connect the SWIRE-GW-DP via the connection terminals 24 V and 0 V to the 24 V DC power supply.
- ▶ Connect the 24 V DC control voltage for the contactor coils via the connection terminals Aux 24 V and 0 V.

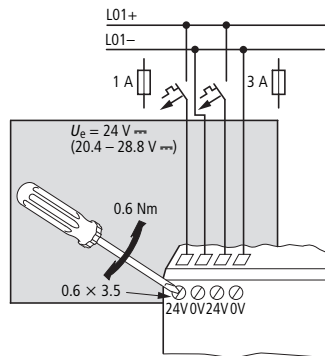

Figure 9: Connecting the power supply

The terminals are suitable for cables from AWG22 to AWG16 or for stranded cables with a cross-section of 0.5 to 1.5 mm². The terminals must be tightened with a torque of 0.6 Nm.



The gateway is protected by a 1 A gG/gL line protection fuse or a 1 A miniature circuit-breaker featuring characteristic C.

The fusing of the incoming supply for the contactor coils is implemented using 3 A gG/gL fuses or a 3 A miniature circuit-breaker featuring characteristic Z.

**Danger!**

In safety-relevant applications the power supply providing power to the SmartWire system must feature a PELV power supply unit (protective extra low voltage).

Connect PROFIBUS-DP

The SWIRE-GW-DP is connected to the PROFIBUS-DP fieldbus with a special PROFIBUS-DP cable from the Moeller accessory range.

- ▶ Connect the 9-pole SUB D connector of the PROFIBUS-DP cable to the SUB D connector.

The cable type has an influence on the maximum available bus cable length and thus on the data transfer rate.

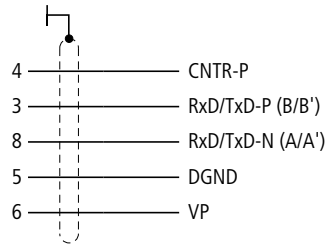
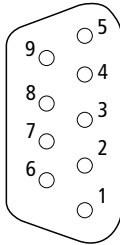
Connection assignment
PROFIBUS-DP

Pin	Signal name	Designation
1	not used	–
2	not used	–
3	R×D/T×D-P (B line)	Receive/Send data P
4	CNTR-P/RTS	Request to Send
5	DGND	Data ground
6	VP	+5 V DC for external bus termination
7	not used	–
8	R×D/T×D-N (A line)	Receive/Send data P
9	not used	–

The terminals 3, 8 and shield are enough for data transfer.

Terminating resistors

The first and last slaves of a PROFIBUS-DP fieldbus segment must be terminated with a switched on terminating resistor. The bus termination resistors are connected externally. The external connection can be implemented either with a separate terminating resistor or by a special SUB D connector.

The PROFIBUS-DP data plug from Moeller allows switching on and off both termination resistors.

EMC-conformant wiring of the network

Undesired faults can occur on the fieldbus due to electromagnetic interference. They can be minimised beforehand by the implementation of suitable EMC measures. These include:

- EMC-conformant system configuration,
- EMC compliant cable installation and
- measures which do not allow potential differences to occur,
- correct installation of the PROFIBUS system (cables, connection of the bus connectors, ...).

The electromagnetic interference can be significantly reduced by the use of a cable screen (shield). The following illustration indicates the correct method for connection of the shield.

for top-hat rail

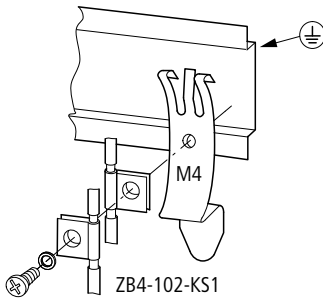

for mounting plate

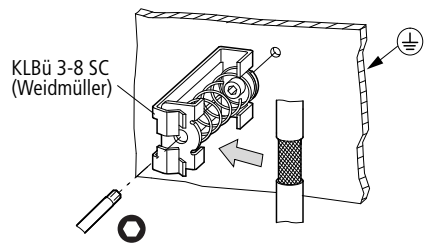
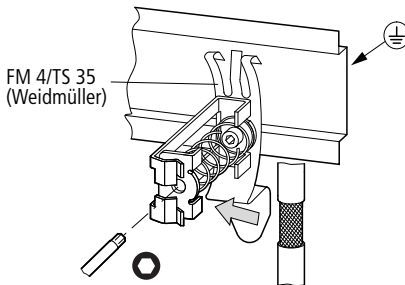
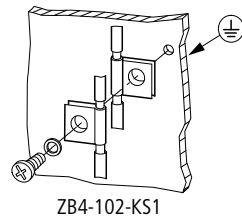

Figure 10: Shielding of network cable

Potential separations

The following electrical isolation measures apply for the SWIRE-GW-DP interfaces:

- Potential isolation of the PROFIBUS-DP to the supply voltage and to the SmartWire system,
- No isolation between the supply voltage for the gateway and the supply voltage for the contactor coils,
- No potential isolation between the supply voltages and the SmartWire system.

Data transfer rates – automatic baud rate detection

After switch on the gateway SWIRE-GW-DP automatically detects the baud rate used in the PROFIBUS-DP network. However, at least one slave in the network must transfer data in order for the detection to be possible.

The following baud rates are supported:

- 9.6 - 12,000 kBit/s.

Maximum distances/bus cable lengths

Two bus cable variants are specified in the IEC 61158. Cable type B should no longer be used with new applications as it is out of date. With cable type A all baud rates up to 12 000 kbit/s can be used. In addition to the standard cable, there are also cables available for underground installation, festooned cables and trailed cables.

Table 1: Cable parameters

Parameters	Cable type A
Surge impedance [Ω]	135 - 165 at 3 - 20 MHz
Effective capacitance [$\mu\text{F}/\text{m}$]	< 30
Loop resistance [Ω/km]	< 110
Conductor diameter [mm]	> 0,64
Core cross-section [mm^2]	> 0.34

The following bus segment lengths result from specified cable parameters.

Distance between two slaves if cable type A to IEC 61158 is used.

Table 2: Cable type A

Baud rate [kBit/s]	Max. cable length Cable type A [m]
9.6	1200
19.2	1200
93.75	1200
187.5	1000
500	400
1500	200
3000	100
6000	100
12000	100

Distance between two slaves if cable type B to IEC 61158 is used.

Table 3: Cable type B

Baud rate [kBit/s]	Max. cable length Cable type B [m]
9.6	1200
19.2	1200
93.75	1200
187.5	1000
500	400
1500	–

3 Commissioning

- ▶ Before switching on the supply voltage for the gateway ensure that the contactor coils, the bus connection and the SmartWire system are correctly connected.

Initial switch on

- ▶ Verify that the DIP switch of the PROFIBUS-DP address of the gateway is set, → page 9.
- ▶ Switch on the supply voltages for the contactors and the gateway.

The LEDs now have these states:

- The ready LED of the SWIRE-GW-DP flashes,
 - The U-Aux LED of the SWIRE-GW-DP is permanently ON,
 - The PROFIBUS LED is OFF (no communication via PROFIBUS-DP),
 - The SmartWire LED flashes as the SmartWire slaves have not yet been configured,
 - The first SmartWire module flashes the ready LED,
 - The ready LEDs on all other SmartWire modules flash in pulses.
- ▶ Press the configuration button on the gateway and keep it pressed for about 2 s until the ready LED switches from flow flashing to fast flashing.

The actual configuration of the SmartWire system, i.e. all connected and interconnected modules SWIRE-DIL and SWIRE-4DI-2DO-R are read in the gateway. The SmartWire slaves are assigned with sequential addresses in ascending order starting at 1. After successful acceptance of the system configuration on the SmartWire system, the slowly flashing SWIRE status LED on the PROFIBUS-DP gateway and the ready LEDs of the SmartWire module switch to permanently ON. The SmartWire system continuously compares the saved hardware configuration with the existing configuration.

If there are any divergences they are indicated by a slowly flashing SmartWire LED (→ section “Diagnostic data”, page 26).

- ▶ Switch in the PROFIBUS-DP fieldbus.
As soon as the gateway is integrated into the PROFIBUS-DP network the BUS LED will light up permanently.



Valid data will only be sent via the PROFIBUS-DP to the gateway once the PROFIBUS LED stays permanently ON.

- ▶ Switch in the PROFIBUS-DP master. to “run”.
The Ready LED on the PROFIBUS-DP gateway switches from flashing to permanently ON.

Meaning of the status LEDs

The gateway SWIRE-GW-DP features four green status LEDs.

Ready-LED

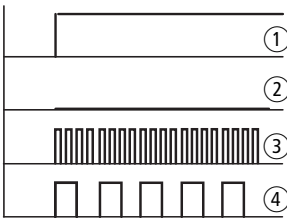

①	Continuous light	Supply voltage available
②	OFF	No supply voltage available for the gateway and the SmartWire or internal fault in the gateway
③	Fast flashing	New configuration has been activated via the configuration button
④	Slow flashing	PROFIBUS-DP master im STOP mode

U-Aux-LED

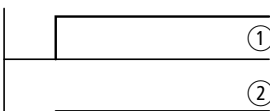

①	Continuous light	Supply voltage available for the contactor coils
②	OFF	No supply voltage available

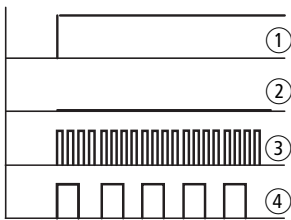
SmartWire LED

①	Continuous light	SmartWire system is ok
②	OFF	No supply voltage available on the PROFIBUS-DP gateway
③	Fast flashing	Transmission error in the SmartWire system
④	Slow flashing	Error in the configuration of the SmartWire system, target and actual configuration do not match

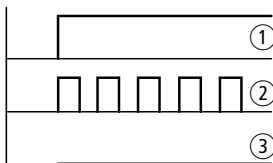
PROFIBUS LED

①	Continuous light	PROFIBUS-DP communication is ok
②	Flashing	PROFIBUS-DP configuration or SmartWire configuration incorrect
③	OFF	No supply voltage available on the gateway or PROFIBUS-DP not connected

4 PROFIBUS-DP functions

Configuration of the DP master

Always perform the following steps for the configuration of the higher-level DP master.

- ▶ Append the corresponding GSD file and the bitmap in the GSD database of the configuration tool of your DP master to suit the CPU which you are using (→ section “GSD file”, page 32).
- Motorola based CPU (e.g. for Siemens S7):
 - Moel4d12.gsd,
 - KM4D12_N.bmp,
 - KM4D12_D.bmp.
- Intel based CPU (e.g. for Eaton XC100/200, PS4):
 - Moe4d12.gsd,
 - KM4D12_N.bmp,
 - KM4D12_D.bmp.
- ▶ Add the “SmartWire Gateway (S7/S5)” slave in the topology of the PROFIBUS segment to be configured. You will find the slave in the library under “Other field devices → Switchgear”.
- ▶ Assign this slave with the intended slave address.
- ▶ Select for this slave up to 16 of the suggested modules per SmartWire system for the cyclic data transfer, → section “Slave modules”, page 24.
- ▶ Repeat steps 2 to 4 for every SWIRE-GW-DP slave to be added to the topology.
- ▶ Save the configuration.
- ▶ Transfer the configuration to the DP master.



The monitoring time of the SmartWire slaves is fixed to 400 ms and cannot be changed.

Slave modules

The gateway SWIRE-GW-DP is a PROFIBUS-DP slave conform to IEC 61158.

In the PROFIBUS-DP configurator of the master control the following modules of the “SmartWire Gateway” slave can be used when the corresponding GSD file is used:

- Universal module (S7/S5),
- SWIRE-DIL module,
- SWIRE-4DI-2DO-R module.

The modules are described in detail in the following sections.

The PROFIBUS-DP reads and sends an octet of data per module in the SmartWire system. During a read operation bit 7 is used as a status bit.

Universal module



The universal module cannot be used as an empty slot in the SmartWire system. The slaves must be inserted without a gap.

SWIRE-DIL module

Table 4: Send data (write from the point of view of the PROFIBUS-DP)

SWIRE-DIL	Bit							
	7	6	5	4	3	2	1	0
Contactor actuation								0/1 ¹⁾

1) → table 5.

Table 5: Definition of the bit

0	Switch off contactor
1	Switch on contactor

Table 6: Receive data (read from the point of view of the PROFIBUS-DP)

SWIRE-DIL	Bit							
	7	6	5	4	3	2	1	0
Contactor status								0/1 ¹⁾
PKZ status							0/1 ¹⁾	
SWIRE-DIL status	0/1 ¹⁾							

1) → table 7.

Table 7: Definition of the bit

	Contactor status	PKZ status	SWIRE-DIL status
0	OFF	OFF	OK
1	ON	ON	Error

SWIRE-4DI-2DO-R module

Table 8: Send data (write from the point of view of the PROFIBUS-DP)

SWIRE-4DI-2DO-R	Bit							
	7	6	5	4	3	2	1	0
Actuation output Q1								0/1 ¹⁾
Actuation output Q2							0/1 ¹⁾	

1) → table 9.

Table 9: Definition of the bit

0	Switch off relay
1	Switch on relay

Table 10: Receive data (read from the point of view of the PROFIBUS-DP)

SWIRE-4DI-2DO-R	Bit							
	7	6	5	4	3	2	1	0
Status input I1								0/1 ¹⁾
Status input I2							0/1 ¹⁾	
Status input I3						0/1 ¹⁾		
Status input I4					0/1 ¹⁾			
SWIRE-4DI-2DO-R status	0/1 ¹⁾							

1) → table 11.

Table 11: Definition of the bit

	Status input	SWIRE-4DI-2DO-R status
0	Input 0	OK
1	Input 1	Error

Diagnostic data

Diagnostics via the SmartWire system is possible in three steps:

- As long as the SmartWire modules communicate with the gateway they send a status bit for every module to the PROFIBUS-DP master (→ section “Slave modules”, page 24).
- A module which has failed is indicated in the diagnostics of the PROFIBUS-DP.
- Even the failure of the entire PROFIBUS-DP gateway is displayed in the diagnostics.

The SWIRE-GW-DP provides additional diagnostics information in addition to the standardized DP standard diagnostics which appear in a DPV0 master of class 1 as “device-specific diagnostics” and in a DPV1 master as “status diagnostics”.

Diagnostics information format

Reading of the diagnostics is implemented directly via the DP diagnostics command or via the defined diagnostics byte of the PROFIBUS-DP master using the PROFIBUS-DP configuration. Observe the documentation of the master device here.

At least 11 octets are read as diagnostics. They contain the following information.

Table 12: Address position of the diagnostics information in a DPV0 or DPV1 master

Diagnostics position	Designation
Octet 1	
Bit 0	Station does not exist
Bit 1	Station not ready
Bit 2	Configuration error
Bit 3	Additional diagnostics information
Bit 4	Function not supported
Bit 5	Invalid DP slave response
Bit 6	Parameterization error
Bit 7	Master already present
Octet 2	
Bit 0	Parameterization request
Bit 1	Static diagnostics
Bit 2	Not used, always 1
Bit 3	Response monitoring activated
Bit 4	Freeze mode active
Bit 5	Sync mode active
Bit 6	Not used
Bit 7	Slave deactivated

Diagnostics position	Designation
Octet 3	
Bit 0...6	Not used
Bit 7	Overflow of additional diagnostics information
Octet 4	DP master station address
Octets 5 and 6	Ident no. DP slave: 4D12
Octet 7	Length of additional diagnostics information
Octet 8	Status Type: 130
Octet 9	Slot Number
Octet 10	Status Specifier
Octet 11	
Bit 0...1	Status SmartWire module 1
Bit 2...3	Status SmartWire module 2
Bit 4...5	Status SmartWire module 3
Bit 6...7	Status SmartWire module 4
Octet 12	
Bit 0...1	Status SmartWire module 5
Bit 2...3	Status SmartWire module 6
Bit 4...5	Status SmartWire module 7
Bit 6...7	Status SmartWire module 8
Octet 13	
Bit 0...1	Status SmartWire module 9
Bit 2...3	Status SmartWire module 10
Bit 4...5	Status SmartWire module 11
Bit 6...7	Status SmartWire module 12

Diagnosics position	Designation
Octet 14	
Bit 0...1	Status SmartWire module 13
Bit 2...3	Status SmartWire module 14
Bit 4...5	Status SmartWire module 15
Bit 6...7	Status SmartWire module 16

Meaning of the diagnostics information

The read diagnostics information has the following meaning:

Table 13: Data content of the diagnostics information

Designation	Meaning	Explanation/remedy
Response monitoring activated	The response monitoring in the SWIRE-GW-DP has been correctly activated.	Set state
Freeze mode active	The DP master has activated the synchronous reading of data inputs of several slaves.	Is not supported.
Function not supported	The DP master has requested one of the functions not supported by the SWIRE-GW-DP.	Check the configuration of the DP master
Ident no. DP slave	Contains the Ident no. of the SWIRE-GW-DP: 4D12 _{hex}	–
Configuration error	The DP master has sent an invalid configuration telegram to the SWIRE-GW-DP (e.g. incorrect length of the data inputs and/or data outputs)	Check the configuration of the DP master
Length of additional diagnostics information	Contains the length of the additional diagnostics information	–

Designation	Meaning	Explanation/remedy
Master already present	The SWIRE-GW-DP is occupied by another DP master.	–
Not used	Does not contain information to be evaluated	–
Parameterization request	The SWIRE-GW-DP waits for the parameterization telegram of the DP master.	Temporary state
Parameterization error	The DP master has sent an invalie parameteization telegram to the SWIRE-GW-DP.	Check the configuration of the DP master
Slave deactivated	The DP master has removed the SWIRE-GW-DP from its cyclic processing (deactivated).	Intended user action.
Slot Number	Contains the slot number, from which the additional diagnostics information (status) originates: 00 _{hex}	–
Station not ready	The SWIRE-GW-DP is not yet ready for communication (initialization phase).	Temporary state
Station does not exist	No slave responds at the station address used.	Check the configuration of the DP master
DP master station address	Contains the station address of the DP master.	–
Static diagnostics	The communication between SWIRE-GW-DP and the SmartWire modules is interrupted.	Checking of the SmartWire connections.
Status SmartWire modules 1...16	Describes the validity of the received data of the SmartWire modules, bit combinations (→ table 14, page 31)	–

Designation	Meaning	Explanation/remedy
Status Specifier	The SWIRE-GW-DP provides no "incoming/outgoing" signal for the sent diagnostics information (Status): 00 _{hex}	–
Status type	The SWIRE-GW-DP uses the status type "status message": 01 _{hex}	–
Sync mode active	The DP master has activated the synchronous output of data outputs to several slaves.	Is not supported.
Overflow of additional diagnostics information	The additional diagnostics data (status) are greater than the memory space reserved for it in the DP master.	Check the configuration of the DP master
Invalid DP slave response	The SWIRE-GW-DP has sent an invalid password.	Check the cabling and the interference prevention measures.
Additional diagnostics information	The SWIRE-GW-DP has sent additional diagnostics information (status).	Set state

The following bit combinations for the status of the SmartWire modules can occur:

Table 14: Meaning of the bit combinations

Bit combination	Validity	Meaning
00	Data valid	Module OK or module not engineered
01	Data invalid	Module error
10	Data invalid	Incorrect module
11	Data invalid	Module not available

GSD file

For selection of the device and the operation on the PROFIBUS-DP fieldbus a device master file (GSD file) is required. The GSD file contains common PROFIBUS slave descriptions. Two different GSD files exist for the SmartWire system:

- Motorola based CPU (e.g. for Siemens S7):
Moel4d12.gsd,
- Intel based CPU (e.g. for Eaton XC100/200, PS4):
Moe4d12.gsd

Two bitmaps are also available:

- KM4D12_N.bmp,
- KM4D12_D.bmp.

You can access these files at the following Internet address:

<http://www.moeller.net/en/support/index.jsp>

Follow the links on these pages.

Fault-finding

In addition to the diagnostic messages in the PROFIBUS-DP (→ section “Diagnostic data”, page 26) the LEDs on the SmartWire modules and on the PROFIBUS-DP gateway can be used to trace the fault.

Table 15: Error messages

No.	Part	Event	Explanation	Remedy
1	Gateway	SmartWire LED flashing	Configuration of the unit is not correct	<ul style="list-style-type: none"> • Check plug connection • Press configuration button after exchange of device
	SWIRE-DIL or SWIRE-4DI-2DO-R	Ready LED flashing		
	Follwomng SmartWire modules	Ready LED pulse flashing		
2	Gateway	Ready-LED OFF	Internal error	Exchange gateway
		PROFIBUS LED ON or flashing		
3	Gateway	Ready LED flashing	No PROFIBUS-DP communication available	Check the PROFIBUS-DP connection
		PROFIBUS LED OFF		
4	Gateway	Ready LED flashing	PLC in STOP	Switch PLC to RUN
		PROFIBUS LED ON		
5	Gateway	Ready LED flashing	PROFIBUS-DP configuration or SmartWire configuration incorrect	Check configurations
		PROFIBUS LED flashing		
6	Gateway	U-Aux-LED OFF	No voltage on the U-Aux terminal	Check the power supply, wiring and fusing for the supply voltage to the contactor coils

Appendix

Technical Data	General	
Standards and regulations		
General		IEC/EN 60947, EN 55011, EN 55022 IEC/EN 61000-4, IEC/EN 60068-2-27
PROFIBUS-DP		IEC 61158
Mounting		Top-hat rail IEC/EN 60715 (35 mm)
Dimensions (W × H × D)	mm	35 × 90 × 109
Weight	kg	0.15
Terminal capacity		
Solid	mm ²	0.5 - 1.5
Flexible with ferrule	mm ²	0.5 - 1.5
Solid or stranded	AWG	22 - 16
Standard screwdriver	mm	3.5 × 0.8
Max. tightening torque	Nm	0.6

Environmental conditions

Ambient climatic conditions		
Ambient temperature		
Operation	°C	-25 - +55
Storage	°C	-25 - +70
Condensation		Prevent condensation with suitable measures
Relative humidity, non-condensing (IEC/EN 60068-2-30)		%
		5 - 95
Air pressure (in operation)		hPa
		795 - 1080
Ambient mechanical conditions		
Degree of protection (IEC/EN 60529)		IP20
Pollution degree		2
Mounting position		Vertical

Electromagnetic compatibility (EMC)

Electromagnetic compatibility (EMC)			
Electrostatic discharge (IEC/EN 61000-4-2, Level 3, ESD)			
Air discharge		kV	8
Contact discharge		kV	6
Electromagnetic fields (IEC/EN 61000-4-3, RFI)	V/m		10
Radio interference suppression (EN 55011, EN 55022)			Class A
Burst Impulse (IEC/EN 61000-4-4, Level 3)			
Power cables		kV	2
Signal cables		kV	2
High-energy pulses (surge) (IEC/EN 61000-4-5, Level 2)		kV	0.5 (supply cables, symmetrical)
Line-conducted interference (IEC/EN 61000-4-6)		V	10

Dielectric strength

Dielectric strength			
Clearance in air and creepage distances			EN 50178, EN 60947-1, UL 508, CSA C22.2 No 142
Dielectric strength			EN 50178, EN 60947-1

Power supply voltages

Voltage supply, Gateway electronic and Smart-Wire station electronics U_{Gateway}		
Rated operating voltage U_{Gateway}	V DC	24, -15 %, +20 %
Admissible range		20.4 - 28.8
Residual ripple	%	≤ 5
Maximum current consumption at 24 V DC	mA	350 (typically 110 gateway + typically 15 per SmartWire module)
Voltage dips (IEC/EN 61131-2)	ms	10
Heat dissipation at 24 V DC	W	Normally 6
Protection against polarity reversal		Yes
Short-circuit protection SmartWire side		Yes
Power supply U_{AUX} (power supply for switching SmartWire elements e.g. contactor coils)		
Rated operational voltage U_{AUX}	V DC	24, -15 %, +20 % (Derating from > 40 °C)
Admissible range	V DC	20.4...28.8, at 45 °C: 21- 28.8, at 50 °C: 21.6 - 28.8, at 55 °C: 2 - 27.6
Input current U_{AUX} at 24 V DC	A	Normally 3
Residual ripple	%	≤ 5
Voltage dips (IEC/EN 61131-2)	ms	10
Protection against polarity reversal		Yes
Short-circuit protection SmartWire side		No, external fuse 3 A or FAZ-Z3 necessary

LED displays

LED displays		
Ready for operation		Ready: green
Power supply SmartWire contactors		U_{AUX} : green
Status PROFIBUS-DP		PROFIBUS-DP: green
Status SmartWire		SmartWire: green

PROFIBUS-DP

PROFIBUS-DP		
Connection types		SUB-D 9 pole, socket
Station address		1 - 125
Address allocation		DIP switch
Electrical isolation		
for supply voltage U_{AUX}		Yes
for supply voltage $U_{Gateway}$		Yes
To SmartWire		Yes
Function		PROFIBUS-DP slave
Bus protocol		PROFIBUS-DP
Bus terminating resistors		Can be connected via plug
Transfer rate		automatically to 12 Mbit/s

SmartWire system

SmartWire		
Connection types		Plug, 6-pole
Data/power cable		6 core flat-band cable
maximum cable length, SmartWire system	m	Max. 4
Bus termination		No
Station address		Automatic assignment
Station		Max. 16
Address allocation		None
Electrical isolation		
for supply voltage U_{AUX}		No
for supply voltage $U_{Gateway}$		No

Dimensions

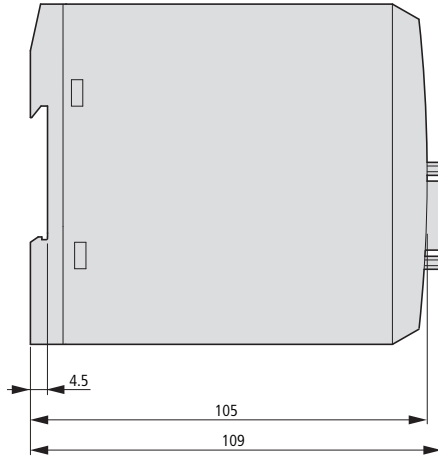
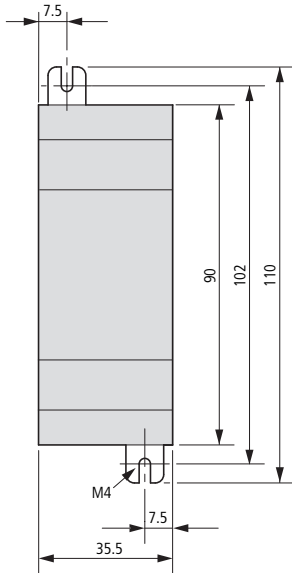

Index

B	Baud rate	16
C	Configuration	20
	Configuration button	6, 19
	Connect	
	SmartWire connection cable	10
	Connection	
	PROFIBUS-DP	12
	Supply voltages	11
	Connection cable	
	SmartWire	10
D	Diagnostics messages	26
	DIP switch	9
E	EMC measures	14
	Error messages	33
G	GSD file	23, 32
L	LEDs	
	Error messages	33
	Meaning	20
M	Master	5
	Monitoring time	23
P	Potential separations	15
	PROFIBUS-DP	
	Connection	12

R	Read	7
----------	------------	---

S	Set station address	9
	Shielding, network cable	15
	Slave	5
	Slave modules	24
	SmartWire	
	Connection cable	10
	I/O module	6
	Module for DILM	6
	Rung	6
	Standards	35
	Station address	9
	Status LEDs	20
	SUB-D	
	Plug	12
	Socket	12
	SWIRE-4DI-2DO-R	
	Receive data	26
	Send data	25
	SWIRE-DIL	
	Receive data	25
	Send data	24
	Switch on and off of terminating resistor	14
	Switch on, initial	19
	Switching states feedback	7

T	Transfer rate	16
----------	---------------------	----

W	Write	7
----------	-------------	---