

# The Interaction of Contactors with PLCs

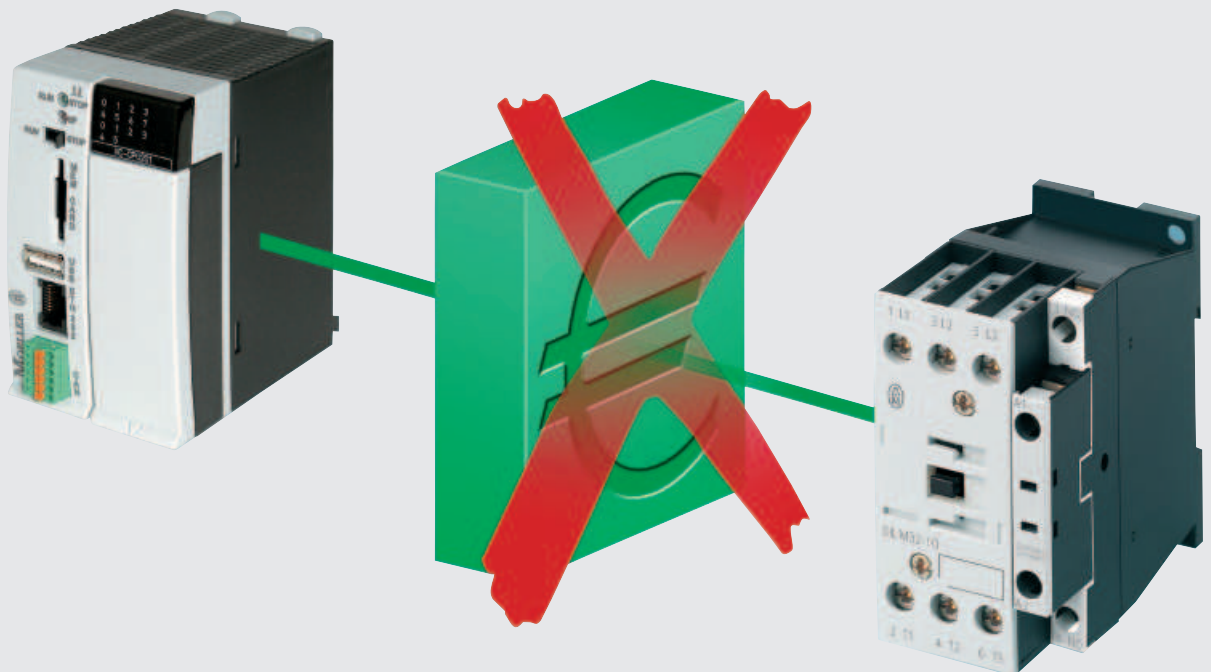

Technical Paper  
Dipl.-Ing. Wolfgang Nitschky

# Design and function of the DC operated contactors DILM7 to DILM170

The market for DC operated contactors continues to grow because of the advances in electronics manufacturing. Whereas 20 years ago AC operated contactors were fitted with additional resistors, and only recently special DC coils incorporating lots of copper were wound, the next quantum jump has been undertaken with the introduction of electronics in the magnet systems of DC operated contactors.

The Xstart contactor series DIL M7 to DIL M170 has been optimised in particular during development to DC

operated contactors. The DC operated contactors DIL M17 to DIL M170 are no longer switched on and off in the conventional manner via a coil, but rather the coil is controlled by electronics.

[1] The electronic actuation features protection against polarity reversal which is used to supply the control voltage of the electronic control. Here the protection against polarity reversal will protect the contactor electronics from incorrect connection of the control voltage. The contactor will remain switched off in this case. Following the protection against

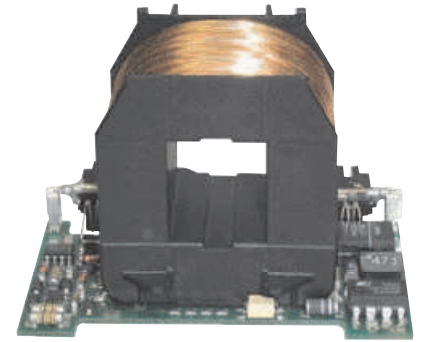
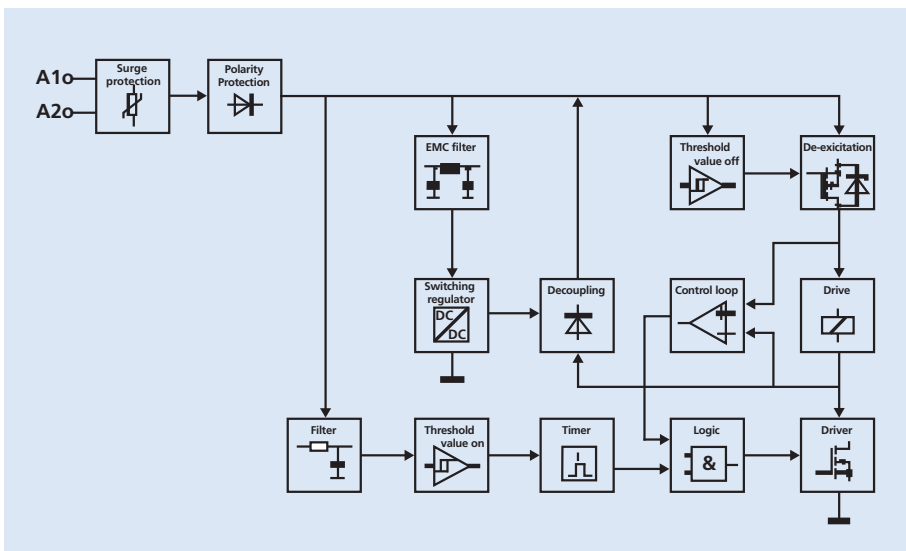

**Figure 2: Electronic contactor magnet system**

polarity reversal a filter circuit as well as a threshold trigger will regulate the level of the control voltage. Only after a minimum level for safe switch-on is achieved will a timer be triggered, which controls a driver for a defined switch on time and which thus initiates the switch on process of the magnetic drive.

The driver is switched off after the set make time has timed out. The power supply to the magnet system coil is now undertaken using a DC/DC converter which provides a constant supply voltage that is about 10 % of the magnitude of the rated voltage.

If there is an undershoot of the shut off threshold, the energization circuit is activated and the drive is de-energized via a defined freewheeling voltage. Based on the configuration of this circuit the break time of the contactor is on the one hand very constant and on the other fully independent of the mains power factors as well as the external circuitry. In conjunction with protection against polarity reversal the shutdown of a contactor has no negative effects on the power supply. Therefore an external suppressor circuit is not required.



**Figure 1: Electronic contactor circuit block diagram**

## Technical characteristics of the DC operated contactors with integrated electronics and their advantages in engineering

The integration of electronics in the contactor magnetic system makes various technical features possible which distinguish the contactor in its day to day use.

### Wide voltage range coils

The DC operated contactors DIL M17 – DIL M170 cover the complete DC control voltage range with just 4 control voltage variants.

Rated actuating voltage:	
RDC24	24 - 27 VDC
RDC60	48 - 60 VDC
RDC130	110 - 130 VDC
RDC240	200 - 240 VDC

**Table 1: Rated actuating voltage range**

Voltage tolerance:	
RDC24	17 - 32 VDC
RDC60	34 - 72 VDC
RDC130	77 - 156 VDC
RDC240	140 - 288 VDC

**Table 2: Range of the voltage tolerance**

### Voltage tolerance

Contactors are designed in compliance to the IEC/EN 60947-4-1 [2] standard. In order to guarantee operating security even with small deviations in the power supply, this demands safe switch on of the contactor in a range from 85 % to

ply. An additional suppressor is therefore unnecessary as the coils do not generate any external overvoltages.

All other DC operated contactors from Eaton Moeller feature an integrated suppressor circuit. All in all the issue of over-voltage protection in control circuits is no longer a problem when engineering DC operated contactors from Eaton Moeller, as all DC operated contactors are free of interaction with the power supply.

### Contactor dimensions

The electronics provide the coil with a high switch on power for switching on

spondingly high power is provided which enables the contactor to safely switch. A very low power is required in order to retain the contactors state. The electronics only provide this power.

The minimised holding powers mean a significant reduction in the heat development in the control panel in the engineering phase. This allows side-by-side installation of the devices in the control panel.

### Control of the contactors directly by the PLC's

A typical application for DC operated contactors is the direct control from the PLC. Hereby a semiconductor output of the contactor is supplied directly with the control voltage. Typical semiconductor outputs of PLC's provide a power of 500 mA at 24 V. Contactors up to 32 A can be operated directly by a semiconductor output of this type without the need for additional coupler relays.

The engineering costs of DC power supplies can be reduced by the use of electronics. The power supply no longer needs to be engineered as with conventional contactor coils according to the sum of the pick-up powers. The power supply is engineered according to the following considerations: The sum of the switch-on powers of all contactors which pick-up simultaneously are added to the sum of all holding powers of all contactors which are switched on simultaneously. As the holding powers are very low the power supply can be significantly smaller.

### Comparison of the holding powers with the competitors

In direct comparison with the holding powers of DC operated contactors from 4 to 75 kW (Figure 4), it becomes apparent that the new Xstart series sets new standards on the market. The holding power of the contactors with integrated electronics is considerably less than all of the competitors.

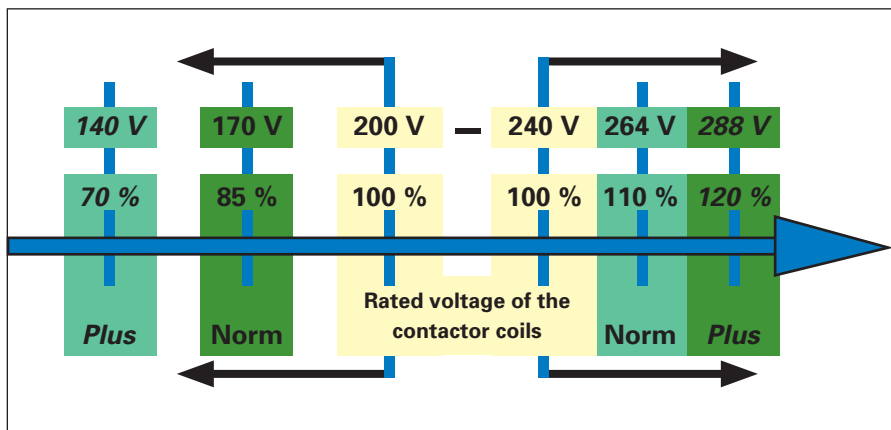

**Figure 3: Representation of voltage tolerance**

110 % of the rated actuating voltage. The DC operated contactors DIL M17 – DIL M170 feature an even wider range in which the contactors switch reliably. This enables safe operation between (0.7 x U<sub>cmin</sub>) and (1.2 x U<sub>cmax</sub>) of the rated actuating voltage.

### Integrated suppressor circuit

Conventionally controlled contactors generate voltage peaks on the coil due to the di/dt change in the current which can have negative effects on the other components in the same control circuit. In order to avoid damage, suppressor coils are frequently connected in parallel with additional suppressor circuits (RC networks, varistors or diodes).

The DC operated contactors DIL M17 – DIL M170 switch off without noninteraction with the power supply (I Design and function of the DC operated contactors DILM7 to DILM170). The large contactors DIL M185 – DIL H2000 are also controlled accordingly via electronics and are also free of interaction with the power sup-

the contactor and reduces this after the switch on process has been completed to the required holding power. This makes it possible to implement AC operated and DC operated contactors of the same dimensions. When engineering AC and DC operated contactors consideration of the different mounting depths is no longer an issue.

### Pick-up and holding power

The electronics with the DC operated contactors DIL M17 – DIL M170 controls the switch on process of the contactors. For pick-up of the contactor a corre-

Motor rating AC-3 at 400 V	Contactor type	Pick-up power	Holding power
7.5 - 15 kW	DILM17 - DILM32	12 W	0.5 W
18.5 - 37 kW	DILM40 - DILM72	24 W	0.5 W
37 - 45 kW	DILM80 - DILM95	90 W	1.3 W
55 - 90 kW	DILM115 - DILM170	149 W	2.1 W

**Table 3: Overview of the pick-up and holding powers for the new DC operated contactor series**

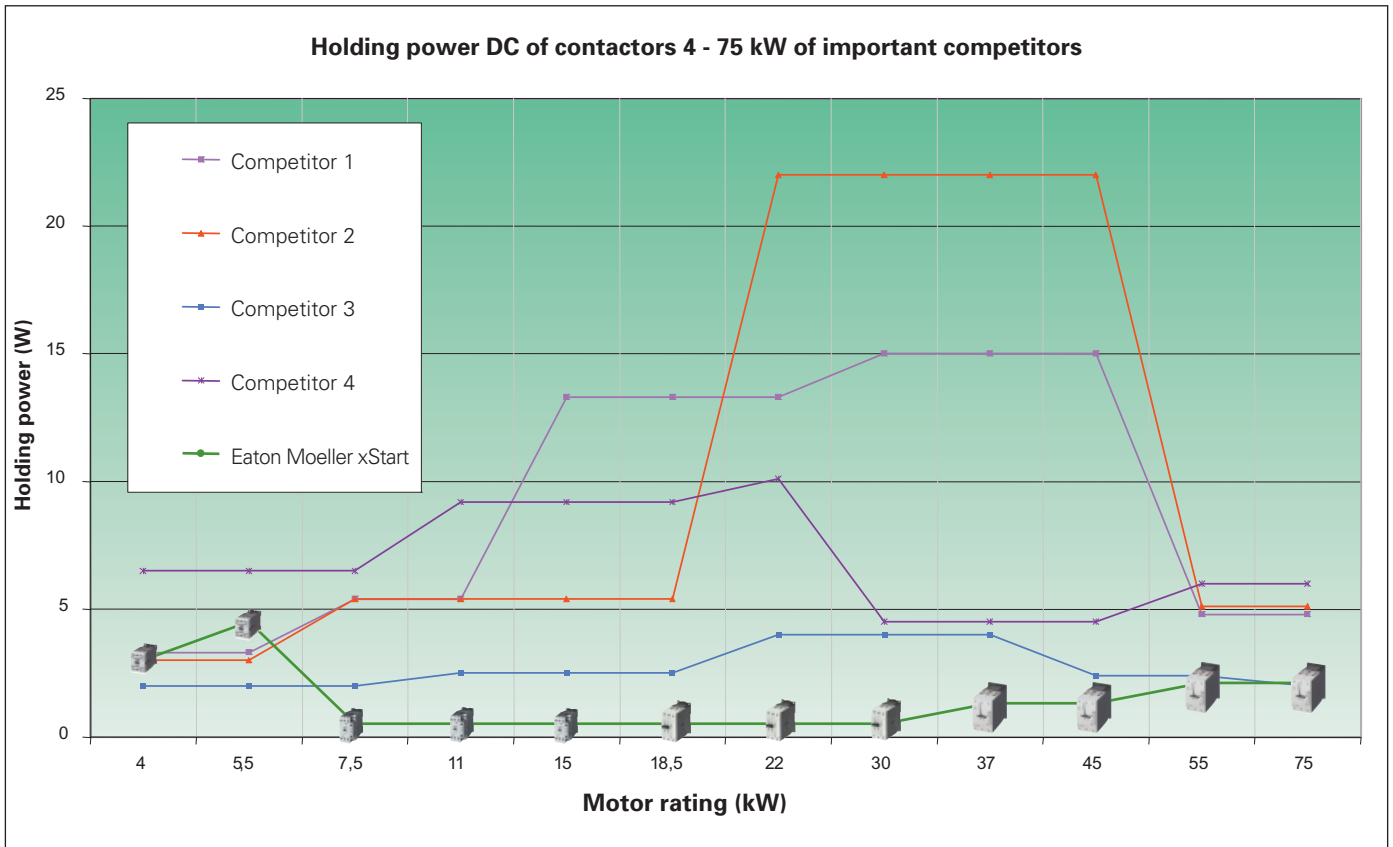

Figure 4: Comparison of the holding power for DC operated contactors from 4 - 75 kW

### Combination with PLC's

The direct control of contactor coils from the PLC reduces the costs for coupler relays and reduces the wiring effort involved. For this the output must provide both the pick-up and the holding power for the contactor coils. PLC's with different outputs are available on the market. In addition to expensive relay outputs, there are also semi-conductor outputs with different output currents available. Typically the semi-conductor outputs are offered with 0.1 A or 0.5 A, and the most common are the semi-conductor outputs with 500 mA. Table 4 provides an overview of the output required to control the corresponding contactor. For control with 100 mA outputs Eaton Moeller provides a special interface solution DIL M7-SOND516 to DIL M12- SOND516.

Output power on transistor output	100 mA	500 mA
DIL M7-SOND516 - DIL M12-SOND516	•	•
DIL M7 - DIL M15	–	•
DIL M17 - DIL M32	–	•
DIL M40 - DIL M72	–	–

Table 4: Control of the Xstart contactors from the PLC's

### Combination with safe PLC's

#### Monitoring function of safe PLC outputs

A significant difference between PLC's for control of normal operational functions and safe PLC's is the cyclic monitoring of the PLC outputs in safety PLC's. Typically the outputs of master drives are controlled and cyclically briefly interrupted in safety PLC's. The interruption is in the order of just 10 - 50 ms, so that the connected actuators (contactors, valves) do not shut off. During the interruption it is monitored if the output voltage drops below a defined level. If this is not the case the PLC detects a defective output and switches off. A capacitive connection of the outputs dampens the drop of the voltage so that some manufacturers stipulate a maximum permissible capacitance on the safe outputs.

Furthermore, the outputs are monitored for negative voltages.

#### Combinations

The contactors DIL M7 to DIL M15 contactors are controlled by conventional coils with varistor protective circuitry. They generate a negative voltage on terminals A1 – A2 during switch off.

	Permissible output capacitance's
Siemens	20nF
Pilz	5nF
Jokab Saftey	not available

Table 5: Permissible capacitance's on safe PLC outputs

This is reliably prevented with an additional diode suppressor DIL M12-XSPD. Contactors DIL M7 to DIL M15, which feature diode suppressors operate reliably with all safe semi-conductor outputs of the conventional safety PLC's available.

The magnet system of the contactors DIL M17 to DIL M32 are controlled by electronics. In order to protect the electronics against EMC the input on the PCB is protected against polarity reversal by a varistor which always represents a capacitive load. The coil input of the contactors DIL M17 to DIL M32 features a capacitive load of 5 nF. These contactors have been tested in combination with the safety PLC's from Pilz, Siemens and Jokab Saftey. Contactors DIL M17 to DIL M32 from manufacturing code 3106 and more recent devices operate perfectly with PLC's.

## Feedback in the PLC

In addition to direct control of the contactors from the PLC a feedback to the system concerning the state of the contactor is also generally required. This is generally possible with every contactor auxiliary contact. Eaton Moeller provides an electronic auxiliary contact DIL M32-XHIR11 specially optimised for smaller currents and voltages. This is suitable for currents of 1 mA at 5 V. The enhanced contact reliability ensures reliable feedback even in unfavourable environmental conditions, e.g. dusty atmosphere's.

In combination with safety applications the state of the contactor must be fed back correctly even during a fault. Auxil-

iary NC contacts which are rated as mirror contacts are used for this purpose. All auxiliary contacts of the Eaton Moeller contactor series DIL M and DIL A are approved as mirror contacts. Even the electronic auxiliary switch is approved as a mirror contact and ideal for the combination with safety PLC's.

## Summary

The new Xstart contactors DIL M17 to DIL M170 with DC operation excel due to their integrated electronics in the contactor magnet system. Because of the considerable reduction of the heat dissipation they enable direct actuation of the contactors DIL M7 to DIL M32 with a

PLC semi-conductor output without coupler relays. The control by a safety PLC with monitored outputs has also been tested. The new electronic auxiliary contact provides reliable feedback to the PLC and is also suitable as a mirror contact for safety applications.

Author:  
Dipl.-Wirt. Ing.  
Wolfgang Nitschky  
Product Support Switching & Protection  
Devices  
Eaton Industries GmbH, Bonn

## Literature

- [1] Wilhelm Melchert and Gerd Schmitz  
Electronic contactor control  
Moeller GmbH 2004
- [2] IEC/EN 60947-4-1: 2004-04,  
Low-voltage switchgear and controlgear – Part 4-1:  
Contactors and motor-starters;  
Electromechanical contactors and motor-starters

<b>Mirror contacts to IEC EN 697-4-1 Annex F</b>		
	<b>Integrated auxiliary contact<sup>1)</sup></b>	<b>Auxiliary break contact<sup>1)</sup> in additional auxiliary contact module</b>
DIL EM-10	No auxiliary break contact available	yes
DIL EM-01	yes	yes
DIL M7-10 - DIL M15-10	No auxiliary break contact available	yes
DIL M7-01 - DIL M15-01	yes	yes
DIL M17-10 - DIL M32-10	No auxiliary break contact available	yes
DIL M17-01 - DIL M32-01	yes	yes
DIL M40 - DIL M72	No auxiliary break contact available	yes
DIL M80 - DIL M170	No auxiliary break contact available	yes
DIL M185/22 - DIL M250/22	yes	yes
DIL M300/22 - DIL M500/22	yes	yes
DIL M580/22 - DIL M1000/22	yes	yes

<sup>1)</sup> does not apply for late-break contacts

**Table 6: Mirror contacts with Moeller contactors**

<b>Advantages of the xStart contactor series in combination with PLCs</b>	
Contactors with wide voltage range coils	Simplifies engineering
The enhanced voltage tolerance of the contactor coils	Guarantees reliable operation even in less stable power supply networks
Integrated suppressor circuit in the DC operated contactors	Provides protection for electronic components
Identical dimensions with AC and DC operated contactors	Simplifies engineering
Reduced heat dissipation of the contactors coils	Improves the heat balance in the control panel, saves coupling relays as the contactors can be directly actuated, reduces costs for the power supply as a smaller power supply is required
Tested combinations of contactors and safety PLC	Offers a high level of functional safety
Electronic auxiliary contact	Enables reliable feedback with small signal levels
Auxiliary contact with mirror contact function	Reliably signals the position of the main contactor contacts

**Table 7: Advantages of the interaction of Xstart contactors with PLCs**

## **Eaton Corporation**

Eaton is a leading power management company. Eaton operates worldwide with products, systems and services in the electrical, hydraulic, aerospace, truck and automotive sectors.

## **Eatons Electrical Sector**

Eatons Electrical Sector is the worldwide leader in products, systems and services for energy distribution, safe electricity supply and automation in industrial, residential and purpose-built buildings, public facilities, energy providers, commerce and OEMs.

Eaton Electrical Sector includes the brands Cutler-Hammer®, Moeller®, Micro Innovation, Powerware®, Holec®, MEM® and Santak®.

**[www.eaton.com](http://www.eaton.com)**

**E-Mail:** [info-int@eaton.com](mailto:info-int@eaton.com)  
**Internet:** [www.eaton.com/moellerproducts](http://www.eaton.com/moellerproducts)

Publisher:  
Eaton Corporation  
Electrical Sector – EMEA

Eaton Industries GmbH  
Hein-Moeller-Str. 7-11  
D-53115 Bonn

© 2010 by Eaton Industries GmbH  
Subject to alterations  
VER2100-957GB ip 03/11  
Printed in Germany (03/11)  
Article No.: ??????