

Temposonics®

Magnetostrictive Linear Position Sensors

TH CANbus Data Sheet

- ATEX / IECEx / CEC / NEC / EAC Ex certified / Japanese approval
- Continuous operation under harsh industrial conditions
- Flameproof / Explosionproof / Increased safety



MEASURING TECHNOLOGY

The absolute, linear position sensors provided by MTS Sensors rely on the company's proprietary Temposonics® magnetostrictive technology, which can determine position with a high level of precision and robustness. Each Temposonics® position sensor consists of a ferromagnetic waveguide, a position magnet, a strain pulse converter and supporting electronics. The magnet, connected to the object in motion in the application, generates a magnetic field at its location on the waveguide. A short current pulse is applied to the waveguide. This creates a momentary radial magnetic field and torsional strain on the waveguide. The momentary interaction of the magnetic fields releases a torsional strain pulse that propagates the length of the waveguide. When the ultrasonic wave reaches the end of the waveguide it is converted into an electrical signal. Since the speed of the ultrasonic wave in the waveguide is precisely known, the time required to receive the return signal can be converted into a linear position measurement with both high accuracy and repeatability.

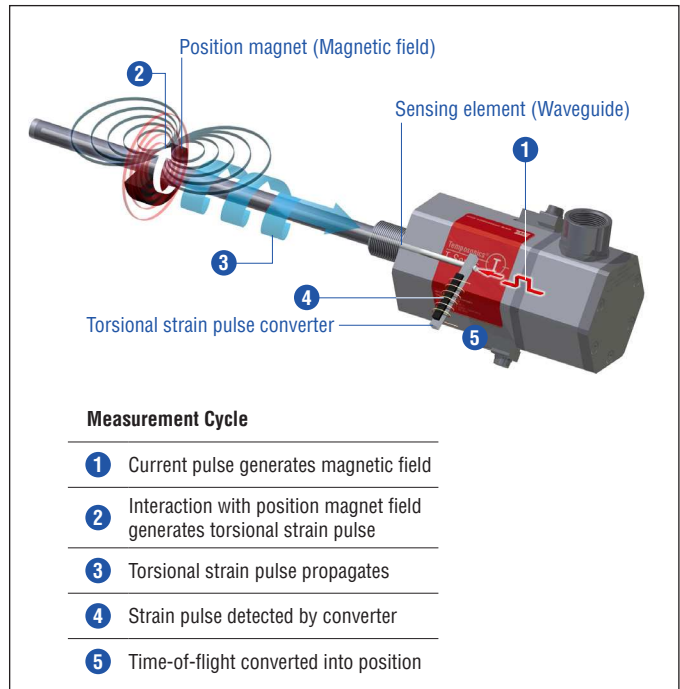

Fig. 1: Time-of-flight based magnetostrictive position sensing principle

TH SENSOR



Robust, non-contact and wear free, the Temposonics® linear position sensors provide best durability and accurate position measurement solutions in harsh industrial environments. The position measurement accuracy is tightly controlled by the quality of the waveguide which is manufactured by MTS Sensors. The position magnet is mounted on the moving machine part and travels contactlessly over the sensor rod with the built-in waveguide.

The TH sensor is extremely robust and ideal for continuous operation under harsh industrial conditions. T-Series sensors are certified for hazardous areas in Zone 0/1, Zone 1, Zone 2, Zone 21 and Zone 22 for Europe (ATEX), the global (IECEX), the Russian (EAC Ex) and the Japanese market, as well as for use in Class I, II, III, Division 1, Division 2 for Canada (CEC) and USA (NEC). The sensor electronics housing contains the active signal conditioning and a complete integrated electronics interface. The sensor rod is capable of withstanding high pressures such as those found in hydraulic cylinders. Furthermore the sensor is also suitable for petro chemical plants and caustic environments.



Fig. 2: Typical application: Tank systems

TECHNICAL DATA

Output																					
Interface	CAN-Fieldbus System according to ISO 11898																				
Data protocol	Corresponds to encoder profile DS 406 V3.1 (CiA Standard DS 301 V3.0)																				
Baud rate, kBit/s	1000 800 500 250 125 50 20																				
Cable length, m	< 25 < 50 < 100 < 250 < 500 < 1000 < 2500 The sensor will be supplied with ordered baud rate, which is changeable by customer																				
Measured value	Position / option: Multi-position measurement (2...4 positions)																				
Measurement parameters																					
Resolution	2 µm, 5 µm; velocity step size: See following table																				
	<table border="1"> <thead> <tr> <th rowspan="2">For stroke lengths</th> <th rowspan="2">having a cycle time of</th> <th rowspan="2">results in the following velocity step size</th> <th colspan="2">Velocity step size</th> </tr> <tr> <th>at 5 µm position resolution</th> <th>at 2 µm position resolution</th> </tr> </thead> <tbody> <tr> <td>Up to 2400 mm</td> <td>1.0 ms</td> <td rowspan="3">  </td> <td>0.5 mm/s</td> <td>0.2 mm/s</td> </tr> <tr> <td>Up to 4800 mm</td> <td>2.0 ms</td> <td>0.25 mm/s</td> <td>0.1 mm/s</td> </tr> <tr> <td>Up to 7620 mm</td> <td>4.0 ms</td> <td>0.125 mm/s</td> <td>0.05 mm/s</td> </tr> </tbody> </table>	For stroke lengths	having a cycle time of	results in the following velocity step size	Velocity step size		at 5 µm position resolution	at 2 µm position resolution	Up to 2400 mm	1.0 ms		0.5 mm/s	0.2 mm/s	Up to 4800 mm	2.0 ms	0.25 mm/s	0.1 mm/s	Up to 7620 mm	4.0 ms	0.125 mm/s	0.05 mm/s
For stroke lengths	having a cycle time of				results in the following velocity step size	Velocity step size															
		at 5 µm position resolution	at 2 µm position resolution																		
Up to 2400 mm	1.0 ms		0.5 mm/s	0.2 mm/s																	
Up to 4800 mm	2.0 ms		0.25 mm/s	0.1 mm/s																	
Up to 7620 mm	4.0 ms		0.125 mm/s	0.05 mm/s																	
Cycle time	1.0 ms up to 2400 mm stroke length 2.0 ms up to 4800 mm stroke length 4.0 ms up to 7620 mm stroke length																				
Linearity ¹	< ±0.01 % F.S. (minimum ±40 µm)																				
Repeatability	< ±0.001 % F.S. (minimum ±2.5 µm) typical																				
Hysteresis	< 4 µm typical																				
Temperature coefficient	< 15 ppm/K typical																				
Operating conditions																					
Operating temperature	-40...+75 °C (-40...+167 °F)																				
Humidity	90 % relative humidity, no condensation																				
Ingress protection	Version D, G and E: IP66 / IP67 (if properly connected by means that support IP66 / IP67 (pipe, gland, etc.)) Version N: IP66, IP67, IP68, IP69K, NEMA 4X, depending on cable gland																				
Shock test	100 g (single shock), IEC standard 60068-2-27																				
Vibration test	15 g / 10...2000 Hz, IEC standard 60068-2-6 (resonance frequencies excluded)																				
EMC test	Electromagnetic emission according to EN 61000-6-3 Electromagnetic immunity according to EN 61000-6-2 The sensor meets the requirements of the EU directives and is marked with CE																				
Operating pressure	350 bar static (5076 psi static)																				
Magnet movement velocity ²	Any																				
Design / Material																					
Sensor electronics housing	Stainless steel 1.4305 (AISI 303); option: Stainless steel 1.4404 (AISI 316L)																				
Flange	See "Table 1: TH rod sensor threaded flange type references" on page 7																				
Sensor rod	Stainless steel 1.4306 (AISI 304L); option: Stainless steel 1.4404 (AISI 316L)																				
Stroke length	25...7620 mm (1...300 in.)																				

See next page for "Mechanical mounting"

1/ With position magnet # 201 542-2

2/ If there is contact between the moving magnet (including the magnet holder) and the sensor rod, make sure that the maximum speed of the moving magnet is ≤ 1 m/s (Safety requirement due to ESD [Electro Static Discharge])

Mechanical mounting	
Mounting position	Any
Mounting instruction	Please consult the technical drawings and the operation manual (document number: 551871)
Electrical connection	
Connection type	T-Series terminal
Operating voltage	+24 VDC (-15 / +20 %)
Ripple	$\leq 0.28 V_{pp}$
Current consumption	90 mA typical
Dielectric strength	700 VDC (DC ground to machine ground)
Polarity protection	Up to -30 VDC
Overvoltage protection	Up to 36 VDC

CERTIFICATIONS

Certification required	Version E	Version D	Version G	Version N
IECEX / ATEX (IECEX: Global market; ATEX: Europe)	Ex db eb IIC T4 Ga/Gb Ex tb IIIC T130°C Ga/Db Zone 0/1, Zone 21 -40 °C ≤ Ta ≤ 75 °C	Ex db IIC T4 Ga/Gb Ex tb IIIC T130°C Ga/Db Zone 0/1, Zone 21 -40 °C ≤ Ta ≤ 75 °C	Ex db IIC T4 Ga/Gb Ex tb IIIC T130°C Ga/Db Zone 0/1, Zone 21 -40 °C ≤ Ta ≤ 75 °C	No hazardous area approval
NEC (USA)	—	—	Explosionproof Class I Div. 1 Groups A, B, C, D T4 Class II/III Div. 1 Groups E, F, G T130°C -40 °C ≤ Ta ≤ 75 °C Flameproof Class I Zone 0/1 AEx d IIC T4 Class II/III Zone 21 AEx tb IIIC T130°C -40 °C ≤ Ta ≤ 75 °C	No hazardous area approval
CEC (Canada)	—	—	Explosionproof Class I Div. 1 Groups B, C, D T4 Class II/III Div. 1 Groups E, F, G T130°C -40 °C ≤ Ta ≤ 75 °C Flameproof Class I Zone 0/1 Ex d IIC T4 Ga/Gb Class II/III Zone 21 Ex tb IIIC T130°C Db -40 °C ≤ Ta ≤ 75 °C	No hazardous area approval
EAC Ex (Russian market)	Ga/Gb Ex db eb IIC T4 X Da/Db Ex tb IIIC T130°C X Zone 0/1, Zone 21 -40 °C ≤ Ta ≤ 75 °C	Ga/Gb Ex db IIC T4 X Da/Db Ex tb IIIC T130°C X Zone 0/1, Zone 21 -40 °C ≤ Ta ≤ 75 °C	Ga/Gb Ex db IIC T4 X Da/Db Ex tb IIIC T130°C X Zone 0/1, Zone 21 -40 °C ≤ Ta ≤ 75 °C	No hazardous area approval
Japanese approval	Ex d e IIC T4 Ga/Gb Ex t IIIC T130°C Db Zone 0/1, Zone 21 -40 °C ≤ Ta ≤ 75 °C	Ex d IIC T4 Ga/Gb Ex t IIIC T130°C Db Zone 0/1, Zone 21 -40 °C ≤ Ta ≤ 75 °C	Ex d IIC T4 Ga/Gb Ex t IIIC T130°C Db Zone 0/1, Zone 21 -40 °C ≤ Ta ≤ 75 °C	No hazardous area approval

Fig. 3: Certifications

TECHNICAL DRAWING

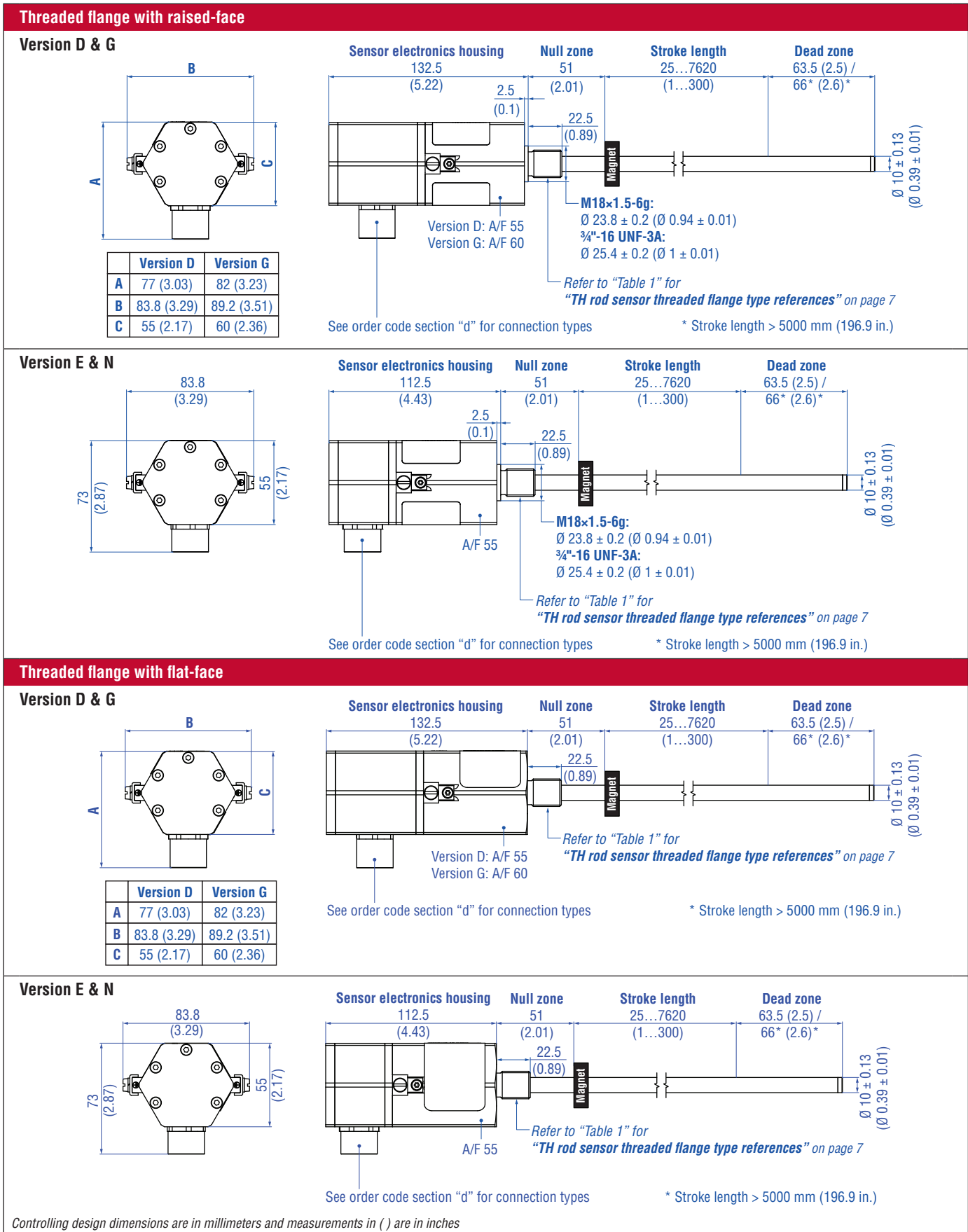

Fig. 4: Temposonics® TH with ring magnet

CONNECTION OPTIONS

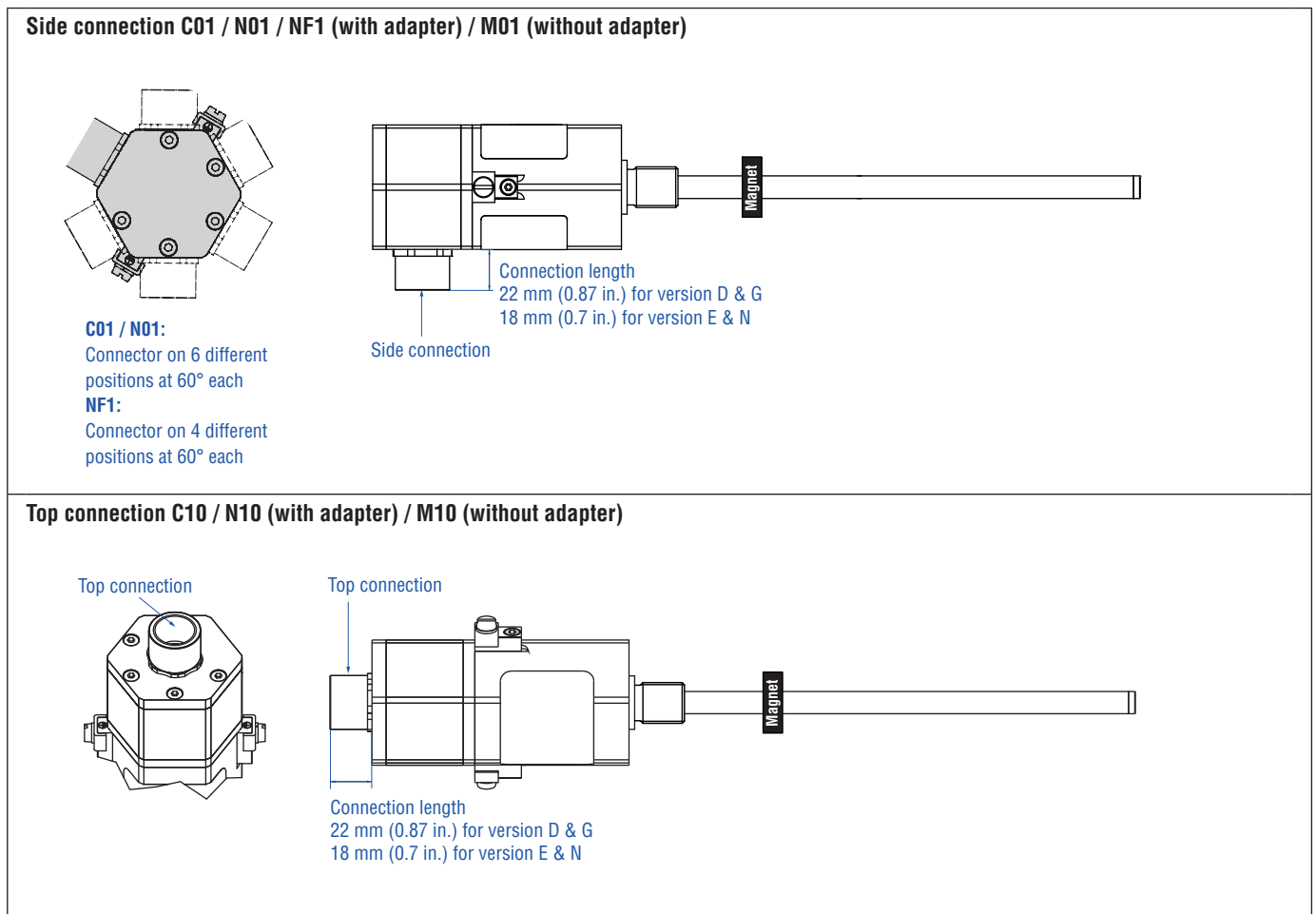

Fig. 5: Temposonics® TH connection options

Threaded flange type	Description	Threaded flange
F	Threaded flange with flat-face Stainless steel 1.4404 (AISI 316L)	¾"-16 UNF-3A
G	Threaded flange with raised-face Stainless steel 1.4404 (AISI 316L)	¾"-16 UNF-3A
M	Threaded flange with flat-face Stainless steel 1.4305 (AISI 303)	M18×1.5-6g
N	Threaded flange with raised-face Stainless steel 1.4305 (AISI 303)	M18×1.5-6g
S	Threaded flange with flat-face Stainless steel 1.4305 (AISI 303)	¾"-16 UNF-3A
T	Threaded flange with raised-face Stainless steel 1.4305 (AISI 303)	¾"-16 UNF-3A
W	Threaded flange with flat-face Stainless steel 1.4404 (AISI 316L)	M18×1.5-6g

Table 1: TH rod sensor threaded flange type references

ZONE CLASSIFICATION

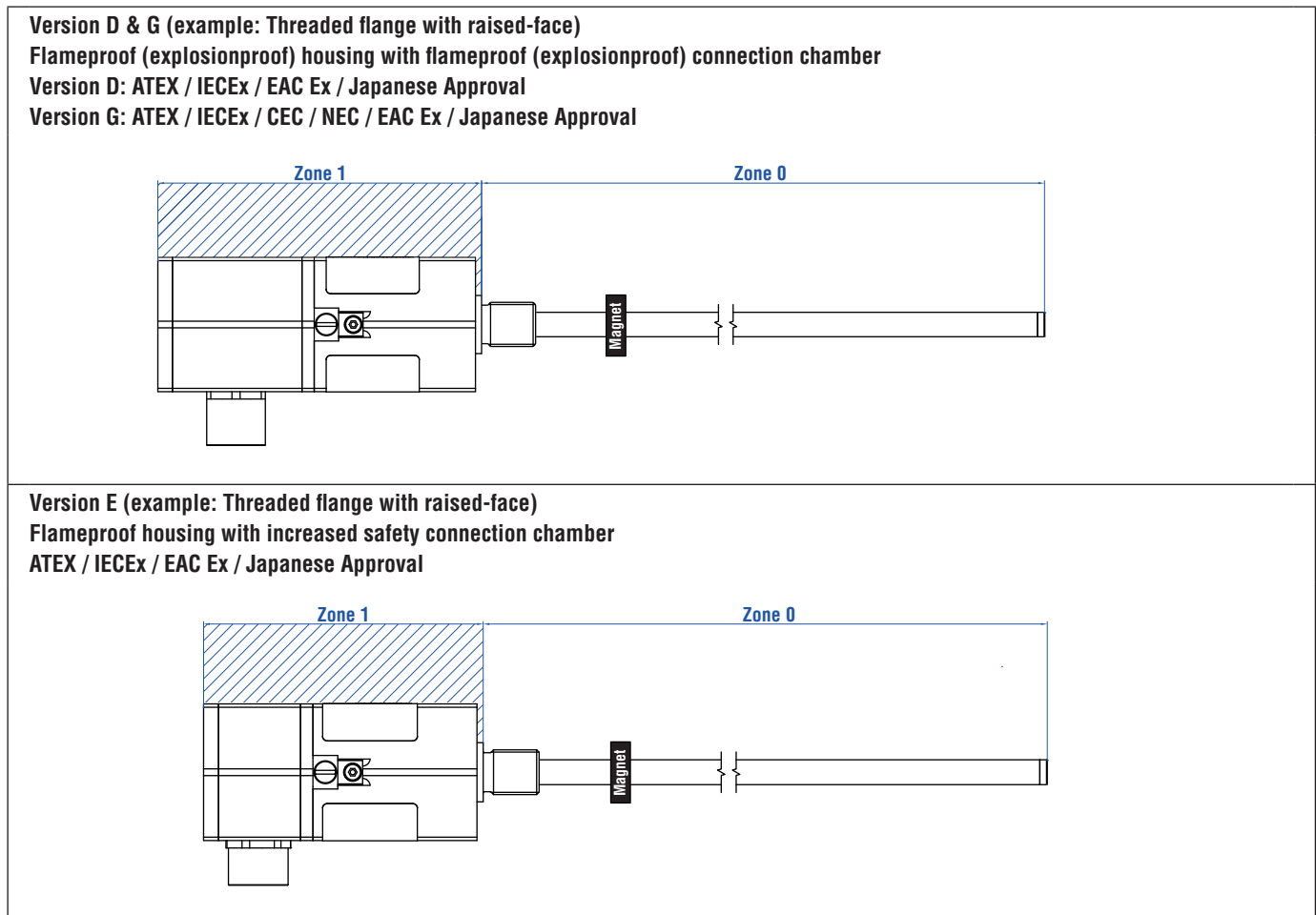

Fig. 6: Temposonics® TH Zone classification

NOTICE

Seal sensor according to ingress protection IP67 between Zone 0 and Zone 1.

CONNECTOR WIRING

Version D & G suitable for connection types: C01, C10, N01, N10		
Signal + power supply		
Terminal	Pin	Function
	1	CAN_L
	2	CAN_H
	3	Not connected
	4	Not connected
	5	+24 VDC (-15 / +20 %)
	6	DC Ground (0 V)
	7	Cable shield

Fig. 7: TH (version D & G) wiring diagram (2.5 mm² conductor)

Version E & N suitable for connection types: C01, C10, M01, M10, N01, N10		
Signal + power supply		
Terminal	Pin	Function
	1	CAN_L
	2	CAN_H
	3	Not connected
	4	Not connected
	5	+24 VDC (-15 / +20 %)
	6	DC Ground (0 V)
	7	Cable shield

Fig. 8: TH (version E & N) wiring diagram (1.5 mm² conductor)

Version E & N suitable for connection type: NF1		
Signal + power supply		
Terminal	Pin	Function
	1	CAN_L
	2	CAN_H
	3	Not connected
	4	+24 VDC (-15 / +20 %)
	5	DC Ground (0 V)
	6	Cable shield

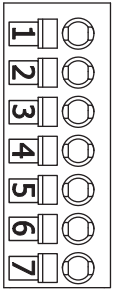
Fig. 9: TH (version E & N) wiring diagram (2.5 mm² conductor)

FREQUENTLY ORDERED ACCESSORIES – Additional options available in our [Accessories Guide](#)  [551444](#)

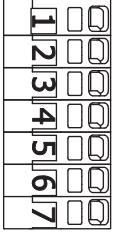
Position magnets

			
<p>Ring magnet OD33 Part no. 201 542-2</p>	<p>Ring magnet OD25.4 Part no. 400 533</p>	<p>U-magnet OD33 Part no. 251 416-2</p>	<p>U-magnet OD63.5 Part no. 201 553</p>
<p>Material: PA ferrite GF20 Weight: Approx. 14 g Surface pressure: Max. 40 N/mm² Fastening torque for M4 screws: 1 Nm Operating temperature: -40...+105 °C (-40...+221 °F)</p>	<p>Material: PA ferrite Weight: Approx. 10 g Surface pressure: Max. 40 N/mm² Operating temperature: -40...+105 °C (-40...+221 °F)</p>	<p>Material: PA ferrite GF20 Weight: Approx. 11 g Surface pressure: Max. 40 N/mm² Fastening torque for M4 screws: 1 Nm Operating temperature: -40...+105 °C (-40...+221 °F)</p>	<p>Material: PA 66-GF30, magnets compound-filled Weight: Approx. 26 g Surface pressure: 20 N/mm² Fastening torque for M4 screws: 1 Nm Operating temperature: -40...+75 °C (-40...+167 °F)</p>

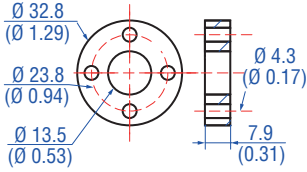
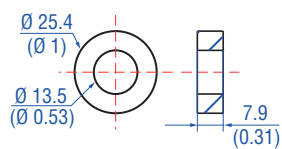
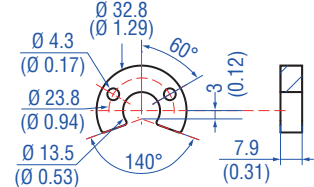
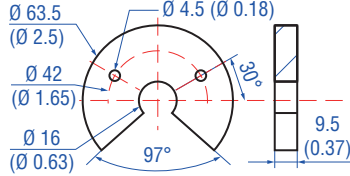
Magnet spacer

Floats³

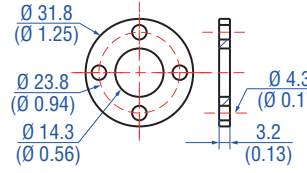
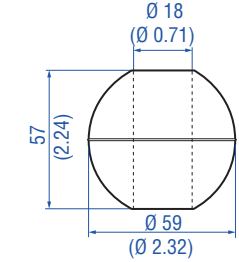
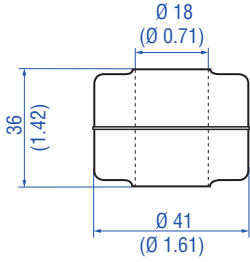
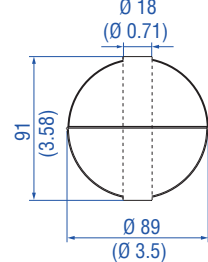
			
<p>Magnet spacer Part no. 400 633</p>	<p>Float Part no. 251 387-2</p>	<p>Float Part no. 200 938-2</p>	<p>Float Part no. 251 469-2</p>
<p>Material: Aluminum Weight: Approx. 5 g Surface pressure: Max. 20 N/mm² Fastening torque for M4 screws: 1 Nm</p>	<p>Material: Stainless steel (AISI 316L) Weight offset: Yes Pressure: 22.4 bar (325 psi) Magnet offset: No Specific gravity: Max. 0.48 Operating temperature: -40...+125 °C (-40...+257 °F)</p>	<p>Material: Stainless steel (AISI 316L) Weight offset: Yes Pressure: 8.6 bar (125 psi) Magnet offset: No Specific gravity: Max. 0.74 Operating temperature: -40...+125 °C (-40...+257 °F)</p>	<p>Material: Stainless steel (AISI 316L) Weight offset: Yes Pressure: 29.3 bar (425 psi) Magnet offset: No Specific gravity: Max. 0.45 Operating temperature: -40...+125 °C (-40...+257 °F)</p>

Controlling design dimensions are in millimeters and measurements in () are in inches

- 3/
- Be sure that the float specific gravity is at least 0.05 less than that of the measured liquid as a safety margin at ambient temperature
 - For interface measurement: A minimum of 0.05 specific gravity differential is required between the upper and lower liquids

- When the magnet is not shown, the magnet is positioned at the center line of float
- An offset weight is installed in the float to bias or tilt the float installed on the sensor tube. So the float remains in contact with the sensor tube at all times and guarantees permanent potential equalization of the float. The offset is required for installations that must conform to hazardous location standards

Floats⁴

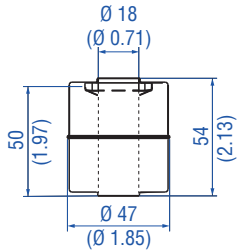
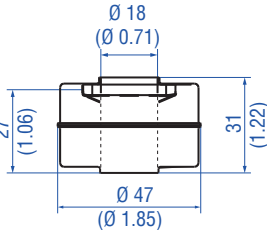
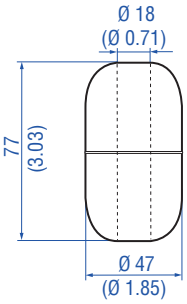
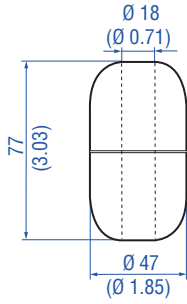
			
<p>Float⁵ Part no. 201 605-2</p> <p>Material: Stainless steel 1.4571 (AISI 316 Ti) Weight offset: Yes Pressure: 4 bar (60 psi) Magnet offset: Yes Specific gravity: Max. 0.6 Operating temperature: -40...+125 °C (-40...+257 °F)</p>	<p>Float⁵ Part no. 201 606-2</p> <p>Material: Stainless steel 1.4571 (AISI 316 Ti) Weight offset: Yes Pressure: 4 bar (60 psi) Magnet offset: Yes Specific gravity: 0.93 ± 0.01 Operating temperature: -40...+125 °C (-40...+257 °F)</p>	<p>Float Part no. 251 982-2</p> <p>Material: Stainless steel (AISI 316L) Weight offset: Yes Pressure: 29.3 bar (425 psi) Magnet offset: No Specific gravity: 0.93 ± 0.01 Operating temperature: -40...+125 °C (-40...+257 °F)</p>	<p>Float Part no. 251 983-2</p> <p>Material: Stainless steel (AISI 316L) Weight offset: Yes Pressure: 29.3 bar (425 psi) Magnet offset: No Specific gravity: 1.06 ± 0.01 Operating temperature: -40...+125 °C (-40...+257 °F)</p>

Float⁴

Collar

Optional installation hardware

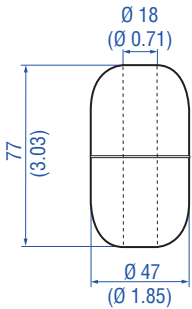
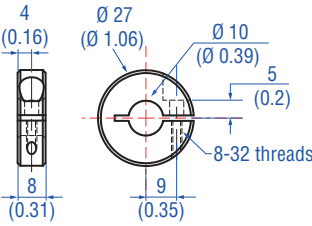
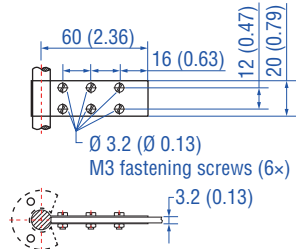
		
<p>Float Part no. 251 981-2</p> <p>Material: Stainless steel (AISI 316L) Weight offset: Yes Pressure: 29.3 bar (425 psi) Magnet offset: No Specific gravity: Max. 0.67 Operating temperature: -40...+125 °C (-40...+257 °F)</p>	<p>Collar Part no. 560 777</p> <p>Provides end of stroke stops for float Material: Stainless steel 1.4301 (AISI 304) Weight: Approx. 30 g Hex key 7/64" required</p>	<p>Fixing clip Part no. 561 481</p> <p>Application: Used to secure sensor rods (Ø 10 mm (Ø 0.39 in.)) when using an U-magnet Material: Brass, non-magnetic</p>

Controlling design dimensions are in millimeters and measurements in () are in inches

- 4/
- Be sure that the float specific gravity is at least 0.05 less than that of the measured liquid as a safety margin at ambient temperature
 - For interface measurement: A minimum of 0.05 specific gravity differential is required between the upper and lower liquids
 - When the magnet is not shown, the magnet is positioned at the center line of float

- An offset weight is installed in the float to bias or tilt the float installed on the sensor tube. So the float remains in contact with the sensor tube at all times and guarantees permanent potential equalization of the float. The offset is required for installations that must conform to hazardous location standards

- 5/ Standard float that can be expedited

Sealings

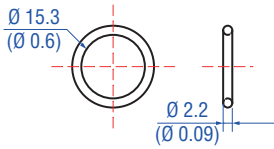

**O-ring for threaded flange M18x1.5-6g
Part no. 401 133**

Material: Fluoroelastomer
75 ± 5 durometer
Operating temperature:
-40...+204 °C (-40...+400 °F)

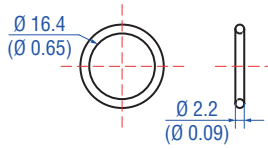

**O-ring for threaded flange 3/4"-16 UNF-3A
Part no. 560 315**

Material: Fluoroelastomer
75 ± 5 durometer
Operating temperature:
-40...+204 °C (-40...+400 °F)

**Manuals, Software & 3D Models available at:
www.mtssensors.com**

Controlling design dimensions are in millimeters and measurements in () are in inches

ORDER CODE

1	2	3	4	5	6	7	8	9	10	11	12	13	14	15	16	17	18	19	20	21	22	23	24	25	
T	H										1			N	N	C									
a		b	c					d			e	f	g	h	i						j				

Optional

a	Sensor model
T H	Rod

b	Design
Enclosure Type 3: TH rod sensor with housing material stainless steel 1.4305 (AISI 303) and rod material stainless steel 1.4306 (AISI 304L)	
M	Threaded flange with flat-face (M18×1.5-6g)
N	Threaded flange with raised-face (M18×1.5-6g)
S	Threaded flange with flat-face (¾"-16 UNF-3A)
T	Threaded flange with raised-face (¾"-16 UNF-3A)

Enclosure Type 3X:	
TH rod sensor with housing material stainless steel 1.4404 (AISI 316L) and rod material stainless steel 1.4404 (AISI 316L)	
F	Threaded flange with flat-face (¾"-16 UNF-3A)
G	Threaded flange with raised-face (¾"-16 UNF-3A)
W	Threaded flange with flat-face (M18×1.5-6g)

c	Stroke length
X X X X M	0025...7620 mm
Standard stroke length (mm)*	
25 ... 500 mm	5 mm
500 ... 750 mm	10 mm
750...1000 mm	25 mm
1000...2500 mm	50 mm
2500...5000 mm	100 mm
5000...7620 mm	250 mm

X X X X U	001.0...300.0 in.
Standard stroke length (in.)*	
1 ... 20 in.	0.2 in.
20 ... 30 in.	0.4 in.
30 ... 40 in.	1.0 in.
40...100 in.	2.0 in.
100...200 in.	4.0 in.
200...300 in.	10.0 in.

d	Connection type
C 0 1	Side connection with thread ½"-14 NPT (All versions)
C 1 0	Top connection with thread ½"-14 NPT (All versions)
M 0 1	Side connection with thread M16×1.5-6H (Version E & N)
M 1 0	Top connection with thread M16×1.5-6H (Version E & N)
N 0 1	Side connection with thread M20×1.5-6H (All versions)
N 1 0	Top connection with thread M20×1.5-6H (All versions)
N F 1	Side connection with thread M20×1.5-6H (Version E & N)

e	Operating voltage
1	+24 VDC (-15 / +20 %)

f	Version (see "Certifications" on page 5 for further information)
D	Ex db and Ex tb (A/F 55)
E	Ex db eb and Ex tb (A/F 55)
G	Ex db and Ex tb (A/F 60) US & CA approval: Explosionproof (XP) (Note: Group A is not available for Canada)
N	Not approved

g	Functional safety type
N	Not approved

h	Additional option type
N	None

i	See next page
---	---------------

* / Non standard stroke lengths are available; must be encoded in 5 mm / 0.1 in. increments

i		Output
C (17) (18) (19) (20) (21) (22) = CANbus		
Protocol ⁶ (box no. 17, 18, 19)		
3	0	4 CANopen
Baud rate (box no. 20)		
1	1000 kBit/s	
2	500 kBit/s	
3	250 kBit/s	
4	125 kBit/s	
Resolution (box no. 21)		
1	5 µm	
2	2 µm	
Performance (box no. 22)		
1	Standard	

Optional:

j		Magnet number for multi-position measurement ⁷
Z	0	2 2 magnets
Z	0	3 3 magnets
Z	0	4 4 magnets

NOTICE

Use magnets of the same type (e.g. 2 ring magnets with part no. 201 542-2) for multi-position measurement.

DELIVERY



Sensor

Accessories have to be ordered separately

**Manuals, Software & 3D Models available at:
www.mtssensors.com**

6/ Please contact MTS Sensors if you are interested in further CAN protocols

7/ Note: Specify magnet numbers for your sensing application and order separately

Document Part Number:
551881 Revision B (EN) 09/2017

LOCATIONS

USA
MTS Systems Corporation
Sensors Division
3001 Sheldon Drive
Cary, N.C. 27513, USA
Tel. +1 919 677-0100
Fax +1 919 677-0200
info.us@mtssensors.com
www.mtssensors.com

JAPAN
MTS Sensors Technology Corp.
737 Aihara-machi,
Machida-shi,
Tokyo 194-0211, Japan
Tel. +81 42 775-3838
Fax +81 42 775-5512
info.jp@mtssensors.com
www.mtssensors.com

FRANCE
MTS Systems SAS
Zone EUROPARC Bâtiment EXA 16
16/18, rue Eugène Dupuis
94046 Creteil, France
Tel. +33 1 58 4390-28
Fax +33 1 58 4390-03
info.fr@mtssensors.com
www.mtssensors.com

GERMANY
MTS Sensor Technologie
GmbH & Co. KG
Auf dem Schüffel 9
58513 Lüdenscheid, Germany
Tel. +49 2351 9587-0
Fax +49 2351 56491
info.de@mtssensors.com
www.mtssensors.com

CHINA
MTS Sensors
Room 504, Huajing Commercial Center,
No. 188, North Qinzhou Road
200233 Shanghai, China
Tel. +86 21 6485 5800
Fax +86 21 6495 6329
info.cn@mtssensors.com
www.mtssensors.com

ITALY
MTS Systems Srl
Sensor Division
Via Camillo Golgi, 5/7
25064 Gussago (BS), Italy
Tel. +39 030 988 3819
Fax +39 030 982 3359
info.it@mtssensors.com
www.mtssensors.com

LEGAL NOTICES

MTS, Temposonics and Level Plus are registered trademarks of MTS Systems Corporation in the United States; MTS SENSORS and the MTS SENSORS logo are trademarks of MTS Systems Corporation within the United States. These trademarks may be protected in other countries. All other trademarks are the property of their respective owners. Copyright © 2017 MTS Systems Corporation. No license of any intellectual property rights is granted. MTS reserves the right to change the information within this document, change product designs, or withdraw products from availability for purchase without notice. Typographic and graphics errors or omissions are unintentional and subject to correction. Visit www.mtssensors.com for the latest product information.

