



Bulletin HY14-2004-B1/US

Series VA20/35 Series VG20/35

Oil Hydraulic Directional Control Valves

Effective: October 1, 2002

Supersedes: H-99 dated 6/99

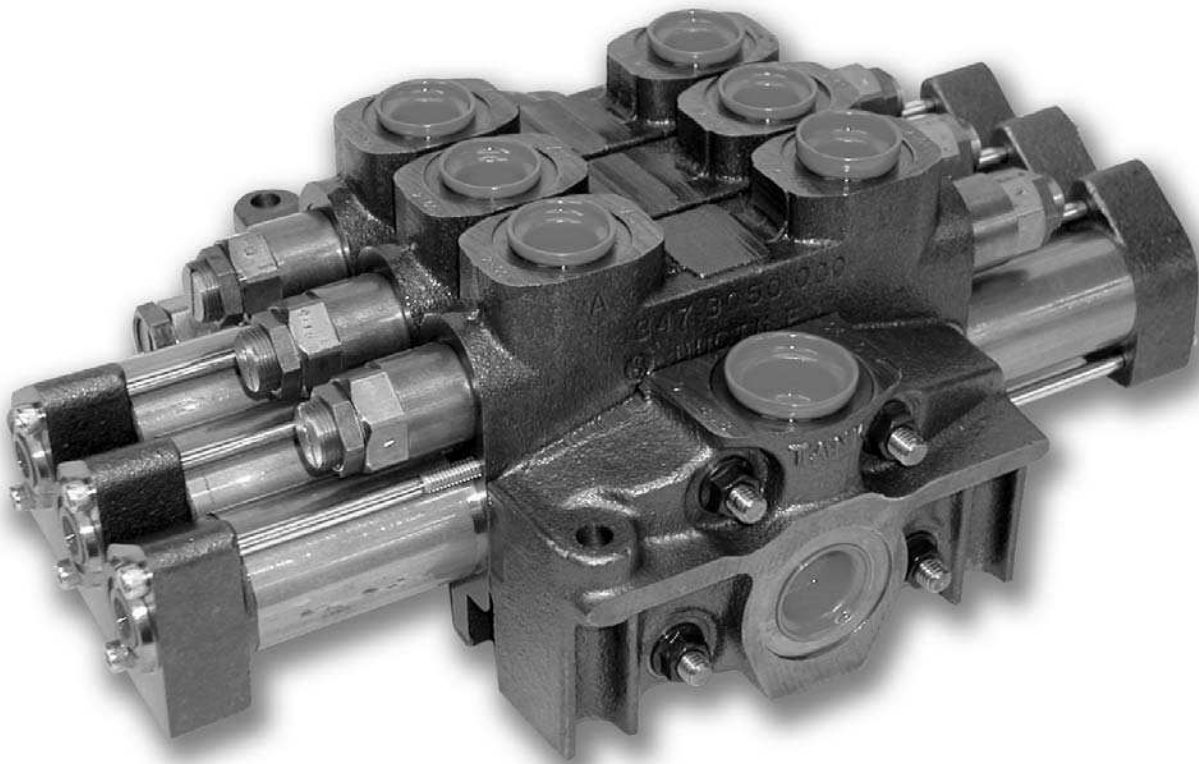

VA20/35 VG20/35 DIRECTIONAL CONTROL VALVES

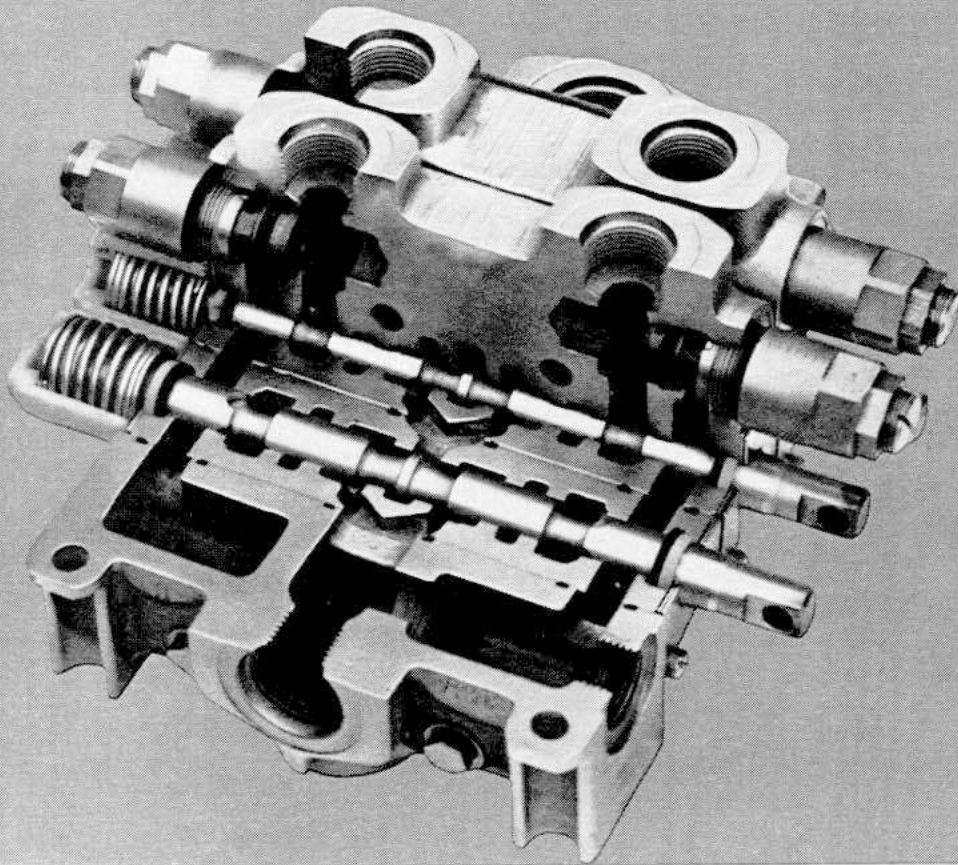

Commercial's VA and VG model valves are contemporary versions of our well-proven A20/A35 units which have provided reliable control of fluid power for over 20 years. The VG models are cast from compacted graphite, a high strength iron alloy that allows us to rate the valves to 3500 psi. VA models are cast from gray iron and are rated at 2500 psi.

Both models are produced under Commercial's Statistical Process Control program. SPC assures you of top quality because all manufacturing processes are constantly monitored to be sure they're within tolerances. SPC is just one method Commercial is using to maintain quality, improve delivery and control costs.

As a worldwide supplier of high quality hydraulic components, we build to the same designs at all of our plants. This assures you that wherever you manufacture or wherever your equipment is used, service parts are readily available.

WARNING

FAILURE OR IMPROPER SELECTION OR IMPROPER USE OF THE PRODUCTS AND/OR SYSTEMS DESCRIBED HEREIN OR RELATED ITEMS CAN CAUSE DEATH, PERSONAL INJURY AND PROPERTY DAMAGE.

This document and other information from Parker Hannifin Corporation, its subsidiaries and authorized distributors provide product and/or system options for further investigation by users having technical expertise. It is important that you analyze all aspects of your application and review the information concerning the product or system in the current product catalog. Due to the variety of operating conditions and applications for these products or systems, the user, through its own analysis and testing, is solely responsible for making the final selection of the products and systems and assuring that all performance, safety and warning requirements of the application are met.

The products described herein, including without limitation, product features, specifications, designs, availability and pricing, are subject to change by Parker Hannifin Corporation and its subsidiaries at any time without notice.

Offer of Sale

The items described in this document are hereby offered for sale by Parker Hannifin Corporation, its subsidiaries or its authorized distributors. This offer and its acceptance are governed by the provisions stated in the "Offer of Sale".

© Copyright 2002, Parker Hannifin Corporation, All Rights Reserved

you get more efficient control of fluid power distribution with Commercial valves because of these important features:

- Built-in, full-flow relief valves
- Parallel and series circuits in one bank
- Manual, hydraulic, electric or pneumatic operation
- Sectional construction for maximum flexibility
- Spool changeover capability for right- or left-hand valve assemblies
- Low spool effort — improved metering

Several features are offered as standard on VA20/35 and VG20/35 valves that contribute to their outstanding performance. Symmetrical timing makes changeover from left-to right-hand operation simply a matter of removing the spool and re-inserting it in the opposite direction. Spool seals are fitted in counter bores for easier maintenance and smoother spool operation. These features, combined with the extensive range of available spool functions and options, make these valves among the most versatile obtainable.

These features, and there are many more, offer advantages to the equipment manufacturer which result in superior control and equipment performance. These valves show a greatly reduced internal pressure drop under all conditions of operation.

low internal pressure drop

All valves present resistance to flow which results in pressure drop. Commercial's valves VA20/35 and VG20/35 are designed with large internal passages with uniform cross sections and smooth wall surfaces which provide flow paths free of abrupt angles. More useful fluid power is available because there is minimal internal pressure drop and less energy wasted in heat generation. Performance data for all operating conditions is plotted in tables and charts on pages 6 and 7. You can use these tables to determine the proper size valve to best meet your specific requirement.

sectional construction

These valves are of sectional, stack type, construction assembled with one or more work sections capped by inlet and outlet sections. Working sections are offered in many functional types. Special mid-inlet sections may be added in the valve bank to introduce the flow from additional pumps. Working sections with series or parallel type circuits can be assembled in thousands of combinations to tailor these valves to your needs.

pressure compensation

VA35 or VG35 parallel circuit sections can have the benefits of outlet pressure compensation. A special pressure compensation out-

let automatically maintains a selected flow through any one of the valve's parallel section. The outlet's metering spool responds to changing pressure providing precise control of machine functions regardless of the level of the operator's skill.

Pressure compensated outlets may be used in mixed bank (series and parallel) assemblies if the series work sections are upstream of the pressure compensated parallel sections.

full-flow relief valve protection

Full-flow system relief valves may be installed in the end inlet section.

Work sections can be provided with full-flow relief valves in either or both work ports. Port relief valves can be pilot operated with anti-cavitation checks or differential area, full-flow relief valves without anti-cavitation checks. (See graphs on pages 10 and 11.) Crossover relief valves are available.

principle components and their functions

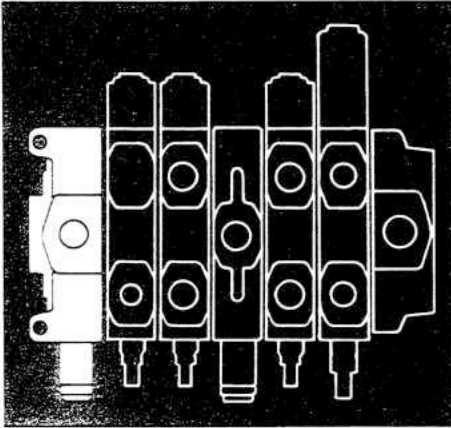

inlet sections

Pump flow is plumbed to stack-type directional control valves through a port placed in an inlet section. Inlet sections are available with or without full-flow system relief valves.

end inlet

End inlets cap the valve bank at the upstream end and receive the primary pump flow. A port is placed in the top or side of the inlet to provide for piping connection.

end inlet, tank return

This style of end inlet section caps the valve bank at the upstream end and receives the primary pump discharge through a top or side port. An additional port, placed in the bottom, provides a route for low-pressure return oil to flow directly to tank. Inlet unloaders are also available. See page 26.

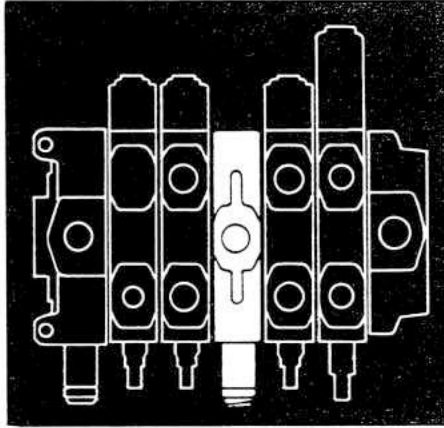

mid-inlet sections

mid-inlet section for split flow

This section allows you to combine two or more independent circuits in one valve bank simplifying plumbing and installation. A split flow, mid-inlet section, positioned between two working sections, provides a method of feeding a secondary pump's flow into a valve bank and acts as an outlet for the primary pump. The secondary pump's flow is directed to that portion of the valve bank downstream from the mid-inlet. The primary pump's flow is not combined with that of the secondary pump within the valve bank. A built-in full-flow relief valve can be provided. Split flow mid-inlets with power beyond capability are also available.

for combined flow

A combined flow, mid-inlet section can be positioned between two working sections to introduce flow from a secondary pump into the valve bank. The secondary pump's flow is added to that of the primary pump to feed all downstream working sections. The primary pump flow is interrupted when an upstream section is activated but flow from secondary pump remains available. Total discharge (gpm) from primary and secondary pumps may not exceed the flow capacity of the valve bank.

for combination split or combined flow (manual selection)

This combination mid-inlet section has an integral, manually operated, two-position spool. In the split-flow position, the valve directs secondary pump flow to the downstream portion of the valve bank and directs the primary pump's discharge to tank. In the combined flow position, the two pump flows are combined at the end inlet and made available to all working sections. Combined discharge (gpm) from primary and secondary pumps may not exceed maximum flow capacity of the valve bank.

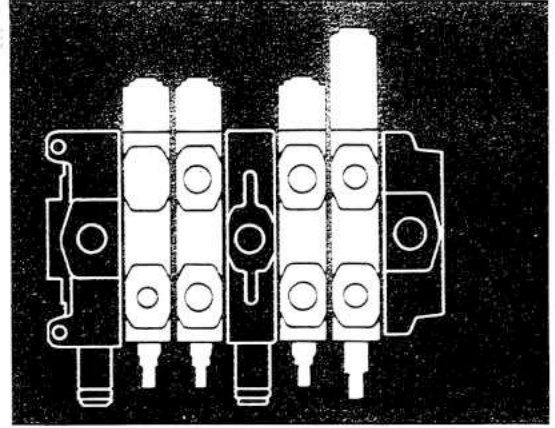

working sections

Lo-Boy sections are protected in working position by a full flow relief valve in the valve's inlet (standard valve). Hi-Boy sections can be ordered with built-in, work port relief valves in either or both ports. Hi-Boy work sections have necessarily higher profiles to accommodate the port relief valves.

Parallel and series circuits can be combined in the same valve bank and are available in both Hi-Boy and Lo-Boy sections. While both circuit types permit actuation of several machine functions, it is important to remember the primary difference between the two types.

parallel circuits

Parallel circuits are the most commonly used because more than one function can be operated simultaneously and at random. However, if two or more spools are fully operated at the same time the one with the lightest load will operate first. An operator can easily overcome this by metering back the valve controlling the lightest load.

series circuits

If more than one spool is operated, the one closest to the inlet will operate first. Return flow is directed to the open center for use by the next work section, etc. The sum of the pressures is additive and can not exceed the system pressure.

3-way • 3-position type
(work port blocked when spool in neutral)
(parallel circuitry only)

In neutral, flow passes through the valve's center flow to another valve bank. This flow is the spool directs all flow out of the one port. Shifting in the opposite direction permits oil to return to tank through the same port. Use with single-acting cylinders or single-direction motors plumbed to tank.

4-way • 3-position type
(work ports blocked when spool in neutral)

Used in parallel or series circuits, both ports are opened (one for outgoing oil, one for returning oil) when the spool is shifted in either direction. Return oil goes downstream through the open center in series circuits or the tank return passage in parallel circuits. Work ports are blocked in neutral. This section controls double-acting cylinders.

4-way • 3-position type
(work ports open when spool in neutral)

This section works the same as the 4-way 3-position cylinder type except that both work ports are connected internally to tank and blocked to pump flow when the spool is in neutral. This section is used in motor circuits.

4-way • 4-position type
(work ports blocked when spool in neutral — open in float position) (parallel circuitry only)

This type valve section stops all return flow in neutral thus stopping the motor or cylinder. The fourth spool position connects the work ports to tank which lets the operator free-wheel the motor or float the cylinder.

4-way • 4-position type
(work ports blocked when spool in neutral — regenerative flow in fourth position) (parallel circuitry only)

When the valve spool is moved into a work position, all of the flow is directed to one work port. At the same time, the other work port is opened to return flow to tank. In the regenerative position, return flow from the rod end of the cylinder is combined with flow from the pump and the additive flow is directed to cylinder's base end. Both work ports are blocked in neutral.

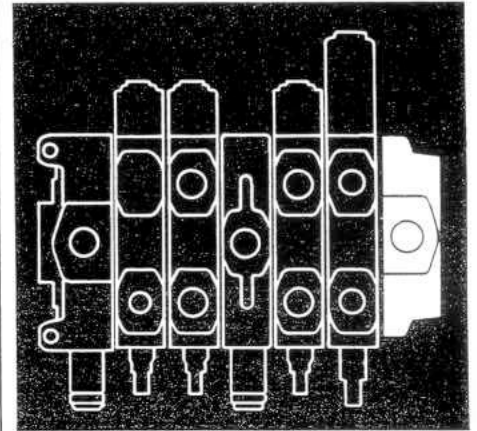

outlet sections

Pump flow leaves the valve through ports placed in an outlet section which caps the valve bank at the downstream end. Outlet sections are available as tank return, pressure beyond or combination types.

tank return type

Ports in the side and top of this outlet permit flow to be piped to tank. Connections can be made to either port. The port not being used must be plugged.

pressure beyond type

Two outlet ports are located in the side or top. The port nearest the centerline directs open center flow to another valve bank. This flow is available to the second bank only when all upstream work sections are in neutral. The second outlet port must be plumbed to tank.

tank return or pressure beyond (convertible)

This outlet can be converted from a tank return type to pressure beyond by inserting a special cartridge plug in the side port. This feature is useful if you anticipate the possible addition of an accessory valve after the machine is built.

tank return priority outlet type (divided flow)

This outlet provides ports to both the tank and pressure beyond circuits. A built-in flow divider spool directs a selected portion of the flow to the pressure beyond circuit at all times and the remaining flow to tank.

VA20/VG20

performance data

parallel circuit

inlet to outlet

(SAE-16 inlet and outlet)

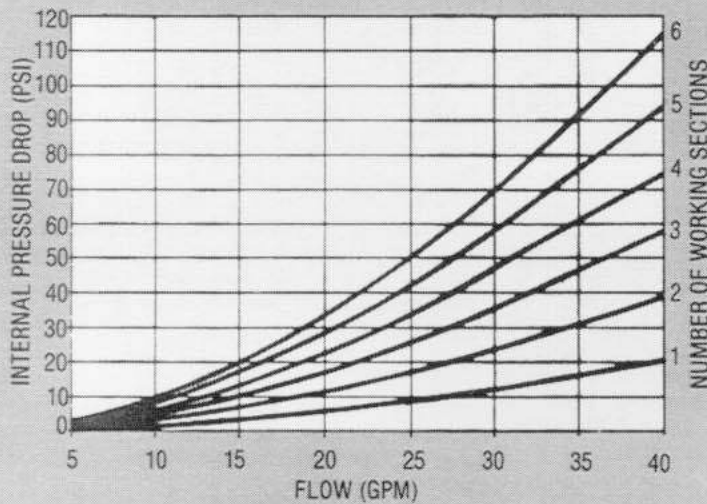

parallel circuit

inlet to work port, work port to outlet

(SAE-16 inlet to SAE-12)

(work ports to SAE-16 outlet)

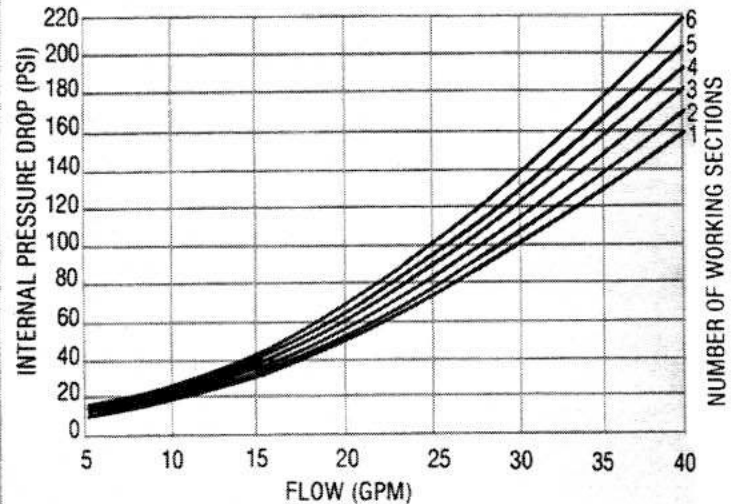

series circuit

inlet to outlet

(SAE 16 inlet and outlet)

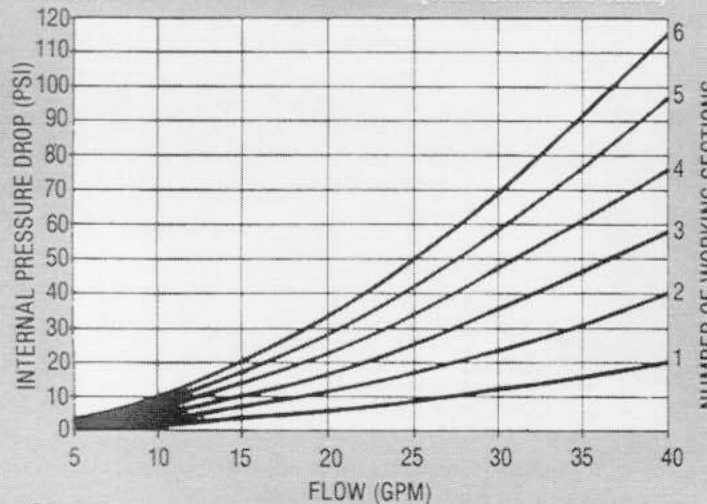

series circuit

inlet to work port, work port to outlet

(SAE-16 inlet to SAE-12)

(work ports to SAE-16 outlet)

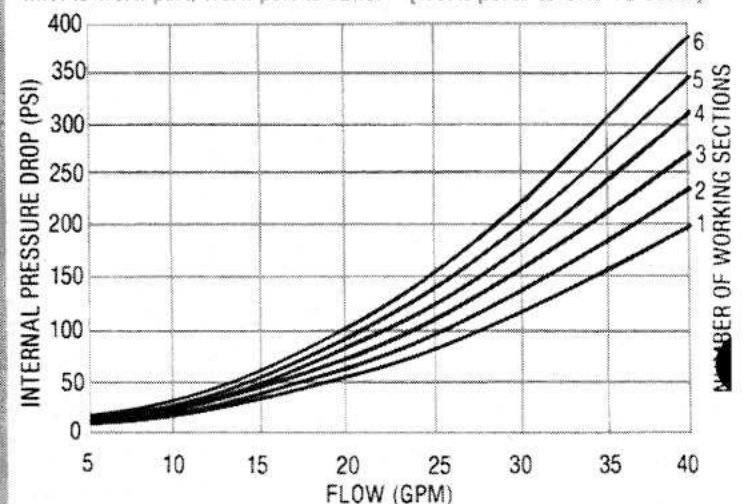

VA35/VG35

performance data

parallel circuit

inlet to outlet

(SAE-20 inlet to SAE-16 work
part to SAE-20 outlet)

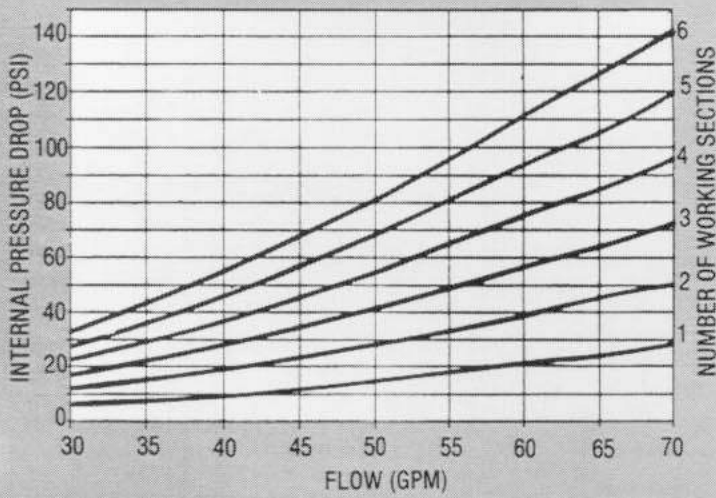

parallel circuit

inlet to work part, work part to outlet

(SAE-20 inlet and outlet)

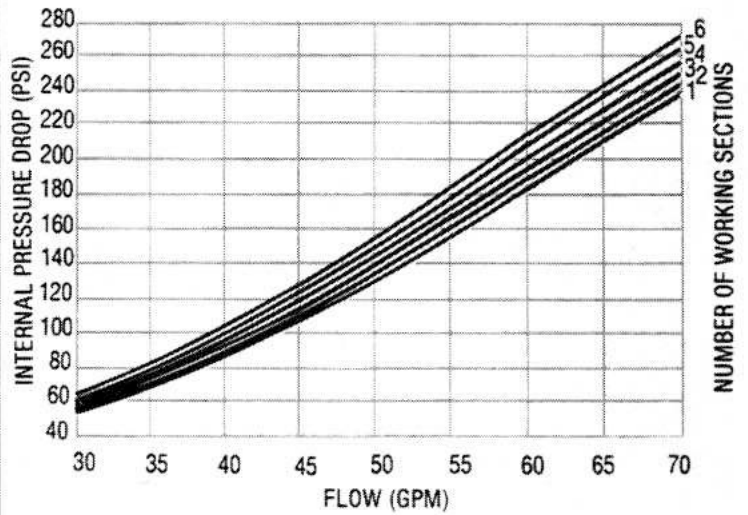

NOTE: VA models are constructed of grey iron and are rated for 2500 psi in 40 gpm (VA20) and 70 gpm (VA35) sizes. VG models are constructed of compacted graphite and are rated for 3500 psi service in corresponding gallonage sizes.

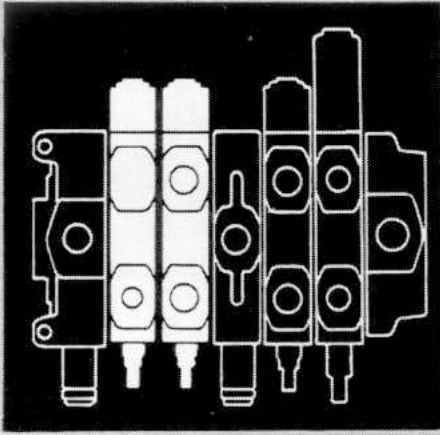

LO-BOY Working Sections

parallel

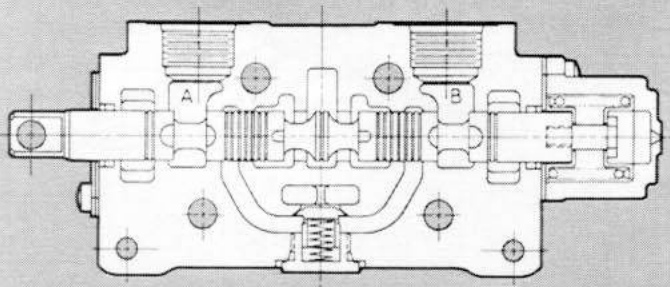

series

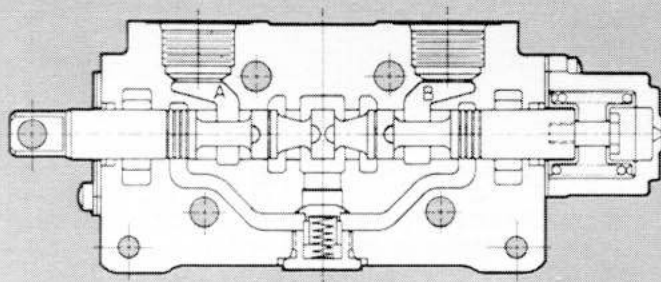

Commercial's VA and VG models are open-center, stack type valves designed primarily for heavy-duty mobile equipment applications. They work equally well with fixed or variable displacement pumps.

VA and VG valves may be used as closed center units with pressure compensated pumps. Valves are made closed center by using a power beyond outlet and plugging the high pressure port.

VA and VG valves are available in two types of work sections called Hi-Boys and Lo-Boys. Parallel or series circuits are available.

Lo-Boys can be used in most circuits requiring only the main relief valve protection provided by a cartridge relief at the inlet. Their lower profile is well suited to applications requiring compact banks such as subsurface mining equipment. Lo-Boy sections, because they require less material and machining, cost less than their Hi-Boy counterparts.

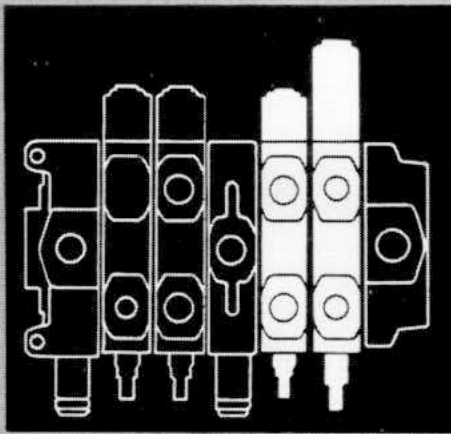

HI-BOY Working Sections

Hi-Boys, as their name implies, are made taller from top to bottom to provide room for optional port accessories. Full-flow, pilot operated relief valves with anti-cavitation checks, differential area relief valves, crossover relief valves for motors and plain anti-cavitation checks can be built into the Hi-Boy sections.

Hi-Boy and Lo-Boy sections can be assembled together in one valve bank so that sections requiring port relief valves, crossover relief or anti-cavitation checks can be inserted as needed for greater economy.

Both Hi-Boy and Lo-Boy sections are rated for 2500 psi in gray iron or 3500 psi in compacted graphite. The full range of spool actuators including electric, hydraulic, electrohydraulic, pneumatic and others shown on pages 12 and 13 can be used with either configuration.

parallel

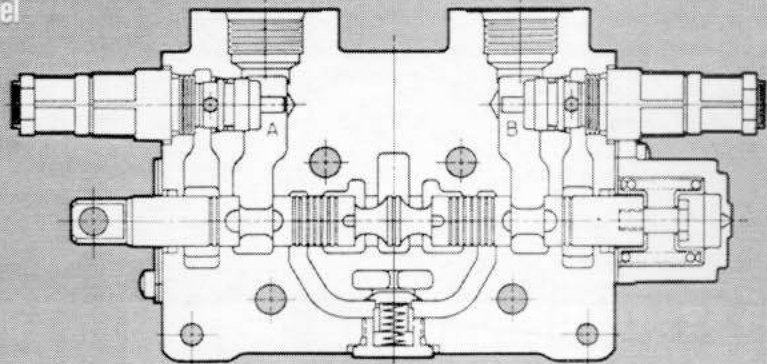

series

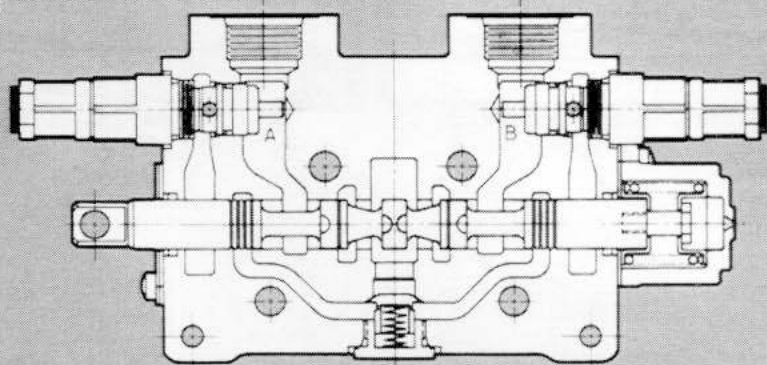

Parker Hannifin Corporation
Hydraulic Valve Division
Hicksville, Ohio, USA

auxiliary valves

relief valves

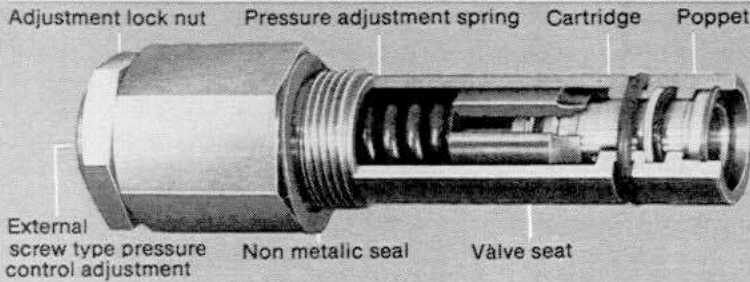

main system relief valve

Three types of relief valves are offered to protect VA- and VG-Line valves against pressure overloads. These include a pilot-operated, full-flow port relief with built-in anti-cavitation feature; a full-flow differential area port relief without anti-cavitation feature and a full-flow inlet or mid-inlet system relief.

Inlet and mid-inlet relief valve protects all downstream work sections. Port reliefs, available in Hi-Boy sections only, offer complete overload protection to each port. These

are particularly useful in sections subject to overloading even in neutral position. An excavator traveling over uneven terrain with its boom extended, for example, could create hydraulic shock loads in the cylinders. Such loads should be relieved at the port to prevent damage to components.

Consistent accuracy in providing adequate pressure relief protection is the hallmark of Commercial's relief valves as shown in the performance graphs below.

VA20/VG20 main relief valve performance

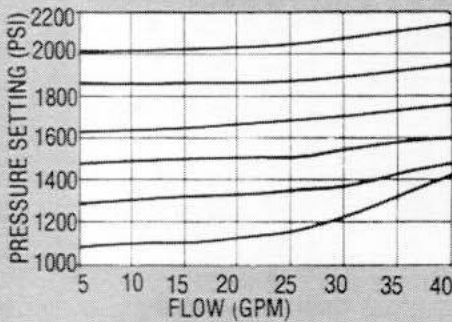

VA35/VG35 main relief valve performance

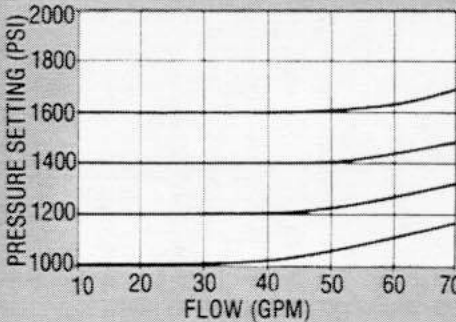

NOTE: Unless otherwise specified main relief valves will be screw adjusted.

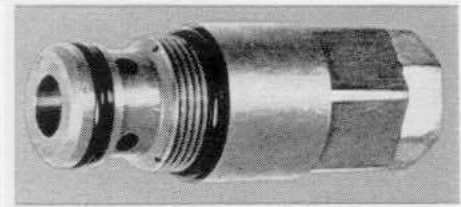

standard port relief (slug adjusted)

Full-flow, differential area type relief valves are the standard port relief valves offered for use in VG and VA valves. Available in Hi-Boy sections only.

The port relief protects the cylinder or motor to which it is plumbed against overload damage. Generally set at a higher pressure than the main system relief valve, the overload port relief functions only when the valve is in neutral. Because of their full-flow capability, they can provide relief valve protection to individual ports which must be operated at pressures below the relief valve setting for the bank assembly.

standard port relief valve performance

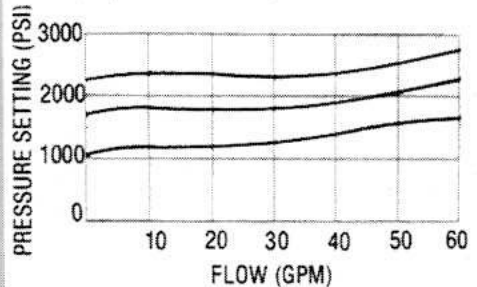

NOTE:

Also available

- Vented anti-cavitation checks
- Lockout relief valves
- Dual-pressure relief valves

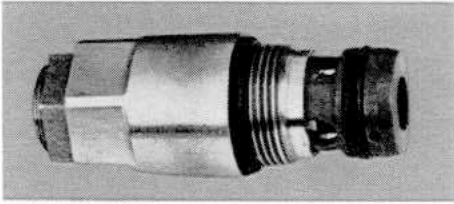

optional port relief (screw adjusted)

Full-flow, pilot-operated relief valves with built-in, anti-cavitation checks are available as port relief valves in VG and VA Hi-Boy models.

optional port relief valve performance

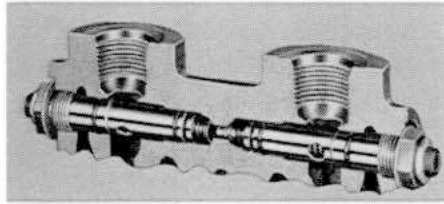
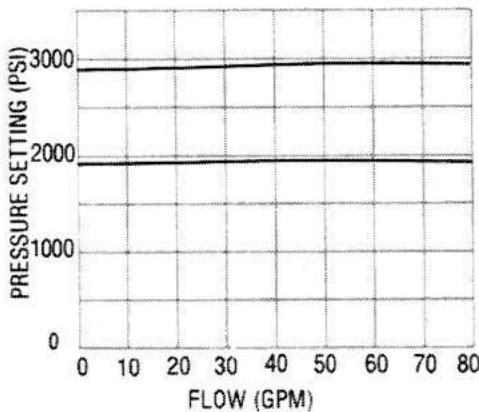

crossover relief valves (screw adjusted)

These allow high pressure to be bled from one work port to the other when the spool is in neutral to prevent an over-running motor from acting as a pump and pressurizing the system beyond its designed load. They also provide anti-cavitation protection to the opposite port.

crossover relief valve performance

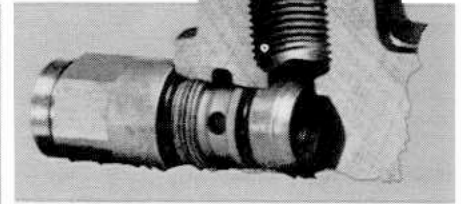
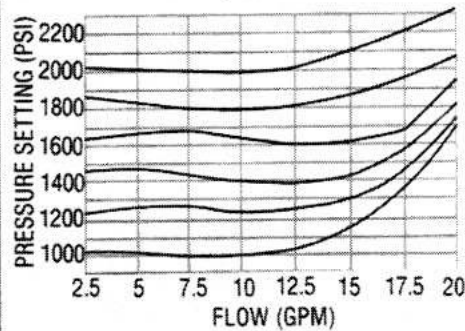

anti-cavitation vacuum check

These checks are available as a built-in feature of the full-flow port relief valves or as separate units to eliminate cavitation beyond the work port. Anti-cavitation checks are available only in Hi-Boy sections.

Cavitation occurs any time an actuator under load demands more flow than the pump can supply. The anti-cavitation check bleeds oil from the tank return passage, feeding it to the low-pressure side of the actuator to fill the vacuum thus preventing cavitation. Anti-cavitation checks function when the valve is in a work position or in neutral.

anti-cavitation check performance

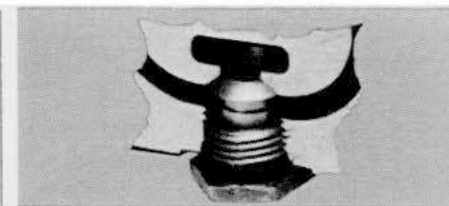
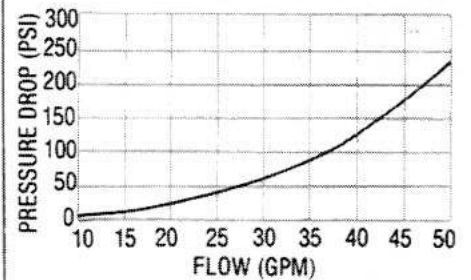

transition check

Transition checks block pressurized return flow while the work section spool is shifted. This momentary holding action permits smoother cylinder or motor operation. The check blocks pressurized return flow until forced open by pressure in the parallel passage. Transition checks are standard on all cylinder work sections. Transition checks are not load-hold checks.

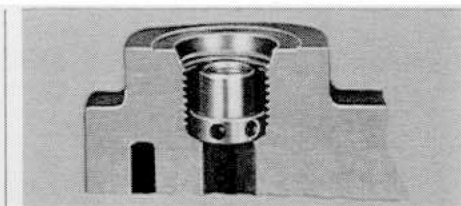

flow restrictor port check

Installed in either work port, these checks reduce return flow to a specified rate determined by the need of the application. They may be used, for example, to slow retractor of a cylinder under load.

Choice of operators

dimensional data, inches $\frac{VA20/VG20}{VA35/VG35}$

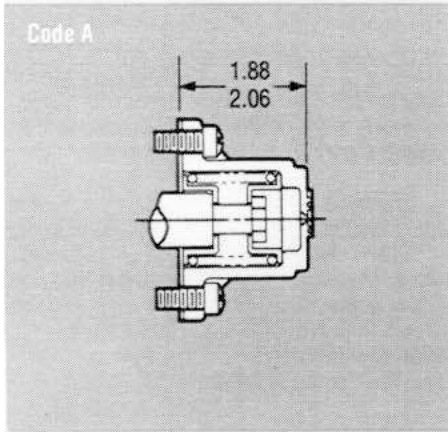

spring return

A spring in the end cap of this standard spool operator returns the spool to neutral from either work position when the control handle is released.

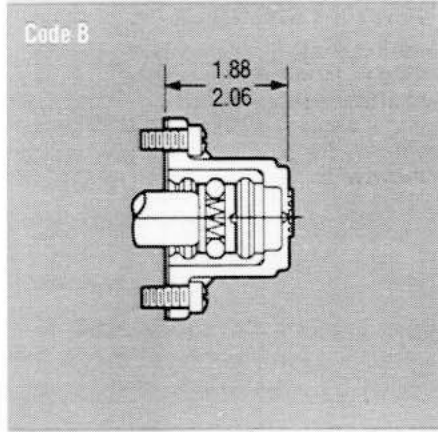

3-position detent

This option allows the spool to be detented in any of three positions. Spool movement from one position to another or to neutral is done manually.

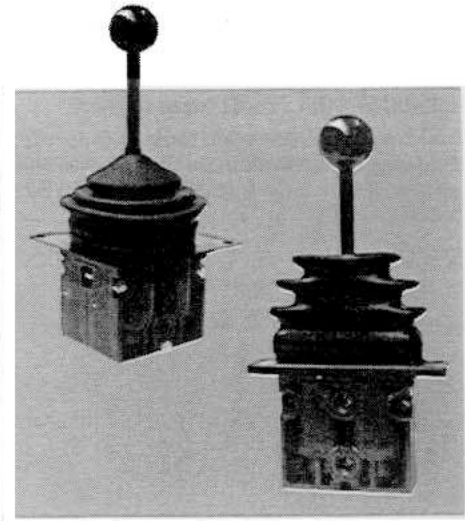

pneumatic remote controllers

Stackable and joystick models are available. They require 11.7 cfm at 100 psi. Max operating pressure is 142 psi. These lightweight units can be ordered with a variety of handle configurations to make operation of stackable sections easier. Ask for catalog H111.

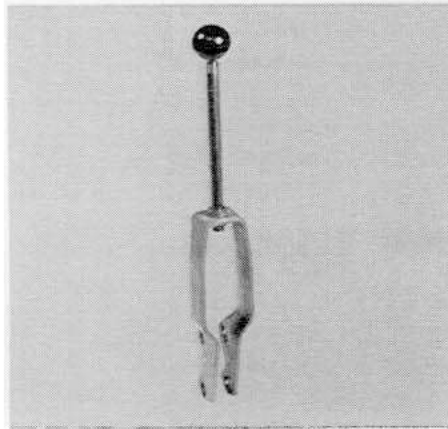

VA/VG valve handles

Stamped steel handles fit either Hi-Boy or Low-Boy models with or without port reliefs. Handle height may be adjusted by varying the length of threaded rod portion. Standard heights are 6", 8" and 10".

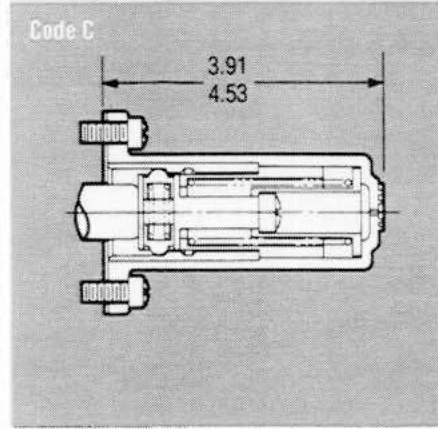

detent with spring return

When used with a float section, the spool may be detented in the float position to allow a cylinder to float or a motor to freewheel until manually shifted.

Spring action returns the spool to neutral from work positions.

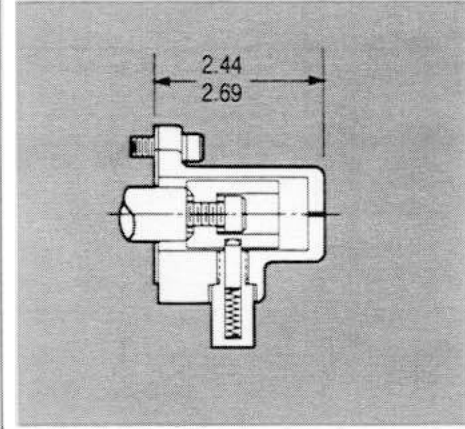

rotary back cap

Rotating the control handle, instead of pushing or pulling it, actuates this spool. The handle will hold in any position between 0° and 90° either side of center to provide a continuous flow of metered oil. These units are available with stainless steel parts for marine winch applications. Buyer must supply handle.

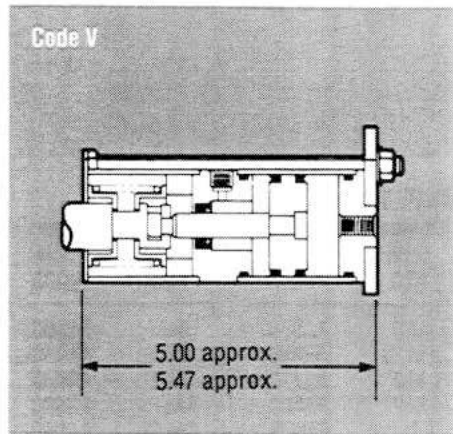

single ended pneumatic

This option uses a 100 psi pneumatic pilot, plumbed to double-acting piston on one end of the spool. This piston shifts the spool in either direction thus freeing the opposite spool end to accept a handle operator which may be used as an override.

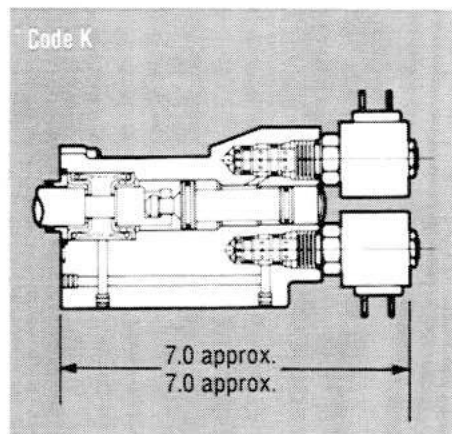

solenoid operated

End cap mounted solenoids with equal area pistons utilize a 300 psi pilot signal to shift the spool. Pilot supply connections are internal to the valve. The equal area solenoid pistons prevent ghosting. This operator can be adjusted to control the spool's rate of travel. Contact Commercial for solenoid applications.

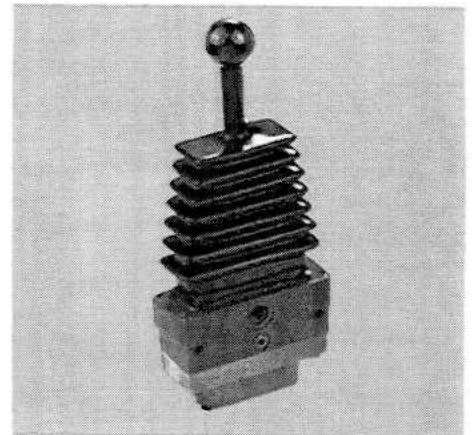

oil hydraulic remote controller

Joystick type remote controllers provide precise control of two directional control valve sections. These units require 3-5 gpm pilot flow at up to 500 psi. Joystick models can be equipped with electrical switches and manual or electro-magnetic detents. Ask for catalog H-68R.

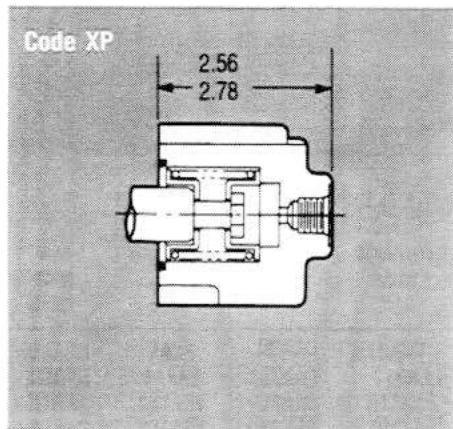

pilot operated

This option uses a 100 psi pilot signal to shift the spool in either direction. As caps are required on both ends, manual actuation is not possible.

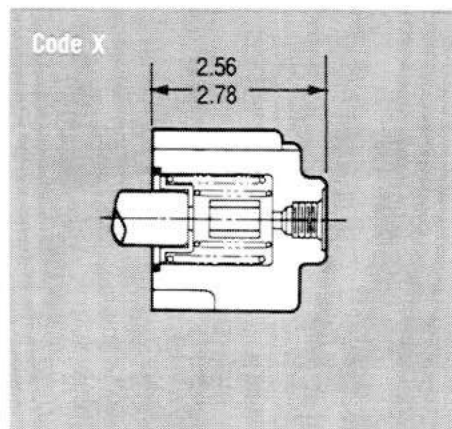

remote operated back cap

These sections may be matched with Commercial's oil hydraulic remote controllers for precisely metered remote valve control when manual operation is impractical. Pressure is bled from the main system or provided by an auxiliary circuit.

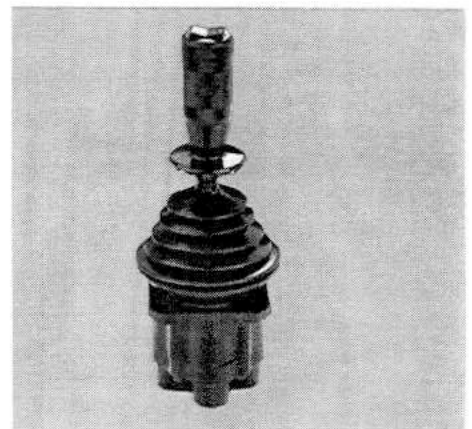

oil hydraulic remote controller

Single axis remote controllers operate one directional control valve section. They require 3-5 gpm pilot flow at up to 500 psi. Single axis models can be stacked in several configurations and are available with a foot pedal. Ask for catalog H-68.

how to code VA20/35 - VG20/35 valves

- Determine the system pressure and required flow through the valve and select the appropriate valve model.
- Determine the number and order of sections required.
- Specify the requirements for each of the sections — and select the appropriate codes for those requirements.
- Assemble the code, specifying the model and then each section starting with the inlet and continue to the outlet.

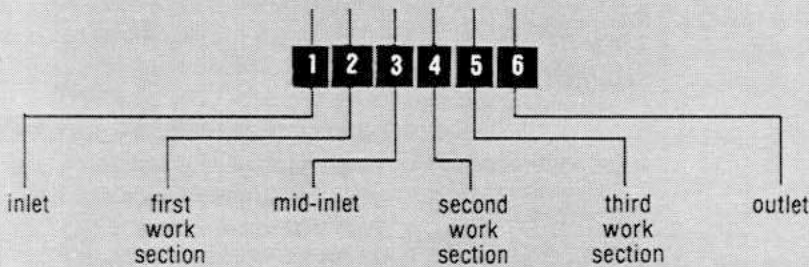
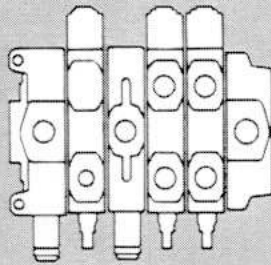

section

requirements

code

Model (page 17)	System pressure = 2000 psi — valve flow = 35 gpm	VA20
1 Inlet (pages 16 & 17)	Standard inlet with relief valve set at 2000 psi and — 16- <small>SAE</small> straight thread top ports	AA080 (2000)
2 First Work Section (pages 20 & 21)	Lo-Boy — double-acting cylinder, parallel circuit — spring return — 12- <small>SAE</small> straight thread ports	DA7
3 Mid-section Inlet (pages 18 & 19)	Combined flow type without a relief valve — 12- <small>SAE</small> straight thread port	CCA70
4 Second Work Section (pages 20 & 21)	Lo-Boy — double-acting motor, parallel circuit — spring return — 12- <small>SAE</small> straight thread port	MA7
5 Third Work Section (pages 20 & 21)	Lo-Boy — double-acting cylinder, parallel circuit — solenoid operated — 12- <small>SAE</small> straight thread port	DK7
6 Outlet Section (pages 24 & 25)	Return to tank type — 16- <small>SAE</small> straight thread top port	Z080

example of assembled valve ordering code

VA20-AA080 (2000) - DA7 - CCA70 - MA7 - DK7 - Z080

code cross reference

NOTE: These tables are provided as a cross reference for customers who have been using A-Line valves which are superseded by VA and VG model valves. Coding for VA and VG models differs from that for A-Line models.

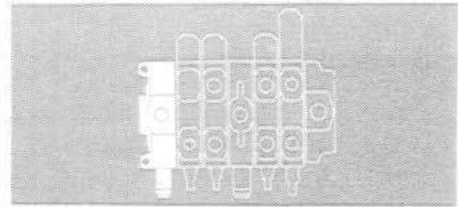

inlet sections

previous code	new code	previous code	new code
A20	VA20	A35	VA35
AA5	AA330	AA1	AA300
AA128	AA440	AA4	AA440
AA130	AA770	AA91	AA880
AA127	AA880	AA17	AA080
AA19	AA070	AA14	AA900
CA2	CA300	AA92	AA980
CA127	CA880	CA5	CA303
CA130	CA770	CA92	CA980

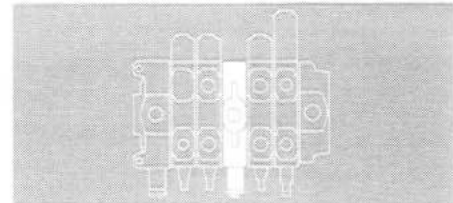

mid-inlet sections

previous code	new code	previous code	new code
A20	VA20	A35	VA35
EAA3	CAA30	EAA3	CAA40
EAA11	CAA70	EAA14	CAA80
EAA110	SAA70	EAA103	SAA40
EAA123	SAA33	EAA112	SAA80
ECA11	CCA70	EAA125	SAA44
ECA103	SCA30	EAA141	SAA88
		ECA3	CCA40
		ECA14	CCA80

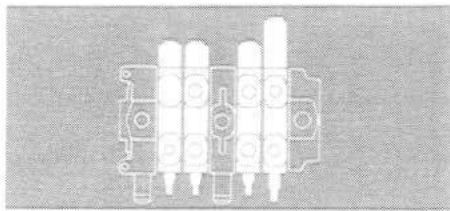

working sections

previous code A20	new code VA20	previous code A20	new code VA20
DA52	DA2	HB168	HB533
DA53	DA3	HB170	HB733
DA55	DA5	HB178	HB330
DA56	DA6	HB190	HB303
DA57	DA7	HB194	HB703
DB52	DB2	HB653	HB344
DB53	DB3	HB657	HB744
DB55	DB5	HC53	HC300
DB57	DB7	HS3	HS300
DC53	DC3	2HS3	HR300
DS3	DS3	HS7	HS700
4DS3	DR3	HS116	HS333
DS7	DS7	HS120	HS733
2DS7	DR7	3HS120	HR733
FB53	FB3	HS128	HS330
FB57	FB7	1HS220	HR722
FC53	FC3	HS603	HS344
FC57	FC7	3HS603	HR344
GC57	—	HS607	HS744
GC170	—	JA57	JA700
GC257	—	JA190	JA303
GC657	—	JB52	JB200
HA52	HA200	JB53	JB300
HA53	HA300	JB190	JB303
HA56	HA600	JB194	JB703
HA57	HA700	JC190	JC303
HA120	HA733	JC194	JC703
HA165	HA233	JS3	JS300
HA166	HA333	JS140	JS303
HA168	HA533	JS144	JS703
HA169	HA633	KA180	KA530
HA170	HA733	KB180	KB530
2HA177	HA230	KC55	KC500
HA178	HA330	KC180	KC530
HA181	HA630	LA52	LA200
HA182	HA730	LA53	LA300
HA190	HA303	LA56	LA600
1HA193	HA603	LA57	LA700
HA194	HA703	LA168	LA533
HA266	HA322	LA190	LA303
HA270	HA722	1LA269	LA622
HA282	HA720	1LA270	LA722
HA653	HA344	LA653	LA344
HA656	HA644	LA656	LA644
HA657	HA744	LA657	LA744
HB53	HB300	LB53	LB300
HB56	HB600	LB55	LB500
HB57	HB700	LB56	LB600
HB166	HB333	LB57	LB700

previous code A20	new code VA20
LB168	LB533
LS3	LS300
LS7	LS700
1LS607	LR744
MA52	MA2
MA53	MA3
MA57	MA7
MB52	MB2
MB53	MB3
MB57	MB7
MC53	MC3
ME57	ME7
MS3	MS3
MS7	MS7
NA53	NA3
NB53	NB3
NB57	NB7
SA52	SA2
SA53	SA3
SA55	SA5

previous code A35	new code VA35
DA51	DA2
DA52	DA3
DA53	DA4
DA56	DA6
DA57	DA7
DA59	DA8
DA63	DA5
DB52	DB3
DB53	DB4
DB57	DB7
DB59	DB8
DB63	DB5
DS3	DS4
1DS3	DR4
DS9	DS8
2DS9	DR8
FC53	—
FC59	—
GC166	GC411
GC172	GC811
GC266	GC422
GC472	GC811
HA53	HA400
HA57	HA700
1HA57	HA700
HA59	HA800
HA159	HA832
HA166	HA433
HA170	HA733
HA172	HA833
HA178	HA430
HA182	HA730
1HA182	HA730

previous code A20	new code VA20
SA57	SA7
SA59	SA9
SB53	SB3
SB57	SB7
SC53	SC3
TA52	TA2
TA53	TA3
TA57	TA7
TA59	TA9
WDA53	WDA3
WDA55	WDA5
WDA57	WDA7
WDB53	WDB3
WDB57	WDB7
WMA53	WMA3
WMA57	WMA7
WMB53	WMB3
WMB57	WMB7
WME57	WME7

previous code A35	new code VA35
HA190	HA403
2HA190	HA409
HA194	HA703
1HA194	HA703
HA196	HA803
HA266	HA422
HA272	HA822
HA284	HA820
HA472	HA811
HA653	HA444
HA659	HA844
HB166	HB433
*HB172	HB833
HB178	HB430
HB184	HB830
HB190	HB403
HB484	HB810
HB653	HB444
HB659	HB844
HS9	HS800
1HS9	HR800
HS116	HS433
HS122	HS833
1HS122	HR833
HS422	HR811
HS603	HS444
1HS609	HR844
LA53	LA400
LA57	LA700
LA59	LA800
1LA166	LA499
LA170	LA733
LA172	LA833

previous code A35	new code VA35
1LA178	LA490
LA196	LA803
LA659	LA844
LB53	LB400
LB172	LB833
1LS9	LR800
MA53	MA4
MA57	MA7
MA59	MA8
1MA59	MA8
MB53	MB4
MB59	MB8
ME59	ME8
MS3	MS4
3MS3	MR4

previous code A35	new code VA35
MS9	MS8
WDA52	WDA3
WDA53	WDA4
WDA59	WDA8
WDB53	WDB4
WDS9	WDS8
1WDS9	WDR8
1WHS7	WHR700
1WHS120	WHR711
WMA53	WMA4
WMA59	WMA8
WMB53	WMB4
WMB59	WMB8
WMS9	WMS8
1WMS9	WMR8

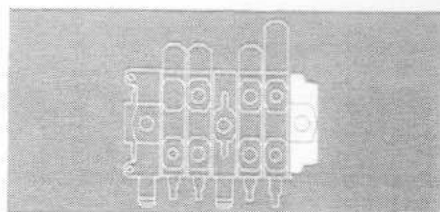

outlet sections

previous code A20	new code VA20	previous code A35	new code VA35
AY606	AY40040	AY663	AY90090
CY658	CY80080	CY663	CY90090
DY606	DY40040	DY663	DY90090
Z2	Z400	Z3	Z040
Z3	Z330	Z16	Z550
Z11	Z070	Z20	Z880
Z14	Z880	Z10	Z900
Z16	Z440	Z17	Z990
Z18	Z870	Z15	Z980
1ZT4	ZT040	ZT17	ZT990
Y4	Y30030	Y63	Y90090
Y6	Y40040	Y12	Y35035
Y12	Y24024	Y89	Y39039
Y82	Y28028	Y180	Y90039
Y164	Y80028		
Y182	Y44044		

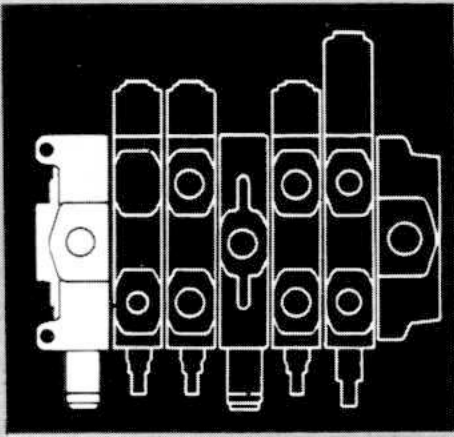

inlet sections

standard type

bottom dump to tank type

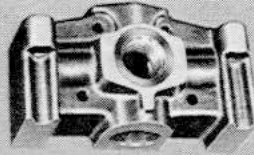
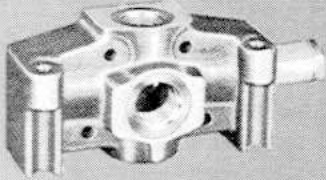

dimensional data, inches VA20/VG20
VA35/VG35

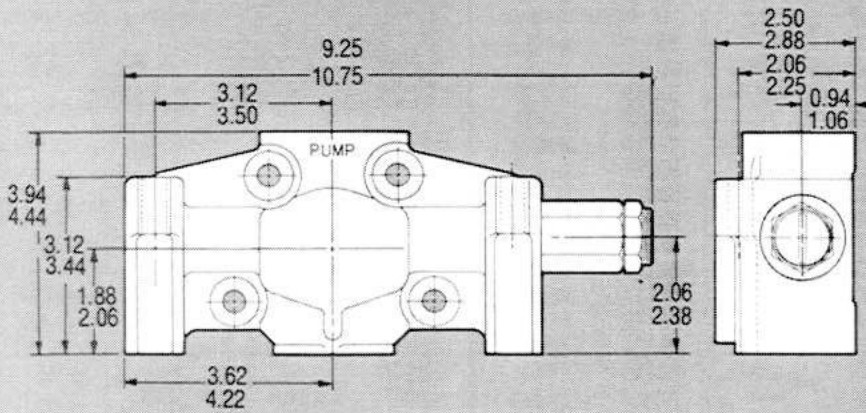

typical schematic

Code AA

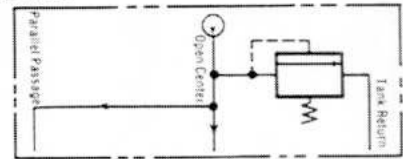



function

code	description
** AA	— standard inlet with screw adjusted relief valve
CA	— standard inlet without screw adjusted relief valve, cavity plugged



high pressure port, side



high pressure port, top



low pressure port bottom

description	porting			
	VA20 code	VA35 code	VG20 code	VG35 code
no port	0	0	0	0
3/4" split flange	1	1	1	1
1/2" NPT **	2	2		
3/4" NPT **	3	3		
1" NPT **	4	4		
1" split flange		5		5
SAE-10	6		6	
SAE-12	7	7	7	7
SAE-16	8	8	8	8
SAE-20		9		9

**NOTE: NPT ports are not available for VG models.

example of coding for inlet sections

VA20 -A A 7 7 0 (2000)

- AA — standard inlet with screw adjusted relief valve
- 7 — SAE-12 high pressure port, side
- 7 — SAE-12 high pressure port, top
- 0 — no port, bottom

VA35 -C A 0 3 3

- CA — standard inlet without screw adjusted relief valve, cavity plugged
- 0 — no port, side
- 3 — 3/4" NPT high pressure port, top
- 3 — 3/4" NPT low pressure port, bottom

SAE J846 tube coding system

Nominal Tube O.D., in	Dash Size Symbol
1/2	-8
5/8	-10
3/4	-12
7/8	-14
1	-16
1 1/4	-20

**NOTE: When ordering inlets please identify pressure and flow for main relief valve setting, see example above.

Codes in blue panels are standard and are readily available from stock.

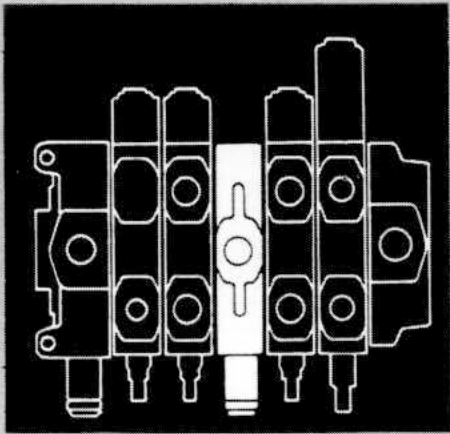

mid-inlet sections

split flow type –
combined flow type

split or combined flow type
(manual operation)

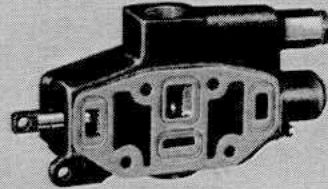
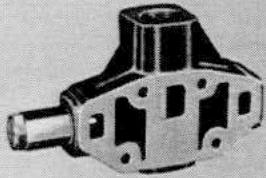

dimensional data, inches $\frac{VA20/VG20}{VA35/VG35}$ (Codes SAA, SCA, CAA and CCA)

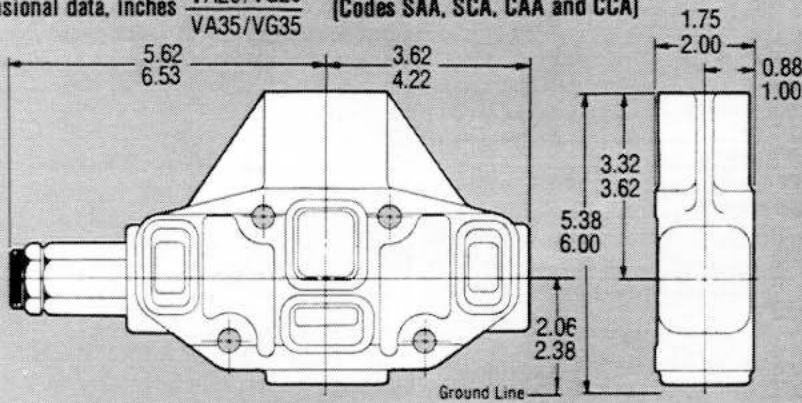

dimensional data, inches $\frac{VA20/VG20}{VA35/VG35}$ (Codes XCA and XAA)

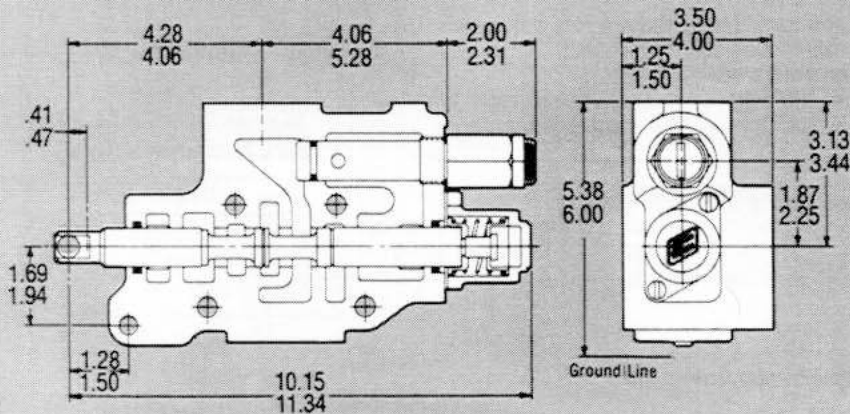

typical schematic

Code SAA

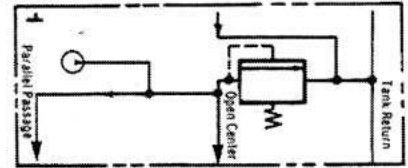

Code CAA

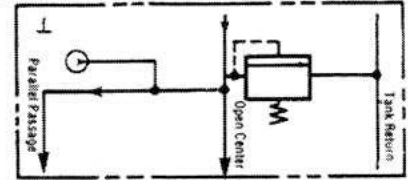

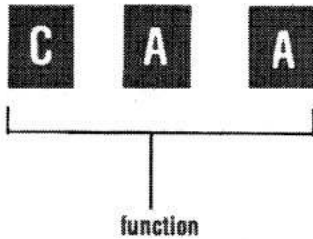

- | code | description |
|------------|------------------------------------|
| SAA | split flow with relief valve |
| SCA | split flow without relief valve |
| CAA | combined flow with relief valve |
| CCA | combined flow without relief valve |
| XAA | selector with relief valve |
| XCA | selector without relief valve |



porting

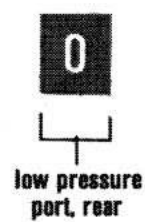

description	VA20 code	VA35 code	VG20 code	VG35 code
no port	0	0	0	0
3/4" split flange		1		1
1/2" NPT **	2		2	
3/4" NPT **	3	3	3	3
1" NPT **		4		4
SAE-8	5		5	
SAE-10	6	6	6	6
SAE-12	7	7	7	7
SAE-16		8		8

**NOTE: NPT ports are not available for VG models.

example of coding for mid-inlet sections

VA20 - C A A 7 0 (2000)

- CAA — combined flow with relief valve
- 7 — SAE-12 high pressure port, top
- 0 — no port, rear

VA20 - S A A 8 8 (1500)

- SAA — split flow with relief valve
- 8 — SAE-16 high pressure port, top
- 8 — SAE-16 low pressure port, rear

SAE J846 tube coding system

Nominal Tube O.D., in	Dash Size Symbol
1/2	-8
5/8	-10
3/4	-12
7/8	-14
1	-16
1 1/4	-20

*NOTE: When ordering mid-inlets please identify relief valve pressure and flow requirements, see example above.

Codes in blue panels are standard and are readily available from stock.



Parker Hannifin Corporation
Hydraulic Valve Division
Hicksville, Ohio, USA

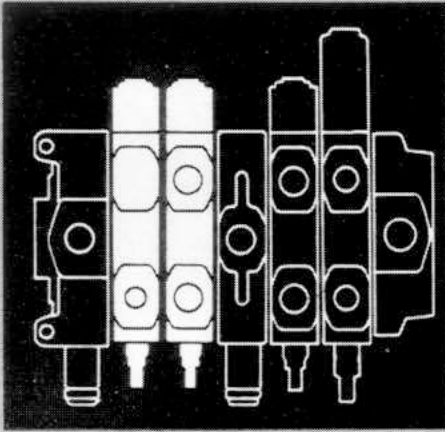

LO-BOY working sections

manual operation

pilot operated

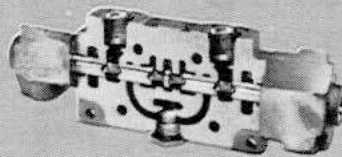
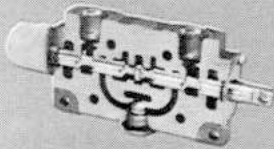

dimensional data, inches
VA20/VG20
VA35/VG35

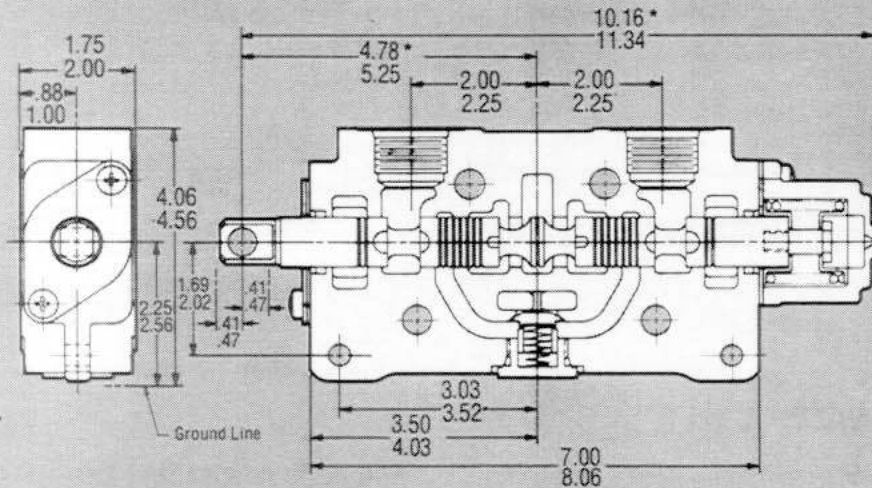

* These dimensions are shown for a manually operated valve with spring return. See operators pages 12 and 13 for other combinations.

typical schematic

Code SA

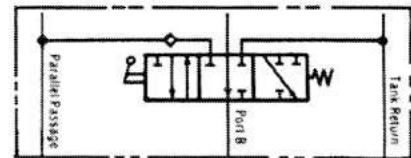

Code DR

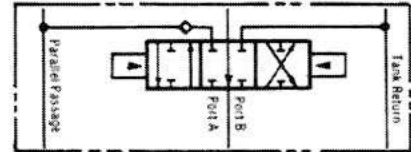

Code MS

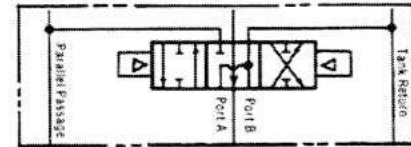

Code WDK

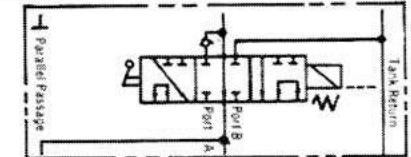

Code FC

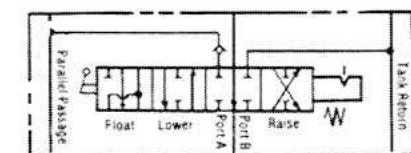

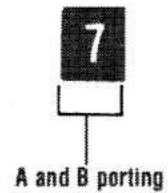
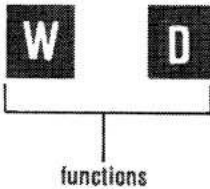

code	description
D	double-acting, parallel, cylinder
M	double-acting, parallel, motor
WD	double-acting, series, cylinder
WM	double-acting, series, motor
S	single-acting, (B port), parallel, cylinder
N	single-acting, (B port), parallel, motor
T	single-acting, (A port), parallel, cylinder
F	double-acting, with 4th position

code	description	code	description
A	spring return	E	split flange
B	3-position detent	F	1/2 NPT**
C	spring return with 4th position detent	N/A	3/4 NPT**
XP	pilot operated	XP	1 NPT**
X	hydraulic remote	X	SAE-8
K	solenoid	L	SAE-10
Q	electro-magnetic detent	M	SAE-12
P	remote w/solenoid lockout	P	SAE-16
V	single ended pneumatic	U	SAE-20

description	VA20 code	VA35 code	VG20 code	VG35 code
3/4 split flange		1		1
1/2 NPT**	2			
3/4 NPT**	3	3		
1 NPT**		4		
SAE-8	5	5	5	5
SAE-10	6	6	6	6
SAE-12	7	7	7	7
SAE-16	8*	8	8*	8
SAE-20		9*		9*

*dimensional data shown does not apply to this section

• see pages 12 and 13 for operator dimensional data

*these ports restricted to 60% of PSI —
VA 1500 psi
VG 2100 psi
**NPT ports not available on VG models

example of coding LO-BOY working sections:

VA20 - WDE-7

WD — double-acting, series, cylinder type
E — spring return operator at A port end
7 — SAE-12

VA35 - M B 8

M — double-acting, parallel, motor
B — 3-position detent operator
8 — SAE-16 A and B ports

SAE J846 tube coding system

Nominal Tube O.D., in	Dash Size Symbol
1/2	-8
5/8	-10
3/4	-12
7/8	-14
1	-16
1 1/4	-20

Codes in blue panels are standard and are readily available from stock.

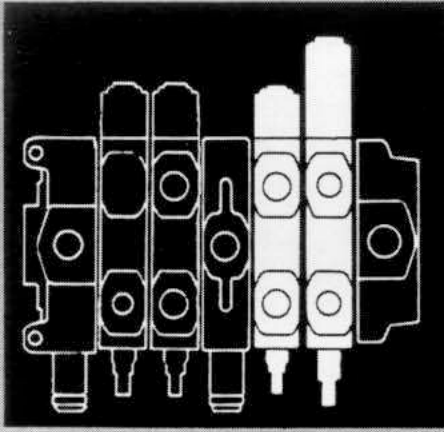

HI-BOY Working Sections

manual operation

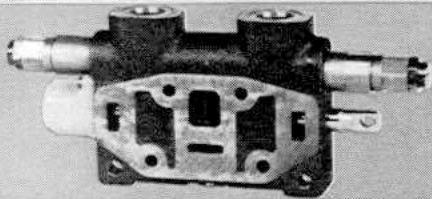

pilot operated

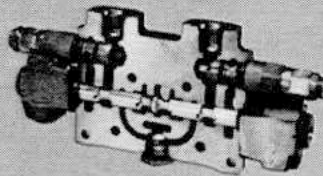

dimensional data, inches $\frac{VA20/VG20}{VA35/VG35}$

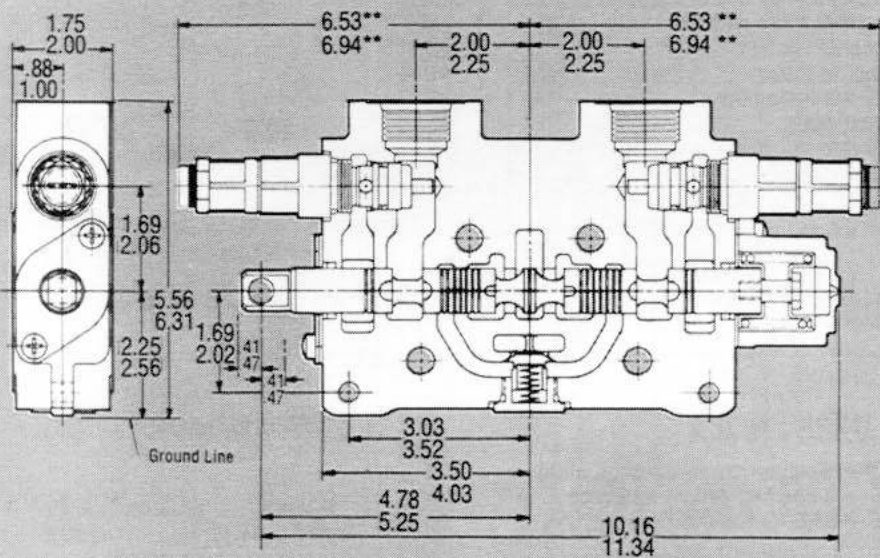

**maximum dimensions shown with adjustable screw backed out as far as normally expected.

typical schematic

Code JA

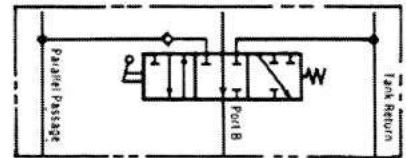

Code HR

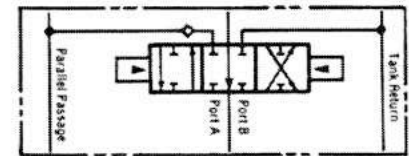

Code LS

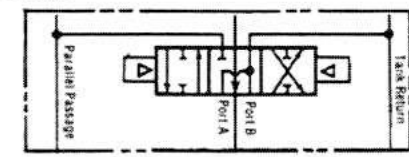

Code WHK

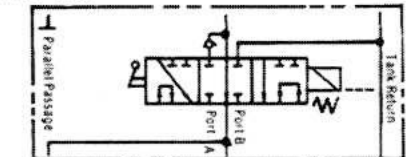

Code GC

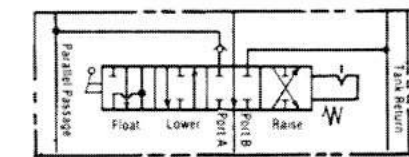

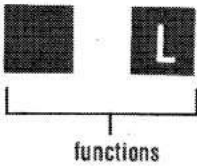

code	description
L	double-acting, parallel, cylinder
L	double-acting, parallel, motor
WH	double-acting, series, cylinder
WL	double-acting, series, motor
J	single-acting, (B port), parallel, cylinder
G	double-acting, with 4th position parallel, float*
K	single-acting, (A port), parallel, cylinder
R	regeneration hi-boy, VA35 only. *dimensional data shown does not apply to this section



left hand assembly operator is at B port end		right hand assembly operator is at A port end	
code	description	code	description
A	spring return	E	spring return
B	3-position detent	F	3-position detent
C	spring return with 4th position detent	N/A	
XP	pilot operated	XP	pilot operated
X	hydraulic remote	X	hydraulic remote
K	solenoid	L	solenoid
Q	electro-magnetic detent	M	electro-magnetic detent
P	remote w/solenoid lockout	P	remote w/solenoid lockout
V	single ended pneumatic	U	single ended pneumatic

• see pages 12 and 13 for operator dimensional data



VA20/ VG20		VA35/ VG35	
code	description	code	description
	1/4 split flange	1	1/4 split flange
2	1/2 NPT**		
3	3/4 NPT**	3	3/4 NPT**
	1 NPT**	4	1 NPT**
5	SAE-8	5	SAE-8
6	SAE-10	6	SAE-10
7	SAE-12	7	SAE-12
8*	SAE-16	8	SAE-16
	SAE-20	9*	SAE-20

*these ports restricted to 60% of PSI—VA 1500 psi VG 2100 psi
**NPT ports not available on VG models



port A		port B	
code	description	code	description
0	not machined	0	not machined
1	relief valve and anti-cavitation	1	relief valve and anti-cavitation
2	anti-cavitation	2	anti-cavitation
3	relief valve	3	relief valve
4	crossover relief	4	crossover relief
9	plugged	9	plugged

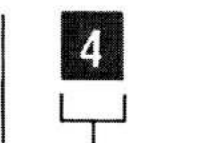

port A		port B	
code	description	code	description
0	not machined	0	not machined
1	relief valve and anti-cavitation	1	relief valve and anti-cavitation
2	anti-cavitation	2	anti-cavitation
3	relief valve	3	relief valve
4	crossover relief	4	crossover relief
9	plugged	9	plugged

NOTE: When specifying circuit relief valves please specify relief valve settings, see examples below.

example of coding HI-BOY working sections:

VA20 -L X-7 4 4 (1000/1000)

- L — double-acting, parallel, motor
- X — hydraulic remote operator
- 7 — SAE-12 A and B porting
- 4 — crossover relief in port A (1000)
- 4 — crossover relief in port B (1000)

VA20 H A-6 1 1 (1500/2000)

- H — double-acting, parallel, cylinder
- A — spring return operation
- 6 — SAE-10 A and B porting
- 1 — relief valve and anti-cavitation in port A (1500)
- 1 — relief valve and anti-cavitation in port B (2000)

SAE J846 tube coding system

Nominal Tube O.D., in	Dash Size Symbol
1/2	-8
5/8	-10
3/4	-12
7/8	-14
1	-16
1 1/4	-20

Codes in blue panels are standard and are readily available from stock.

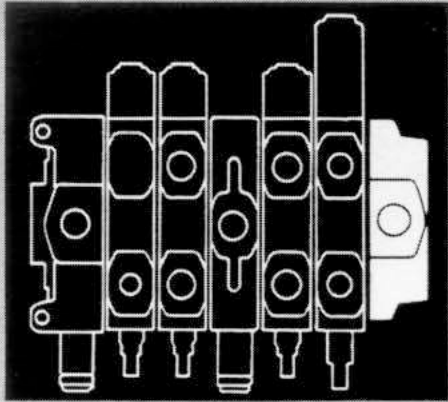

outlet sections

tank return type pressure beyond
or tank return type (convertible)

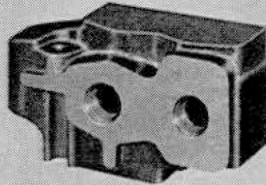
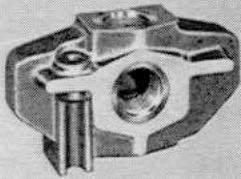

dimensional data, inches $\frac{VA20/VG20}{VA35/VG35}$ (Code Z)

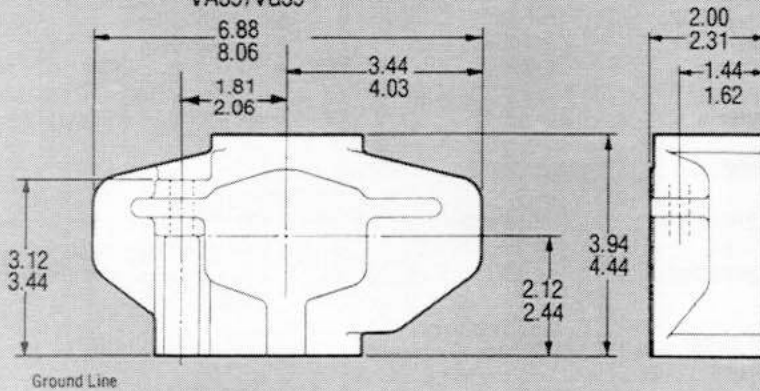

dimensional data, inches $\frac{VA20/VG20}{VA35/VG35}$ (Codes DY, CY and AY)

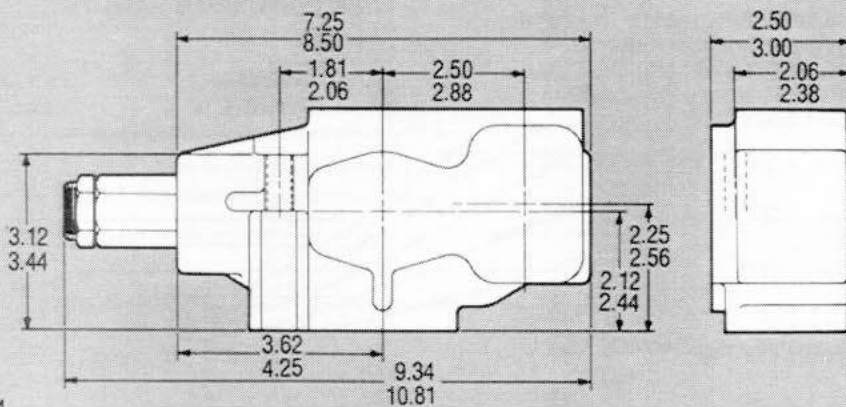

typical schematic

Code Z

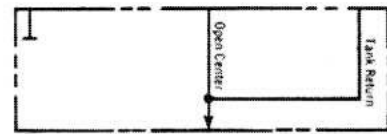

Code Y

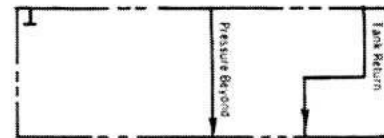

Code AY

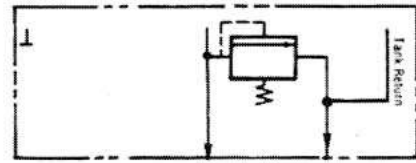

NOTE: Dimensions do not necessarily apply to all types of thru stud outlets.



function

code	description
Z	standard low pressure outlet
ZT*	thru stud low pressure outlet
Y	standard pressure beyond outlet
YT*	thru stud power beyond outlet
DY	convertible type; short plug for low pressure at all ports
CY	convertible type; long plug for pressure beyond; no relief valve
*** AY	convertible type with pressure beyond and with relief valve *thru stud outlets must be used with VG assemblies.

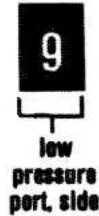

low pressure port, side



low pressure port, top



low pressure port, bottom

Applicable to power beyond valves only.

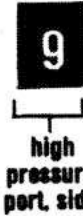

high pressure port, side



high pressure port, top

porting

description	VA20 code	VA35 code	VG20 code	VG35 code
no port	0	0	0	0
3/4" split flange	1**		1**	
1/2" NPT	2			
3/4" NPT	3	3		
1" NPT	4	4		
1 1/4" NPT		.5**		
SAE-10	6		6	
SAE-12	7	7	7	7
SAE-16	8	8	8	8
SAE-20		9		9

**cannot be used with bottom dump porting.

NOTE: NPT ports are not available for VG models.

example of coding for outlet sections

A Y 9 0 0 9 0 (1500)

- AY — convertible type with pressure beyond and with relief valve(1500)
- 9 — SAE-20 low pressure port, side
- 0 — no port, top
- 0 — no port, bottom
- 9 — SAE-20 high pressure port, side
- 0 — no port, top

Z 8 8 0

- Z — standard low pressure outlet
- 8 — SAE-16 low pressure port, side
- 8 — SAE-16 low pressure port, top
- 0 — no port, bottom

SAE J846 tube coding system

Nominal Tube O.D., in	Dash Size Symbol
1/2	-8
5/8	-10
3/4	-12
7/8	-14
1	-16
1 1/4	-20

***NOTE: When ordering power beyond outlets with relief valves please specify relief valve flow and pressure, see example above.

Codes in blue panels are standard and are readily available from stock.



Parker Hannifin Corporation 25
Hydraulic Valve Division
Hicksville, Ohio, USA

accessories and other valve products

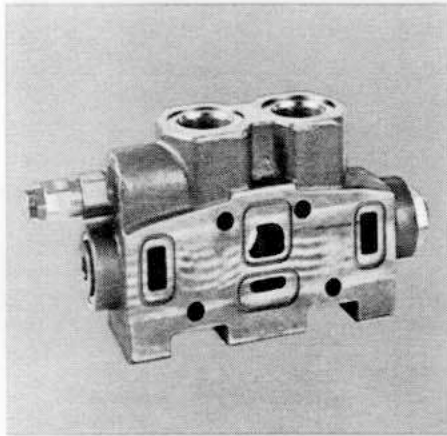

VA/VG inlet unloader

An optional inlet unloader improves high flow performance of VA/VG20 and 35 valves by diverting pump flow directly to tank until a work spool is actuated. This makes it unnecessary to disengage the pump during roading and allows a smaller more economical control valve to be used.

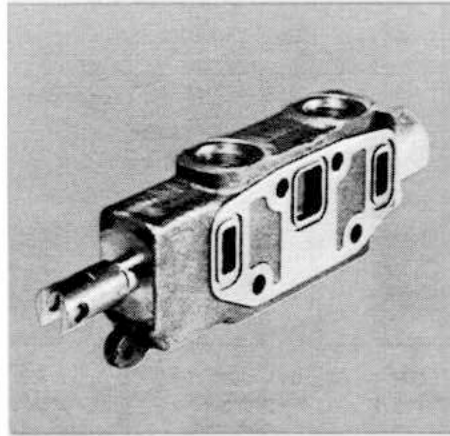

automatic kickout valve

Automatic kickout sections are detented in a work position by the operator. When pressure at the work port reaches a pre-set level, pilot flow from the port releases the detent mechanism and the spool is spring-returned to neutral. Highboy versions are also available.

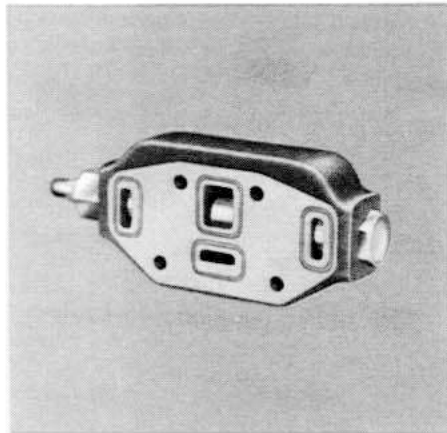

flow control section

This section maintains constant flow to all downstream sections by metering flow through a fixed orifice. Six orifice sizes for flows from 3 gpm to 16 gpm are offered.

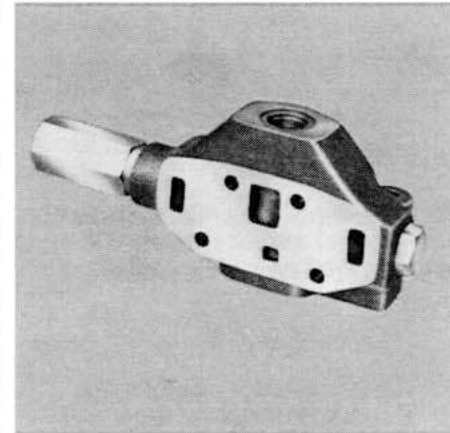

pressure compensating outlet (VA/VG models)

This outlet automatically meters flow through work ports of any upstream parallel section. It may be used in a mixed circuit bank if all series sections are upstream of the parallel sections.

Offer of Sale

The items described in this document and other documents or descriptions provided by Parker Hannifin Corporation, its subsidiaries and its authorized distributors are hereby offered for sale at prices to be established by Parker Hannifin Corporation, its subsidiaries and its authorized distributors. This offer and its acceptance by any customer ("Buyer") shall be governed by all of the following Terms and Conditions. Buyer's order for any such items, when communicated to Parker Hannifin Corporation, its subsidiary or an authorized distributor ("Seller") verbally or in writing, shall constitute acceptance of this offer.

1. Terms and Conditions of Sale: All descriptions, quotations, proposals, offers, acknowledgments, acceptances and sales of Seller's products are subject to and shall be governed exclusively by the terms and conditions stated herein. Buyer's acceptance of any offer to sell is limited to these terms and conditions. Any terms or conditions in addition to, or inconsistent with those stated herein, proposed by Buyer in any acceptance of an offer by Seller, are hereby objected to. No such additional, different or inconsistent terms and conditions shall become part of the contract between Buyer and Seller unless expressly accepted in writing by Seller. Seller's acceptance of any offer to purchase by Buyer is expressly conditional upon Buyer's assent to all the terms and conditions stated herein, including any terms in addition to, or inconsistent with those contained in Buyer's offer. Acceptance of Seller's products shall in all events constitute such assent.

2. Payment: Payment shall be made by Buyer net 30 days from the date of delivery of the items purchased hereunder. Amounts not timely paid shall bear interest at the maximum rate permitted by law for each month or portion thereof that the Buyer is late in making payment. Any claims by Buyer for omissions or shortages in a shipment shall be waived unless Seller receives notice thereof within 30 days after Buyer's receipt of the shipment.

3. Delivery: Unless otherwise provided on the face hereof, delivery shall be made F.O.B. Seller's plant. Regardless of the method of delivery, however, risk of loss shall pass to Buyer upon Seller's delivery to a carrier. Any delivery dates shown are approximate only and Seller shall have no liability for any delays in delivery.

4. Warranty: Seller warrants that the items sold hereunder shall be free from defects in material or workmanship for a period of 18 months from date of shipment from Parker Hannifin Corporation. **THIS WARRANTY COMPRISES THE SOLE AND ENTIRE WARRANTY PERTAINING TO ITEMS PROVIDED HEREUNDER. SELLER MAKES NO OTHER WARRANTY, GUARANTEE, OR REPRESENTATION OF ANY KIND WHATSOEVER. ALL OTHER WARRANTIES, INCLUDING BUT NOT LIMITED TO, MERCHANTABILITY AND FITNESS FOR PURPOSE, WHETHER EXPRESS, IMPLIED, OR ARISING BY OPERATION OF LAW, TRADE USAGE, OR COURSE OF DEALING ARE HEREBY DISCLAIMED. NOTWITHSTANDING THE FOREGOING, THERE ARE NO WARRANTIES WHATSOEVER ON ITEMS BUILT OR ACQUIRED WHOLLY OR PARTIALLY, TO BUYER'S DESIGNS OR SPECIFICATIONS.**

5. Limitation Of Remedy: SELLER'S LIABILITY ARISING FROM OR IN ANY WAY CONNECTED WITH THE ITEMS SOLD OR THIS CONTRACT SHALL BE LIMITED EXCLUSIVELY TO REPAIR OR REPLACEMENT OF THE ITEMS SOLD OR REFUND OF THE PURCHASE PRICE PAID BY BUYER, AT SELLER'S SOLE OPTION. IN NO EVENT SHALL SELLER BE LIABLE FOR ANY INCIDENTAL, CONSEQUENTIAL OR SPECIAL DAMAGES OF ANY KIND OR NATURE WHATSOEVER, INCLUDING BUT NOT LIMITED TO LOST PROFITS ARISING FROM OR IN ANY WAY CONNECTED WITH THIS AGREEMENT OR ITEMS SOLD HEREUNDER, WHETHER ALLEGED TO ARISE FROM BREACH OF CONTRACT, EXPRESS OR IMPLIED WARRANTY, OR IN TORT, INCLUDING WITHOUT LIMITATION, NEGLIGENCE, FAILURE TO WARN OR STRICT LIABILITY.

6. Changes, Reschedules and Cancellations: Buyer may request to modify the designs or specifications for the items sold hereunder as well as the quantities and delivery dates thereof, or may request to cancel all or part of this order, however, no such requested modification or cancellation shall become part of the contract between Buyer and Seller unless accepted by Seller in a written amendment to this Agreement. Acceptance of any such requested modification or cancellation shall be at Seller's discretion, and shall be upon such terms and conditions as Seller may require.

7. Special Tooling: A tooling charge may be imposed for any special tooling, including without limitation, dies, fixtures, molds and patterns, acquired to manufacture items sold pursuant to this contract. Such special tooling shall be and remain Seller's property notwithstanding payment of any charges by Buyer. In no event will Buyer acquire any interest in apparatus belonging to Seller which is utilized in the manufacture of the items sold hereunder, even if such apparatus has been specially converted or adapted for such manufacture and notwithstanding any charges

paid by Buyer. Unless otherwise agreed, Seller shall have the right to alter, discard or otherwise dispose of any special tooling or other property in its sole discretion at any time.

8. Buyer's Property: Any designs, tools, patterns, materials, drawings, confidential information or equipment furnished by Buyer or any other items which become Buyer's property, may be considered obsolete and may be destroyed by Seller after two (2) consecutive years have elapsed without Buyer placing an order for the items which are manufactured using such property. Seller shall not be responsible for any loss or damage to such property while it is in Seller's possession or control.

9. Taxes: Unless otherwise indicated on the face hereof, all prices and charges are exclusive of excise, sales, use, property, occupational or like taxes which may be imposed by any taxing authority upon the manufacture, sale or delivery of the items sold hereunder. If any such taxes must be paid by Seller or if Seller is liable for the collection of such tax, the amount thereof shall be in addition to the amounts for the items sold. Buyer agrees to pay all such taxes or to reimburse Seller therefore upon receipt of its invoice. If Buyer claims exemption from any sales, use or other tax imposed by any taxing authority, Buyer shall save Seller harmless from and against any such tax, together with any interest or penalties thereon which may be assessed if the items are held to be taxable.

10. Indemnity For Infringement of Intellectual Property Rights: Seller shall have no liability for infringement of any patents, trademarks, copyrights, trade dress, trade secrets or similar rights except as provided in this Part 10. Seller will defend and indemnify Buyer against allegations of infringement of U.S. Patents, U.S. Trademarks, copyrights, trade dress and trade secrets (hereinafter 'Intellectual Property Rights'). Seller will defend at its expense and will pay the cost of any settlement or damages awarded in an action brought against Buyer based on an allegation that an item sold pursuant to this contract infringes the Intellectual Property Rights of a third party. Seller's obligation to defend and indemnify Buyer is contingent on Buyer notifying Seller within ten (10) days after Buyer becomes aware of such allegations of infringement, and Seller having sole control over the defense of any allegations or actions including all negotiations for settlement or compromise. If an item sold hereunder is subject to a claim that it infringes the Intellectual Property Rights of a third party, Seller may, at its sole expense and option, procure for Buyer the right to continue using said item, replace or modify said item so as to make it noninfringing, or offer to accept return of said item and return the purchase price less a reasonable allowance for depreciation. Notwithstanding the foregoing, Seller shall have no liability for claims of infringement based on information provided by Buyer, or directed to items delivered hereunder for which the designs are specified in whole or part by Buyer, or infringements resulting from the modification, combination or use in a system of any item sold hereunder. The foregoing provisions of this Part 10 shall constitute Seller's sole and exclusive liability and Buyer's sole and exclusive remedy for infringement of Intellectual Property Rights. If a claim is based on information provided by Buyer or if the design for an item delivered hereunder is specified in whole or in part by Buyer, Buyer shall defend and indemnify Seller for all costs, expenses or judgments resulting from any claim that such item infringes any patent, trademark, copyright, trade dress, trade secret or any similar right.

11. Force Majeure: Seller does not assume the risk of and shall not be liable for delay or failure to perform any of Seller's obligations by reason of circumstances beyond the reasonable control of Seller (hereinafter 'Events of Force Majeure'). Events of Force Majeure shall include without limitation, accidents, acts of God, strikes or labor disputes, acts, laws, rules or regulations of any government or government agency, fires, floods, delays or failures in delivery of carriers or suppliers, shortages of materials and any other cause beyond Seller's control.

12. Entire Agreement/Governing Law: The terms and conditions set forth herein, together with any amendments, modifications and any different terms or conditions expressly accepted by Seller in writing, shall constitute the entire Agreement concerning the items sold, and there are no oral or other representations or agreements which pertain thereto. This Agreement shall be governed in all respects by the law of the State of Ohio. No actions arising out of the sale of the items sold hereunder or this Agreement may be brought by either party more than two (2) years after the cause of action accrues.

9/91-P



Parker Hannifin Corporation
Hydraulic Valve Division
373 Meuse Avenue
Hicksville, Ohio, USA 43526
Tel: (419) 542-6611
Fax: (419) 542-8871
www.parker.com/hydraulicvalve

Bulletin HY14-2004-B1/US,
5C, 9/02, PHD