



Bulletin HY11-5715-697/UK

Operation Manual Series TDP/TEP

Design > 40



2-Way High-Response Valves

Parker Hannifin
Manufacturing Germany GmbH & Co. KG
Hydraulic Controls Division Europe
Gutenbergstr. 38
41564 Kaarst, Germany
Tel.: (+49) 181 99 44 43 0
E-mail: valveshcd@parker.com
Copyright © 2015, Parker Hannifin Corp.

**WARNING — USER RESPONSIBILITY**

FAILURE OR IMPROPER SELECTION OR IMPROPER USE OF THE PRODUCTS DESCRIBED HEREIN OR RELATED ITEMS CAN CAUSE DEATH, PERSONAL INJURY AND PROPERTY DAMAGE.

This document and other information from Parker-Hannifin Corporation, its subsidiaries and authorized distributors provide product or system options for further investigation by users having technical expertise.

The user, through its own analysis and testing, is solely responsible for making the final selection of the system and components and assuring that all performance, endurance, maintenance, safety and warning requirements of the application are met. The user must analyze all aspects of the application, follow applicable industry standards, and follow the information concerning the product in the current product catalog and in any other materials provided from Parker or its subsidiaries or authorized distributors.

To the extent that Parker or its subsidiaries or authorized distributors provide component or system options based upon data or specifications provided by the user, the user is responsible for determining that such data and specifications are suitable and sufficient for all applications and reasonably foreseeable uses of the components or systems.

Offer of Sale

Please contact your Parker representation for a detailed "Offer of Sale".

Content	Page
1. Introduction	4
Characteristics of Valve Driver	4
Order Code TDP	5
Order Code TEP	5
Technical Data	6
Block Diagram of Integral Electronics	7
2. Safety Instructions	8
Symbols	8
Service	8
3. Important Details	8
Intended Usage	8
Common Instructions	8
Liability	8
Storage	8
4. Mounting / Installation	9
Scope of Supply	9
Mounting	9
Available Bolts Kits	9
Limits of Use	9
Pressure Fluids	9
Electrical Connection	10
Electrical Interfacing	11
5. Operation Instructions	13
Solenoid Current Monitoring	13
ProPxD Parameterizing Software	13
Shut-off Valve TEP	14
Air Bleeding of Hydraulic System	20
Filter	20
Flushing	20
6. Troubleshooting	20
7. Accessories / Spare Parts	21
Accessories	21
Spare Parts	21

Operation Manual

1. Introduction

Parker 2-way high-response valves have an integral electronics and require only one sole electrical common for the control system. Different flow sizes are available to achieve an optimal adaption for different applications.

Series TEP base on the TDP range. Additionally, TEP valves are equipped with a direction control valve for shutting off the pilot system.

Characteristics of Valve Driver

The described integral electronic driver combines all necessary functions for the optimal operation of the valves. Thanks to its excellent dynamic the valves are usable within closed loop control applications. The most important features are:

- high dynamic actuator principle with special designed electronic driver
- closed loop controlled spool position
- constant current actuator control with overcurrent shutoff
- excellent properties for response sensitivity and temperature drift
- differential input stage with various command signal options
- diagnostic output for spool stroke
- standard central connection
- compatible to the relevant European EMC-standards

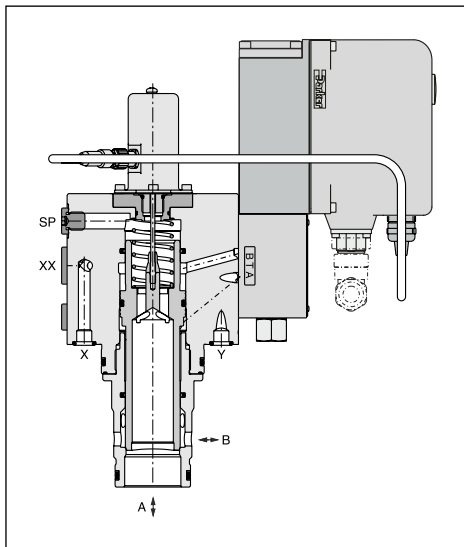

TDP

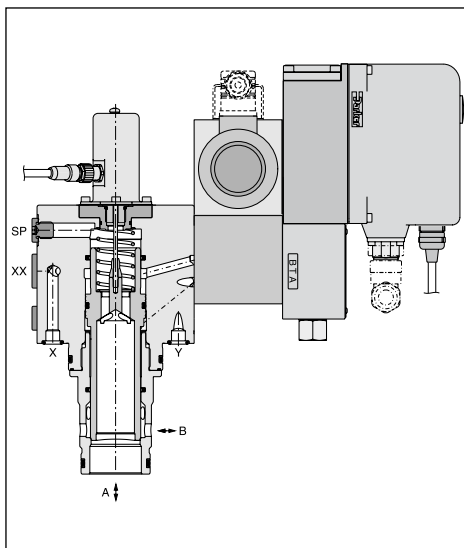

TEP

Ordering code

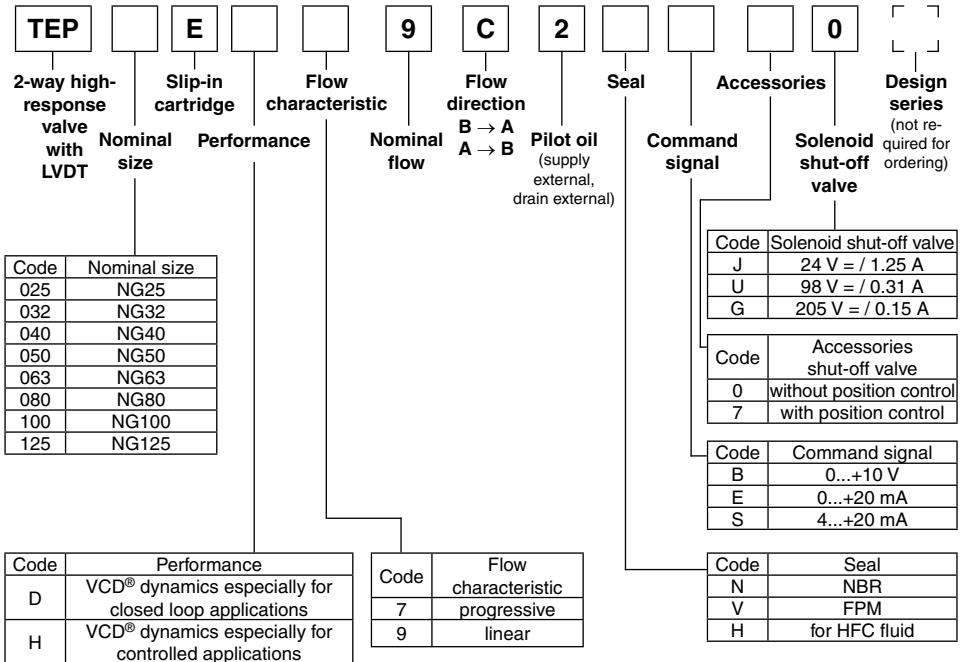
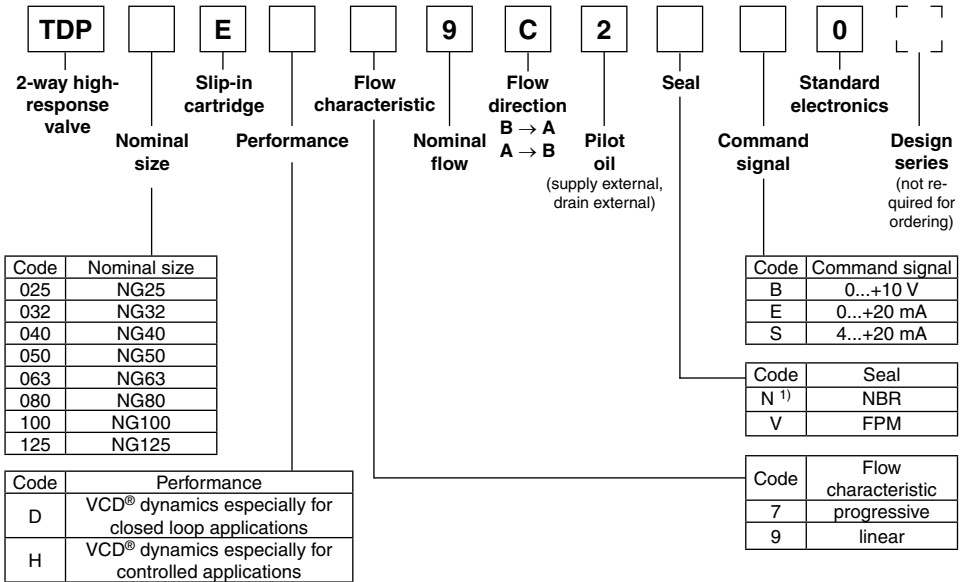

¹⁾ For HFC fluids suitable

Please order connector separately.
Angle female connector must be used for NG25 to NG50.

Technical data

General									
Design	Proportional throttle valve, slip-in cartridge according to ISO 7368 (except for size NG125)								
Nominal size	DIN	NG25	NG32	NG40	NG50	NG63	NG80	NG100	NG125
Mounting position	unrestricted								
Ambient temperature	[°C]	-20...+50							
Weight	[kg]	11	13	15	26	52	105	157	193
MTTF _D value ¹⁾	[years]	75							
Vibration resistance	[g]	10 sinus 5...2000 Hz acc. IEC 68-2-6 30 random noise 20...2000 Hz acc. IEC 68-2-36 15 shock acc. IEC 68-2-27							
Hydraulic									
Max. operating pressure	[bar]	Ports A, B, X, SP up to 350, XX observe accumulator pressure rating, port Y max. 35							
Fluid	Hydraulic oil according to DIN 51524								
Fluid temperature	[°C]	-20 ... +60 (NBR: -25...+60)							
Viscosity recommended	[cSt] / [mm ² /s]	30 ... 80							
permitted	[cSt] / [mm ² /s]	20 ... 400							
Filtration	ISO 4406 (1999); 18/16/13								
Nominal flow at Δp=5 bar (linear)	[l/min]	420	850	1500	1900	3600	4500	8000	11500
Recommended max. flow (linear)	[l/min]	800	2000	3000	4500	8000	13000	20000	29000
Nominal flow at Δp=5 bar (progressive)	[l/min]	380	750	1300	1700	3200	3900	6800	9200
Recommended max. flow (progressive)	[l/min]	700	1750	2600	4000	7000	11250	17000	23000
Flow direction	B to A and A to B								
Pilot pressure	[bar]	must be as high as system pressure							
Pilot oil supply	external via X								
drain	external via Y								
Leakage in pilot valve at 100 bar	[ml/min]	<400							
Pilot valve size	NG06				NG10				
Max. pilot flow at 140 bar pilot press.	[l/min]	23	30	40	40	70	80	100	100
Static/dynamic									
(for optimal dynamics see installation recommendation in main catalogue)									
Step response at pilot press. >140 bar	[ms]	10.5	12	14	20	17	23	28	46
Frequency response at pilot press. >140 bar									
Amplitude -3 dB; 10 % ±5 %	[Hz]	95	80	74	66	52	46	41	23
Phase -90°; 10 % +5 %	[Hz]	85	63	59	52	56	51	47	45
Hysteresis	[%]	< 0.1							
Sensitivity	[%]	< 0.05							
Temperature drift	[%/K]	< 0.025							

¹⁾ If valves with onboard electronics are used in safety-related parts of control systems, in case the safety function is requested, the valve electronics voltage supply is to be switched off by a suitable switching element with sufficient reliability.

Technical data

Electrical		
Duty ratio	[%]	100
Protection class		IP65 in acc. with EN 60529 (with correctly mounted plug-in connector)
Supply voltage / ripple	[V]	22...30, electric shut-off at <19, ripple < 5 % eff., surge free
Current consumption max.	[A]	3.5
Pre-fusing	[A]	4.0 medium lag
Input signal		
Code B Voltage	[V]	0...+10, ripple < 0.01 % eff., surge free
Impedance	[kOhm]	100
Code E Current	[mA]	0...+20, ripple < 0.01 % eff., surge free
Impedance	[Ohm]	< 250
Code S Current	[mA]	4...20, ripple < 0.01 % eff., surge free
Impedance	[Ohm]	< 250
Differential input max.	[V]	30 for terminal D and E against PE (terminal G) 11 for terminal D and E against 0V (terminal B)
Enable signal	[V]	5...30, Ri = 9 kOhm
Diagnostic signal	[V]	0...+10 / +12.5 error detection, rated max. 5 mA
EMC		EN 61000-6-2, EN 61000-6-4
Electrical connection		6 + PE acc. EN 175201-804
Wiring min.	[mm ²]	7 x 1.0 (AWG16) overall braid shield
Wiring lenght max.	[m]	50

Block diagram of integrated electronics

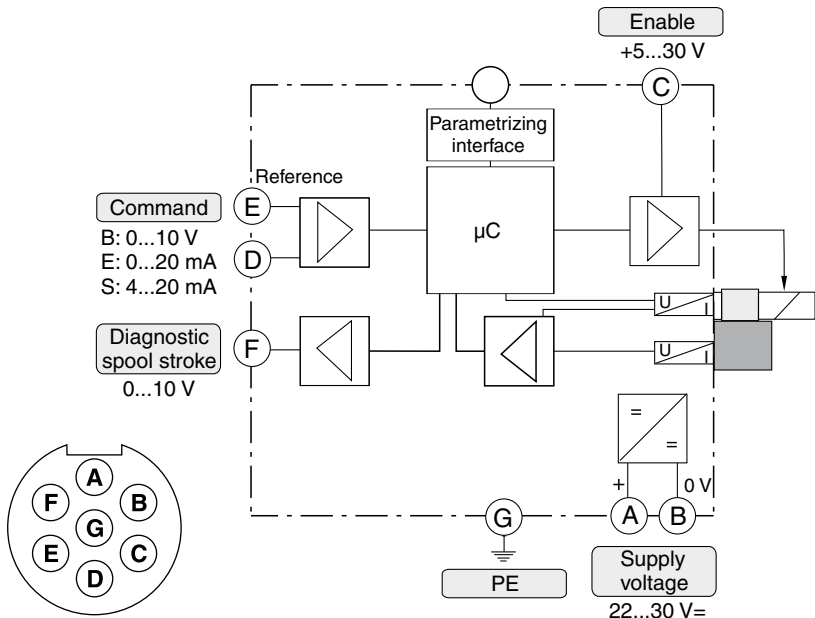

2. Safety Instructions

Please read the operation manual before installation, startup, service, repair or stocking! Paying no attention may result in damaging the valve or incorporated system parts.

Symbols

This manual uses symbols which have to be followed accordingly:



Instructions with regard to the warranty



Instructions with regard to possible damaging of the valve or linked system components



Helpful additional instructions

Service

Workings in the area of installation, commissioning, maintenance and repair of the valve may only be allowed by qualified personnel. This means persons which have, because of education, experience and instruction, sufficient knowledge on relevant directives and approved technical rules.

3. Important Details

Intended Usage

This operation manual is valid for 2-way high-response valves series TDP*D/H and TEP*D/H. Any different or beyond it usage is deemed to be as not intended. The manufacturer is not liable for warranty claims resulting from this.

Common Instructions

We reserve the right for technical modifications of the described product. Illustrations and drawings within this manual are simplified representations. Due to further development, improvement and modification of the product the illustrations might not match precisely with the described valve. The technical specifications and dimensions are not binding. No claim may resulting out of it. Copyrights are reserved.

Liability

The manufacturer does not assume liability for damage due to the following failures:

- incorrect mounting / installation
- improper handling
- lack of maintenance
- operation outside the specifications



Do not disassemble the valve! In case of suspicion for a defect please contact Parker.

Storage

In case of temporary storage the valve must be protected against contamination, atmospheric exposure and mechanical damages. Each valve has been factory tested with hydraulic oil, resulting in protection of the core parts against corrosion. Yet this protection is only ensured under the following conditions:

Storage period	Storage requirements
12 months	constant humidity < 60 % as well as constant temperature < 25 °C
6 months	varying humidity as well as varying temperature < 35 °C



Outdoor storage or within sea and tropical climate will lead to corrosion and might disable the valve!

Operation Manual

4. Mounting / Installation

Scope of Supply

Please check immediately after receiving the valve, if the content is matching with the specified scope of supply. The delivery includes:

- valve
- operation manual

The central connector has to be ordered separately and is not included in the delivery.

 Please check the delivery immediately after receiving the shipment for apparent damages due to shipping. Report shipment losses at once to the carrier and the supplier!

Mounting

- Compare valve type (located on the name plate) with part list resp. circuit diagram.
- The valve may be mounted fix or movable in any direction.
- Verify the mounting surface for the valve. Unevenness of 0.01 mm/100 mm, surface finish of 6.3 µm are tolerable values.

 Keep valve mounting surface and work environment clean!

Available Bolt Kits

Size	Ordering no.	Mounting bolt	Torque
TDP/TEP025	BK504	4 pcs. M12x100	108 Nm
TDP/TEP032	BK529	4 pcs. M16x100	264 Nm
TDP/TEP040	BK481	4 pcs. M20x110	517 Nm
TDP/TEP050	BK481	4 pcs. M20x110	517 Nm
TDP/TEP063	BK518	4 pcs. M30x160	1775 Nm
TDP/TEP080	BK530	8 pcs. M24x160	890 Nm
TDP/TEP100	BK531	8 pcs. M30x150	1775 Nm
TDP/TEP125	BK537	8 pcs. M36x180	3100 Nm

Pressure Fluids

The following rules applies for the operation with various pressure fluids:

 This information serves for orientation and does not substitute user tests among the particular operating conditions. Particularly no liability for media compatibility may be derived out of it.

Mineral oil: usable without restriction.
HFC: choose the right seal option for series TEP.
Choose seal option code N for series TDP.

- Remove protection plate from the valve mounting surface
- Check the proper position of the valve ports and the O-rings.
- Mounting bolts: use property class 12.9, ISO 4762

 Insufficient condition of the valve mounting surface might create malfunction!
Incorrect mounting resp. bolt torque may result in abrupt leakage of hydraulic fluid on the valve ports.

 Y-port has always to be tied directly and separately to tank!

Limits of Use

The valve may be operated within the determined limits only. Please refer to the "technical data" section as well as to the "characteristic curves" in the Parker catalogue HY11-3500/UK "Hydraulic Valves Industrial Standard".

 Follow the environmental conditions! Unallowable temperatures, shock load, aggressive chemicals exposure, radiation exposure, illegal electromagnetic emissions may result in operating trouble and may lead to failure! Follow the operating limits listed in the "specifications" table!

For operation with the following pressure fluids please consult Parker:

HFA	Oil-in-water emulsion
HFB	Water-in-oil emulsion
HFD	Unhydrous fluids (Phosphor-Ester)

 For detailed information concerning pressure fluids note VDMA-document 24317 as well as DIN 51524 & 51502.

Special gaskets may be available depending on the utilized fluid.

In case of doubt please consult Parker.

Operation Manual

Electrical Connection

The electrical connection of the valve takes place by one common cable, which is coupled to the integrated electronic driver by a central connector assembly.

The connection requires a 6 + PE female connector EN 175201-804.

Female connector (ordering no. 5004072)

For NG63 up to NG125

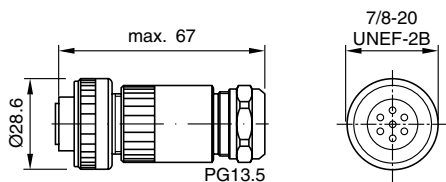

Angled female connector (ordering no. 5005160)

For NG25 up to NG50

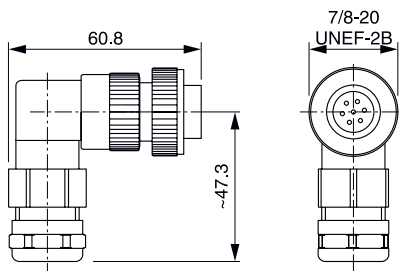

The connecting cable has to comply to the following specification:

Cable type	control cable, flexible, 7 conductors, overall braid shield
Cross section	min. AWG16
Outer dimension	8...12 mm
Cable length	max. 50 m

☞ For cable lengths > 50 m consult factory.

The connection cable is coupled to the female connector by solder joints.

Stripping lengths for the connecting cable:

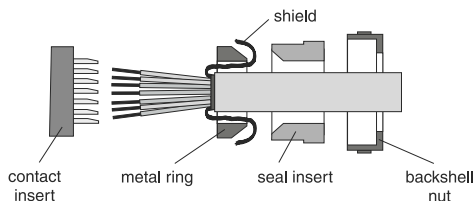
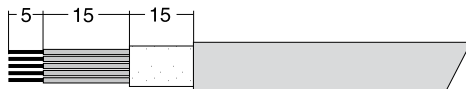

⚠ A female connector with metal housing is required! Plastic made models may create function problems due to insufficient EMC-characteristics.

⚠ Do not disconnect cable socket under tension!

The backshell nut of the cable gland has to be tightened with a suitable tool. The target value for the tightening torque is 4 Nm. Tighten the cap nut with a torque of 5 Nm after attaching the female connector on the socket.

⚠ Incomplete tightening of backshell nut respectively cap nut may result in undesired release of the connection as well as degradation of the water tightness.

When using female connectors of other manufacturers, the relevant regulations must be observed.

⚠ The cable may only be connected to the female connector by authorized and qualified personnel. A short between individual conductors resp. to the connector housing, bad soldering as well as improper shield connection may result in malfunction and breakdown of the valve.

⚠ The mounting surface of the valve has to be connected to the earth grounded machine frame. The earth ground wire from the valve connecting cable as well as the cable shield have to be tied to the protective earth terminal within the control unit. It is necessary to use a low ohmic potential connection between control unit and machine frame to prevent earth loops (cross section AWG 6).

Electrical Interfacing

Supply Voltage

The supply voltage for the valve has to cover the range of 22...30 V. Valve is de-energized below 19 V. The residual ripple may not exceed 5 % eff.

⚠ The applied power supply must comply to the relevant regulations (DIN EN 61558) and must carry a CE-mark. The operating voltage for the valve must be free of inductive surges. Do not exceed the max. value of 30 V! Higher voltage can lead to failure of the valve.

⚠ The increased inrush current of the valve should be considered when selecting the power supply. A stabilized power supply with overcurrent limiting feature should not be used. Due to the inrush current of the valve the current limit circuit may respond prematurely and create problems during energizing of the supply voltage.

⚠ The operation of the valve is blocked if the supply voltage polarity is interchanged.

⚠ Each valve requires a separate pre-fuse of 4 Amp semi time-lag. Failure to observe this instruction may create irreparable damage of valve respectively incorporated system parts.

Wiring diagram of supply voltage

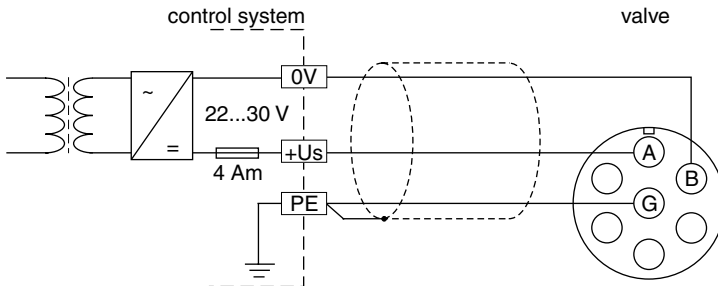

Operation Manual

Enable input

A signal voltage enables the actuator drive of the valve. Continuous operation of the valve requires a permanent voltage 5...30 V (i.e. the supply voltage). In case of disabling the signal the valve will reach its power down position spring-actuated independently from the command signal value.

 The enable function represents no safety arrangement against unwanted valve operation in terms of rules for accident prevention!

Command signal input

The spool stroke behaves proportional to the command signal amplitude.

 The command input signal needs to be filtered as well as free of inductive surges and modulations. Due to the sensitivity of the valve a high signal quality is recommended, this will prevent malfunction.

 The option 4...20 mA uses the “3.6 mA“ condition as breakdown-information. If the input signal line is interrupted, an evaluable failure information is available. In this case the actuator drive will be switched off. The drive will switch on when the input signal reaches a value of 3.8 mA, it switches off when the command falls below 3.6 mA. This determination follows the NAMUR-specification NE43.

Diagnostics output

A diagnostics signal is available. Its voltage represents the operating condition of the valve.

 The output may drive a load of max. 5 mA. Exceeding of this limit leads to malfunction.

Valves NG25 to NG50

Code command signal	Command signal	VCD actuator	Diagnostic signal
B	0...+10 V	on	0...+10 V
	0...-10 V	on	0...-10 V
	Overload	off	12.5 V
E	0...+20 mA	on	0...+10 V
	0...-20 mA	on	0...-10 V
	Overload	off	12.5 V
K	0...+10 V	on	0...-10 V
	0...-10 V	on	0...+10 V
	Overload	off	12.5 V
S	4...12 mA	on	0...-10 V
	12...20 mA	on	0...+10 V
	0...3.6 mA	off	Cable break, 12.5 V
	Overload	off	12.5 V

Valves NG63 to NG125

Code command signal	Command signal	VCD actuator	Diagnostic signal
B	0...+10 V	on	0...-10 V
	0...-10 V	on	0...+10 V
	Overload	off	12.5 V
E	0...+20 mA	on	0...-10 V
	0...-20 mA	on	0...+10 V
	Overload	off	12.5 V
K	0...+10 V	on	0...+10 V
	0...-10 V	on	0...-10 V
	Overload	off	12.5 V
S	4...12 mA	on	0...+10 V
	12...20 mA	on	0...-10 V
	0...3.6 mA	off	Cable break, 12.5 V
	Overload	off	12.5 V

Operation Manual

5. Operating Instructions

 Supply pressure must be ensured before valve is energized.

Switch on/off series TEP

 When switching on the complete valve, the D3DW shut-off valve has to be switched at least 50 ms before enable of the DFplus pilot valve. When switching off, this order must be reversed. If this is not observed, vibrations can occur in the main stage.

Solenoid Current Monitoring

If the actuator current time interval exceeds 10 seconds, the actuator is switched off to prevent overheating. For normal operating conditions this state will not be reached, but it may occur with a contaminated sluggish valve.

 In this case the reason for the contamination should be repaired (hydraulic fluid exchange, filtration review, valve flushing).

The overcurrent shutoff condition may be reset by temporary disconnection of the enable signal.

 The shutoff of the VCD actuator due to overload will be indicated via the diagnostics output.

ProPxD parameterizing software

The ProPxD software permits comfortable parameter setting for the module electronic. Via the clearly arranged entry mask the parameters can be noticed and modified. Storage of complete parameter sets is possible as well as printout or record as a text file for further documentation.

The PC software can be downloaded free of charge at www.parker.com/euro_hcd - see page "Support" or directly at www.parker.com/propxd.

Please check periodical for updates.

Hardware requirements

- PC with operating system from Windows® XP upwards
- interface RS232C
- display resolution min. 800 x 600
- connection cable between PC and electronic module
- storage requirement approx. 40 MB

 If your PC has no serial interface according to RS232 standard you require in addition an USB-RS232C adapter.

Cable Specification

 Attention! The valve electronic provides no USB interface, but can only be parameterized via an RS232C connection. Therefore the usage of USB standard cables is not allowed and may result in damaging of valve resp. PC.

Parametrizing

Ordering code: 40982923



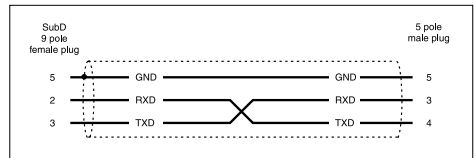

PC side connection

valve side connection

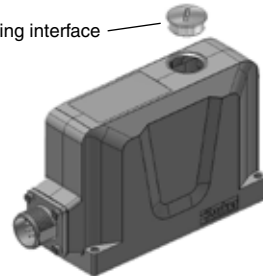

Plug for parameterizing interface



 The cover plug has to be re-installed after completion of the parametrizing work.

Shut-off valve TEP

Product name D3DW

CE mark

The CE mark appears on the main nameplate. If the product is installed as part of a larger machine, this larger machine is in turn subject to EU directives and must therefore obtain a general CE mark for the machine as a whole. The machine must not enter circulation in the EU until this is done.

Conformity

The declaration of conformity (see page 17) attests that the products comply with all essential health and safety requirements set out in Annex I of the Machinery Directive 2006/42/EC.

☞ If our product is used in ways other than specified, hazards may occur that could not be foreseen by the manufacturer. Any resulting loss or damage is not the responsibility of Parker Hannifin.

☞ If the described product is installed in a machine that came into circulation before 1995, note the following:
If the function has not been changed significantly, commissioning may not take place until conformity with national occupational health and safety provisions has been established for the machine as a whole, in particular those provisions implementing the Use of Work Equipment Directive.
If the function has been changed significantly, a new conformity procedure must be carried out in accordance with the Machinery Directive 2006/42/EC.

Electronic control system

The D3DW valve must be operated by the user with a suitable control system.

The valve is connected using separate wires for solenoids/position control.

Solenoid connection

Each solenoid connection requires one plug 2 + PE as specified in EN 175301-803.

Connection of plug

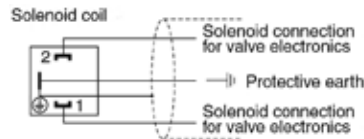

☞ The plug for the solenoid must be ordered separately.

Deliverable version

Thread	Colour	Mark	Order no.
PG9	grey	A	5001711
PG11	grey	A	5001717

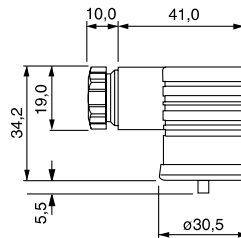

The wiring must meet the following specifications:

Type	Flexible control cable, 3-core
Size	Min. 1.5 mm ²
External diameter	PG9: 4.5...7 mm PG11: 6...9 mm
Length	Max. 50 m

☞ For lengths >50 m please contact Parker. The sealing surface of the valve must be properly connected to the earthed frame of the machine. Connect the earth wire and cable shield to the protective earth in the electrical cabinet.

Use the screw connectors to attach the wires to the plug. Use a suitable tool to tighten the screw at the cable entry point.

Operation Manual

 Failure to tighten the screw connectors may cause the connectors to loosen and may impair the seal.

If you are using plugs from other manufacturers, follow the relevant instructions.

 Short circuits between the wires, poor workmanship or incorrect attachment of the shielding may cause disruption and the failure of the valve and the electronic control system.

Sensor connection

See "Technical data" page 18

Choice of solenoid

The choice of a suitable solenoid is an important factor in the operational reliability of the valve. The D3DW is available with various solenoid voltages. If the solenoid can be adjusted by setting parameters in the electronic control system, the suitable solenoid options must be selected.

 Note about using valves with actuating solenoids:

The current drops as the solenoid heats up. The lower current has no effect on valve operation, provided the specified voltage is maintained at the valve.

 A suitable tool must if necessary be used for manual emergency actuation of the solenoid.

Remaining risk

Allergic reactions

Hydraulic oil can cause allergic reactions on susceptible skin. This can be prevented by taking the precautions that are usual when handling mineral oil products and by using personal protective equipment.

Leaking plugs

 Leaking plugs can cause a malfunction. That is why the plugs must be checked for leaks at the regular maintenance interval. Leaking plugs may constitute a safety hazard, so the valve must be returned to the manufacturer for repair.

Lightning

 If electronic components are exposed to electromagnetic fields as a result of lightning, they must be checked to ensure they are still working perfectly. If there is a malfunction, the product must be returned to the manufacturer.

Temperature

The surface of our product may heat up in use.

 The service temperatures may exceed the temperature threshold for burn injury, 70 °C. Above this threshold, even brief contact with the surface may result in a burn.

The only way to consistently prevent burn injuries is to use personal protective equipment and to remain safety-conscious at all times.

 If integrated electronics are exposed to a temperature above 80 °C, they may malfunction.

Power failure

 In a power failure the valve piston returns to the spring centred starting position.

You must check whether this creates potential hazards when the system/machine is used.

Hydraulic

The D3DW is tested and approved with an even flow. If the flow becomes asymmetrical, the safety function of the valve may be compromised. You should therefore carry out tests before commissioning to verify that the valve is in good working order. If the valve piston has been under pressure and stationary in the end position for an extended period, oil particles may cause the piston to seize. For this reason the valve should be actuated regularly.

Electrical connection for position control

The position control can be connected as normally closed or normally open. In principle, we recommend a normally closed connection, as this is the only way to ensure that position control works properly

Correct use

Our products are manufactured using state of the art technology and recognised safety procedures.

The D3DW is designed for mould closing devices in injection moulding machines according to the manufacturer's installation instructions (see page 19).

According to section 1(2b) of accident prevention guidelines "Injection moulding machines" (VGB 7 ac) and section 5 of EN 201:1997 "Injection moulding machines. Safety requirements", the valves must be independently monitored by the control system of the injection moulding machine, such that if position control fails, a new machine cycle is prevented from starting.

Function

The D3DW is devised that influence the direction of a flow. To do this, connections between the various ports are made or broken. Activating the solenoid or the hydraulic pilot causes the piston in the valve to move to the end position.

If the electrical signal is removed, the installed spring pushes the piston back to its starting position.

The purpose of the installed position control is to detect when the piston is in the starting position.

Electrical connections

Before commissioning,

- all electrical connections must be made professionally, using suitable ducting,
- parts of the machine and individually installed components must be adequately earthed,
- all limit switches and control elements must be properly integrated with the control system.

Hydraulic requirements for pilot operated directional control valves

To guarantee that the main piston operates reliably at all times, the minimum pilot pressure must be provided. To achieve this, a suitable combination of flow and return arrangements must be selected for the pilot oil.

Other documentation

Other applicable standards / rules

- 2006/42/EC
Machinery Directive
- 2006/95/EC
Low Voltage Directive
- ISO 4406:1999-12
Hydraulic fluid power - Fluids - Method for coding the level of contamination by solid particles
- ISO 4401:2005-07
Hydraulic valves; mounting surfaces and connecting plates
- EN 201:1997 / section 5
Rubber and plastics machines - Injection moulding machines - Safety requirements
- DIN EN 626-1:2008-09
Safety of machinery - Reduction of risks to health from hazardous substances emitted by machinery -
Part 1: Principles and specifications for machinery manufacturers
- DIN EN 60204-1; VDE 0113-1:2007-06
Safety of machinery – Electrical equipment of machines – Part 1: General requirements
- DIN EN 60529; VDE 0470-1:2000-09
Degrees of protection provided by enclosures (IP code)
- DIN EN 61000-4-2/3/4/6/8
Electromagnetic compatibility
- DIN 51524-1:2006-04
Pressure fluids - HLP hydraulic oils -
Part 1: Minimum requirements
- DIN 51525-2:2006-04
Pressure fluids - HLP hydraulic oils -
Part 2: Minimum requirements
- German Occupation Safety Ordinance (Betriebssicherheitsverordnung)
- German Labour Protection Act (Arbeitsschutzgesetz)

Declaration of Conformity

EC Declaration of Conformity / Translation from German
2006/42/EC



Parker Hannifin
Manufacturing Germany GmbH & Co. KG
Hydraulic Controls Division Europe
Gutenbergstrasse 38
41564 Kaarst, Germany

Mr Günther Funk is authorised to compile the technical file.
For enquiries, see the company address.

Parker Hannifin Manufacturing Germany GmbH & Co. KG declares that the safety valves

Directly operated directional control valves NG6 with solenoid actuation and monitoring of starting position Code I4N or I5N
Type D1VW*-SC/D1DW*-SC

Directly operated directional control valves NG10 with solenoid actuation and monitoring of starting position Code I4N or I5N
Type D3W*-SC/D3DW*-SC

Directly operated directional control valves NG10 with solenoid actuation and monitoring of starting position Code I4N, I5N or I6N
Type D31DW*-SC

Directly operated directional control valves NG16 with solenoid actuation and monitoring of starting position Code I4N, I5N or I6N
Type D41VW*-SC

Directly operated directional control valves NG25 with solenoid actuation and monitoring of starting position Code I4N, I5N or I6N
Type D81VW*-SC/D91VW*-SC

fulfil all the relevant provisions of the

Machinery Directive 2006/42/EC

This conformity has been established on the basis of type testing by

Prüf- und Zertifizierungsstelle
Fachausschuss MHHW
Graf-Recke-Strasse 69
40239 Düsseldorf

(ID 0393)

Certificate no. MHHW 09061 (NG6), MHHW 09062 (NG10 - Directly operated).
MHHW 09063 (NG10 - Pilot operated), MHHW 09064 (NG16, NG25)

Harmonised standards applied:

EN 201:1997 / section 5 Rubber and plastics machines - Injection moulding machines - Safety requirements
DIN EN 60529:2000-09 Degrees of protection provided by enclosures (IP code)
DIN EN 61000-4-2/3/4/6/8 Electromagnetic compatibility

Place, Date: Kaarst, 01.07.2011

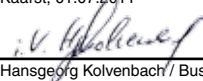
Signature: 
The undersigned: Hansgeorg Kolvenbach / Business Unit Manager Industrial Valves

 Any unauthorised structural change or addition to the product may jeopardise safety to an

unacceptable degree. This would invalidate the declaration of conformity supplied with the product.



Position control switch

Technical data

Supply voltage range	18 ... 42 VDC
Supply ripple	≤10 %
No-load power consumption	≤30 mA
Max. output current per channel, ohmic load	400 mA
Min. output load per channel, ohmic load	100 kOhm
Max. output drop at 0.2 A	≤1.1 V
Max. output drop at 0.4 A	≤1.6 V
Switching hysteresis	≤0.1 mm
Ambient temperature range	0...50 °C
Max. ambient field strength at 50 Hz	1200 A/m
Protection class	IP65
Socket	M12 to IEC 61076-2-101

The factory setting of the position control switch must not be changed.

Notes on installation

- Connections to the limit switch must be laid separately from mains connections, for example power supplies to motors or magnets, because inductive voltage peaks would otherwise pass via the supply network to the limit switch, which could be damaged even though a protection circuit is installed.
- A suitable DC power supply is required for the switch. The ripple of the power supply must not exceed 10 %.
- Voltage spikes occurring when inductive loads are removed should be eliminated using a suitable protection circuit, for example flyback diodes.
- A built-in overload protection circuit suspends the switching function of the limit switch if an overload occurs. When the overload ends, the limit switch automatically resumes operation.
- The limit switch must not be installed close to AC consumers, e.g. AC solenoids, which may cause disruption. A minimum distance of 0.1 m must be observed in all cases.
- The product may only be operated in the conditions set out in the technical data.
- Connections must follow the connection list.

Connection Diagram

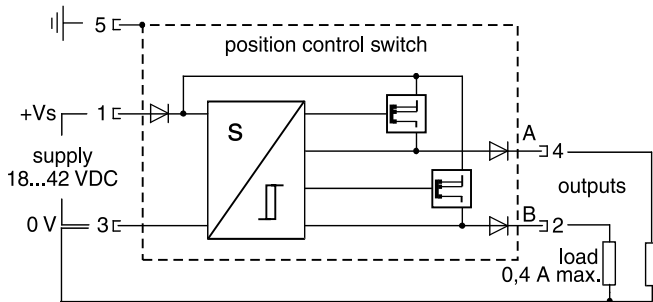

Limit switch type ASEW001D10

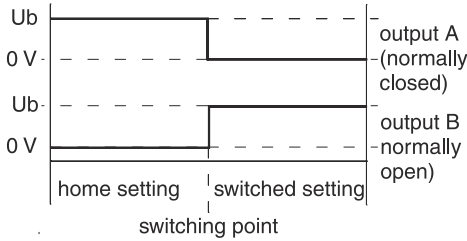

This switch is used to monitor **one** switching point. When the switching point is reached, exit A (port 4) closes, which corresponds to the normally closed type. Meanwhile, exit B (port 2) changes to the flow state, which corresponds to the normally open type.

Wirings

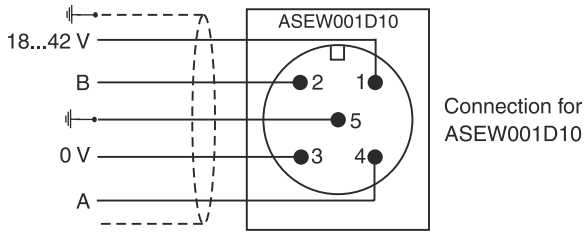

Installation

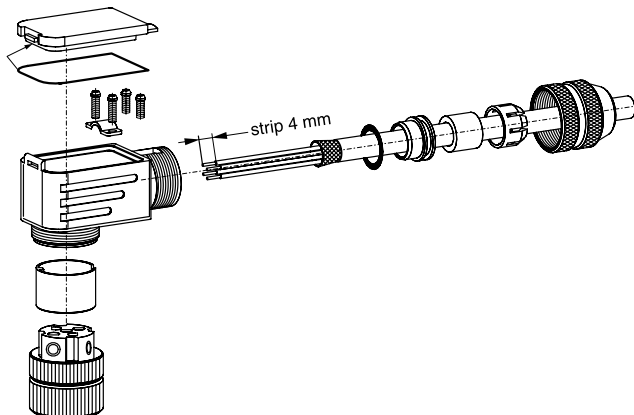

Operation Manual

Air Bleeding of Hydraulic System

During initial startup, after an oil change as well as after the opening of lines or valves the hydraulic system must be air bled.

Filter

The function and lifetime of the valve are strongly affected by the cleanliness of the fluid.

Purity level class of 18/16/13 acc. ISO4406 is required.

Flushing

It is recommended to flush the pipelines by short circuiting the pressure and return lines. This prevents the installation dirt from entering the valve.

6. Troubleshooting

Basis of troubleshooting is always a systematic approach.

 For suspect of a sluggish spool the valve may be flushed with clean pressure fluid.

 Troubleshooting in a hydraulic system requires detailed knowledge about function and construction of the system. Therefore the work may exclusively be performed by qualified personnel.

malfunction at hydraulic load runtime							
						- generally no function	
						- high frequent oscillation	
						- low frequent oscillation	
						- speed variations at unchanging command	
						- different speeds depending on travel direction	
						- speed too low	
						- drifting without command	
						possible reasons for malfunction	corrective actions
X						hydraulic pump resp. motor defective	replace hydraulic pump resp. motor
X	X	X	X	X		drive overloaded	reduce pressure resp. speed, increase valve size
X	X	X	X	X	X	valve contaminated	clean pressure fluid, filter / flush valve
		X	X			hydraulic fluid too viscous / too cold	change fluid grade, provide operational temperature
X	X					too low oil level within tank	refill pressure fluid
		X	X	X		filter contaminated	clean resp. replace filter
X	X			X	X	supply voltage too low	keep supply voltage range
	X					supply voltage carries too much ripple	reduce ripple
X				X		command signal too low	increase command signal
	X					command signal carries too much ripple	reduce ripple
			X			center position adjustment incorrect	check center position adjustment
X	X	X	X	X	X	contacts of central connector contaminated	clean contacts / replace plug
X						feed cable interrupted	fix feed cable
X	X	X	X	X	X	wiring sequence incorrect	correct wiring sequence
X					X	feed cable without shielding	change cable grade

7. Accessories

The following accessories are available for the valve series TDP*H:

Female connector 6+PE ordering code 5004072

Mounting bolts see table on page 9.

Spare parts / seal kits**TDP**

Size	NBR	FPM
TDP025	SK-TDP025EN30	SK-TDP025EV30
TDP032	SK-TDP032EN30	SK-TDP032EV30
TDP040	SK-TDP040EN30	SK-TDP040EV30
TDP050	SK-TDP050EN30	SK-TDP050EV30
TDP063	SK-TDP063EN30	SK-TDP063EV30
TDP080	SK-TDP080EN30	SK-TDP080EV30
TDP100	SK-TDP100EN30	SK-TDP100EV30
TDP125	SK-TDP125EN30	SK-TDP125EV30

TEP

Size	NBR	FPM
TEP025	SK-TEP025EN30	SK-TEP025EV30
TEP032	SK-TEP032EN30	SK-TEP032EV30
TEP040	SK-TEP040EN30	SK-TEP040EV30
TEP050	SK-TEP050EN30	SK-TEP050EV30
TEP063	SK-TEP063EN30	SK-TEP063EV30
TEP080	SK-TEP080EN30	SK-TEP080EV30
TEP100	SK-TEP100EN30	SK-TEP100EV30
TEP125	SK-TEP125EN30	SK-TEP125EV30

Please direct technical product enquiries to:

**Parker Hannifin
Manufacturing Germany GmbH & Co. KG**

Hydraulic Controls Division Europe

Gutenbergstr. 38

41564 Kaarst, Germany

Tel.: (+49) 181 99 44 43 0

E-mail: valveshcd@parker.com

**Hotline in Europe
Tel.: 00800-2727-5374**

