



Bulletin HY11-5715-653/UK

Operation Manual Series TPO

Design \geq 40



3-Way High-Response Valve

Parker Hannifin
Manufacturing Germany GmbH & Co. KG
Hydraulic Controls Division Europe
Gutenbergstr. 38
41564 Kaarst, Germany
Tel.: (+49) 181 99 44 43 0
E-mail: valveshcd@parker.com
Copyright © 2015, Parker Hannifin Corp.



WARNING — USER RESPONSIBILITY

FAILURE OR IMPROPER SELECTION OR IMPROPER USE OF THE PRODUCTS DESCRIBED HEREIN OR RELATED ITEMS CAN CAUSE DEATH, PERSONAL INJURY AND PROPERTY DAMAGE.

This document and other information from Parker-Hannifin Corporation, its subsidiaries and authorized distributors provide product or system options for further investigation by users having technical expertise.

The user, through its own analysis and testing, is solely responsible for making the final selection of the system and components and assuring that all performance, endurance, maintenance, safety and warning requirements of the application are met. The user must analyze all aspects of the application, follow applicable industry standards, and follow the information concerning the product in the current product catalog and in any other materials provided from Parker or its subsidiaries or authorized distributors.

To the extent that Parker or its subsidiaries or authorized distributors provide component or system options based upon data or specifications provided by the user, the user is responsible for determining that such data and specifications are suitable and sufficient for all applications and reasonably foreseeable uses of the components or systems.

Offer of Sale

Please contact your Parker representation for a detailed "Offer of Sale".

Content	Page
1. Introduction	4
Characteristics of Valve Driver	4
Order Code	4
Block Diagram of Integral Electronics	5
Technical Data	6
2. Safety Instructions	7
Symbols	7
Work at the Valve	7
3. Important Details	7
Intended Usage	7
Common Instructions	7
Liability	7
Storage	7
4. Mounting / Installation	8
Scope of Supply	8
Mounting	8
Mounting Bolts	8
Operation Limits	8
Pressure Fluids	8
Electrical Connection	9
Electrical Interfacing	10
5. Operation Instructions	12
Solenoid Current Monitoring	12
ProPxD Parameterizing Software	12
Air Bleeding of Hydraulic System	13
Filter	13
Flushing	13
6. Trouble Shooting	13
7. Accessories / Spare Parts	14
Accessories	14
Spare Parts	14

Operation Manual

1. Introduction

Parker TPQ 3-way high-response valves have an integral electronic and requires only one sole electrical common for the control system. Different flow sizes are available to achieve an optimal adaption for different applications.

- high dynamic actuator principle with special designed electronic driver
- closed loop controlled spool position
- constant current actuator control with overcurrent shutoff
- excellent properties for response sensitivity and temperature drift
- differential input stage with various command signal options
- diagnostic output for spool stroke
- standard central connection
- compatible to the relevant European EMC-standards

Characteristics of Valve Driver

The described integral electronic driver combines all necessary functions for the optimal operation of the valve. Thanks to its excellent dynamic the valve is usable within closed loop control applications. The most important features are:



Ordering Code

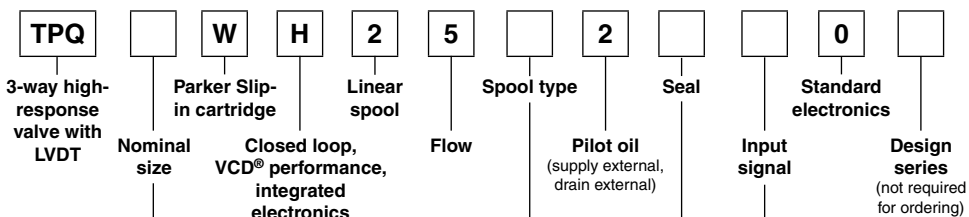

Code	Nominal size
025	NG25
032	NG32
040	NG40
050	NG50
063	NG63
080	NG80

Code	Signal range
B	0...±10 V
E	0...±20 mA
S	4...+20 mA

Code	Seal
N	NBR
V	FPM
H	for HFC fluids

Position overlap		
Code	Spool type	Fail save
	Input signal - 0 +	
P		P → A
T		A → T

Please order connector separately

Angle female connector must be used for NG25 to NG50.

TPQ_30 5715-653 UK 24.11.15



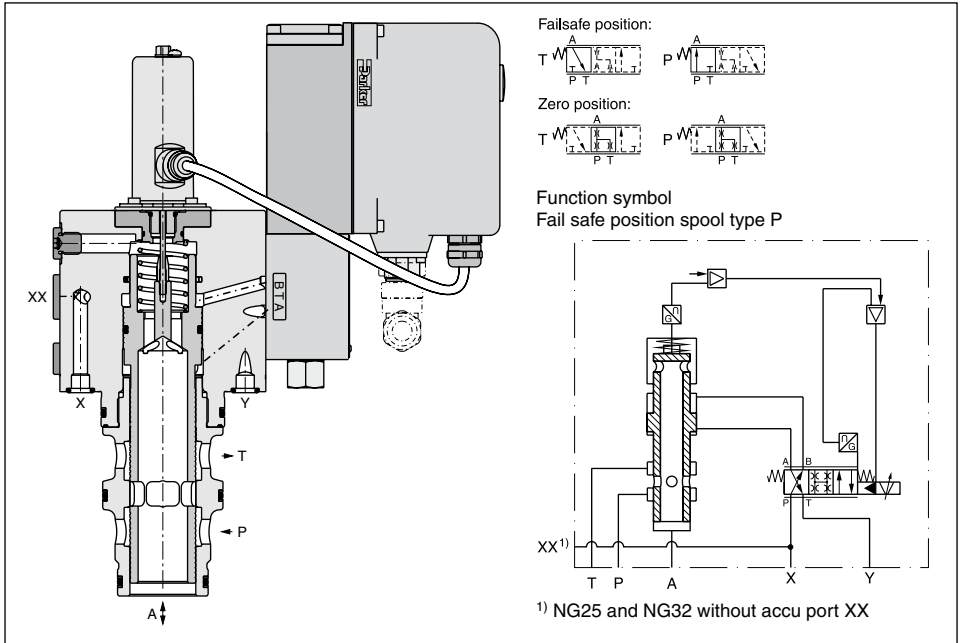

Blockdiagram of integrated electronics

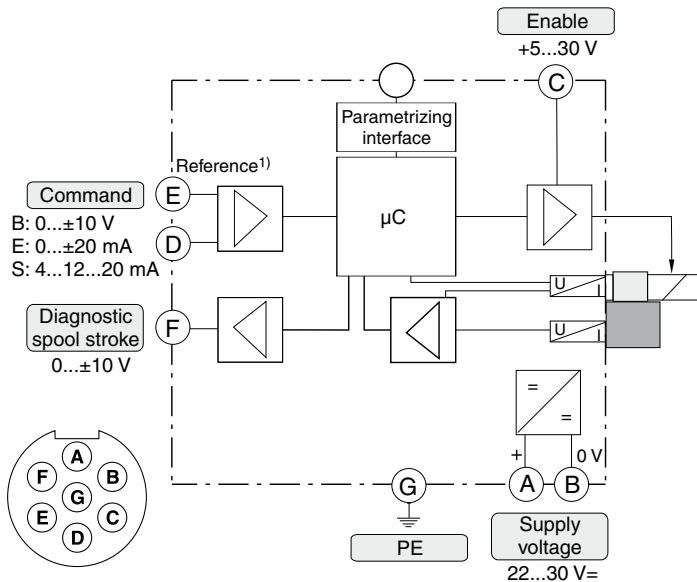

¹⁾ Do not connect with the supply voltage zero.

3-Way high-response valve Series TPQ

Operation Manual

Technical data

General							
Design	Proportional throttle valve, slip-in cartridge						
Nominal size	DIN	NG25	NG32	NG40	NG50	NG63	NG80
Mounting position	unrestricted						
Ambient temperature	[°C]	-20...+50					
MTTF _D value ¹⁾	[years]	75					
Weight	[kg]	11	13	15	26	52	105
Vibration resistance	[g]	10 sinus 5...2000 Hz acc. IEC 68-2-6 30 random noise 20...2000 Hz acc. IEC 68-2-36 15 shock acc. IEC 68-2-27					
Hydraulic							
Max. operating pressure	[bar]	Ports A, P, T, X up to 350, XX ²⁾ observe permissible pressure rating; port Y: max. 35					
Fluid	Hydraulic oil according to DIN 51524						
Fluid temperature	[°C]	-20 ... +60 (NBR -25...+60)					
Viscosity recommended	[cSt/	30 ... 80					
permitted	[mm ² /s]	20 ... 400					
Filtration	ISO 4406 (1999); 18/16/13						
Nominal flow at Δp = 5 bar	[l/min]	200	320	550	800	1450	2700
Recommended max. flow	[l/min]	500	1000	1600	2250	3500	6500
Nominal overlap	[%]	< 1.5					
Flow direction	A to T or P to A						
Pilot pressure	[bar]	must be as high as system pressure					
Pilot oil	supply drain	external via X external via Y					
Leakage in pilot valve at 100 bar	[ml/min]	< 400					
Leakage in main stage at 100 bar	[l/min]	NG32 to 63 <2.5; NG80 <4.0					
Pilot valve size			NG06			NG10	
Max. pilot flow at 140 bar pilot press.	[l/min]	25	25	25	25	50	60
Static/dynamic							
Step response at pilot press. >140 bar	[ms]	7	11	11	18	19	20
Frequency response at pilot press. >140 bar							
Amplitude -3 dB; ±5 %	[Hz]	210	105	70	45	35	30
Phase -90°; ±5 %	[Hz]	170	125	110	95	75	70
Hysteresis	[%]	< 0.1					
Sensitivity	[%]	< 0.05					
Temperature drift of center position	[%/K]	< 0.025					
Electrical							
Duty ratio	[%]	100					
Protection class	IP65 in accordance with EN 60529 (with correctly mounted plug-in connector)						
Supply voltage / ripple	[V]	DC 22 ... 30, electric shut-off at < 19, ripple < 5 % eff., surge free					
Current consumption max.	[A]	3.5					
Pre-fusing	[A]	4.0 A medium lag					
Input signal	Code B	Voltage	[V]	+10...0...-10, ripple < 0.01 % eff., surge free			
		Impedance	[kOhm]	100			
	Code E	Current	[mA]	+20...0...-20, ripple <0.01 % eff., surge free			
		Impedance	[Ohm]	<250			
	Code S	Current	[mA]	4...12...20, ripple <0.01 % eff., surge free			
		Impedance	[Ohm]	<250			
Differential input max.	[V]	30 for terminal D and E against PE (terminal G), 11 for terminal D and E against 0V (terminal B)					
Diagnostic signal	[V]	0...±10 rated max. 5 mA					
Enable signal	[V]	+10...0...-10 / +12.5 error detection, rated max. 5 mA					
EMC	EN 61000-6-2, EN 61000-6-4						
Electrical connection	6 + PE acc. EN 175201-804						
Wiring min.	[mm ²]	7x1.0 (AWG16) overall braid shield					
Wiring length	[m]	50					

¹⁾ If valves with onboard electronics are used in safety-related parts of control systems, in case the safety function is requested, the valve electronics voltage supply is to be switched off by a suitable switching element with sufficient reliability.

²⁾ Accu port XX: Please contact Parker for installation recommendation.

2. Safety Instructions

Please read the operation manual before installation, startup, service, repair or stocking! Paying no attention may result in damaging the valve or incorporated system parts.

Symbols

This manual uses symbols which have to be followed accordingly:



Instructions with regard to the warranty



Instructions with regard to possible damaging of the valve or linked system components



Helpful additional instructions

Work at the Valve

Workings in the area of installation, commissioning, maintenance and repair of the valve may only be allowed by qualified personnel. This means persons which have, because of education, experience and instruction, sufficient knowledge on relevant directives and approved technical rules.

3. Important Details

Intended Usage

This operation manual is valid for 3-way high-response valves TPQ series. Any different or beyond it usage is deemed to be as not intended. The manufacturer is not liable for warranty claims resulting from this.

Common Instructions

We reserve the right for technical modifications of the described product. Illustrations and drawings within this manual are simplified representations.

Due to further development, improvement and modification of the product the illustrations might not match precisely with the described valve. The technical specifications and dimensions are not binding. No claim may result out of it. Copyrights are reserved.

Liability

The manufacturer does not assume liability for damage due to the following failures:

- incorrect mounting / installation
- improper handling
- lack of maintenance
- operation outside the specifications



Do not disassemble the valve! In case of suspicion for a defect please contact Parker.

Storage

In case of temporary storage the valve must be protected against contamination, atmospheric exposure and mechanical damages. Each valve has been factory tested with hydraulic oil, resulting in protection of the core parts against corrosion. Yet this protection is only ensured under the following conditions:

Storage period	Storage requirements
12 months	constant humidity < 60 % as well as constant temperature < 25 °C
6 months	varying humidity as well as varying temperature < 35 °C



Outdoor storage or within sea and tropical climate will lead to corrosion and might disable the valve!

4. Mounting / Installation

Scope of Supply

Please check immediately after receiving the valve, if the content is matching with the specified scope of supply. The delivery includes:

- valve
- operation manual

The central connector has to be ordered separately and is not included in the delivery.

 Please check the delivery immediately after receiving the shipment for apparent damages due to shipping. Report shipment losses at once to the carrier and the supplier!

Mounting

- Compare valve type (located on the name plate) with part list resp. circuit diagram.
- The valve may be mounted fix or movable in any direction.
- Verify the mounting surface for the valve. Unevenness of 0.01 mm/100 mm, surface finish of 6.3 µm are tolerable values.

 Keep valve mounting surface and work environment clean!

- Remove protection plate from the valve mounting surface
- Check the proper position of the valve ports and the O-rings.
- Mounting bolts: use property class 12.9, ISO 4762



Insufficient condition of the valve mounting surface might create malfunction! Incorrect mounting resp. bolt torque may result in abrupt leakage of hydraulic fluid on the valve ports.



Y-port has always to be tied directly and separately to tank!

Limits of Use

The valve may be operated within the determined limits only. Please refer to the "technical data" section as well as to the "characteristic curves" in the Parker catalogue HY11-3500/UK "Hydraulic Valves Industrial Standard".



Follow the environmental conditions! Unallowable temperatures, shock load, aggressive chemicals exposure, radiation exposure, illegal electromagnetic emissions may result in operating trouble and may lead to failure! Follow the operating limits listed in the "specifications" table!

Available Bolt Kits

Size	Ordering no.	Dimensions	Torque
TPQ025	BK504	4 pcs. M12x100	108 Nm
TPQ032	BK529	4 pcs. M16x100	264 Nm
TPQ040	BK481	4 pcs. M20x110	517 Nm
TPQ050	BK481	4 pcs. M20x110	517 Nm
TPQ063	BK518	4 pcs. M30x160	1775 Nm
TPQ080	BK530	8 pcs. M24x160	517 Nm

Pressure Fluids

The following rules applies for the operation with various pressure fluids:



This information serves for orientation and does not substitute user tests among the particular operating conditions. Particularly no liability for media compatibility may be derived out of it.

HFA	Oil-in-water emulsion
HFB	Water-in-oil emulsion
HFD	Unhydryous fluids (Phosphor-Ester)



For detailed information concerning pressure fluids note VDMA-document 24317 as well as DIN 51524 & 51502.

Mineral oil: usable without restriction.

HFC: choose the right seal option.

For operation with the following pressure fluids please consult Parker:

Special gaskets may be available depending on the utilized fluid.

In case of doubt please consult Parker.

Electrical Connection

The electrical connection of the valve takes place by one common cable, which is coupled to the integrated electronic driver by a central connector assembly.

The connection requires a 6 + PE female connector EN 175201-804.

Female connector (ordering no. 5004072)
For NG63 and NG80

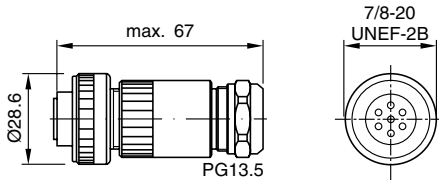

Angled female connector (ordering no. 5005160)
For NG25 to NG50

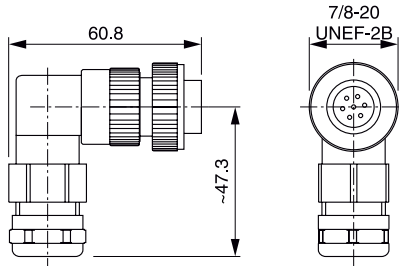

The connecting cable has to comply to the following specification:

Cable type	control cable, flexible, 7 conductors, overall braid shield
Cross section	min. AWG16
Outer dimension	8...12 mm
Cable length	max. 50 m

☞ For cable lengths > 50 m consult factory.

The connection cable is coupled to the female connector by solder joints.

Stripping lengths for the connecting cable:

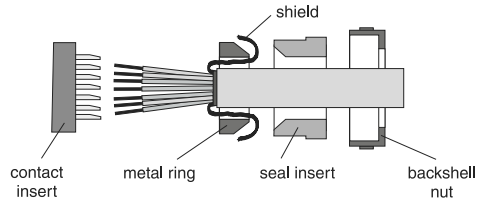
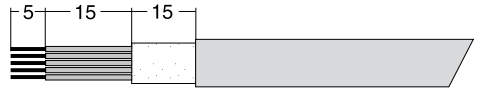

⚠ A female connector with metal housing is required! Plastic made models may create function problems due to insufficient EMC-characteristics.

⚠ Do not disconnect cable socket under tension!

The backshell nut of the cable gland has to be tightened with a suitable tool. The target value for the tightening torque is 4 Nm. Tighten the cap nut with a torque of 5 Nm after attaching the female connector on the socket.

⚠ Incomplete tightening of backshell nut respectively cap nut may result in undesired release of the connection as well as degradation of the water tightness.

When using female connectors of other manufacturers, the relevant regulations must be observed.

⚠ The cable may only be connected to the female connector by authorized and qualified personnel. A short between individual conductors resp. to the connector housing, bad soldering as well as improper shield connection may result in malfunction and breakdown of the valve.

⚠ The mounting surface of the valve has to be connected to the earth grounded machine frame. The earth ground wire from the valve connecting cable as well as the cable shield have to be tied to the protective earth terminal within the control unit. It is necessary to use a low ohmic potential connection between control unit and machine frame to prevent earth loops (cross section AWG 6).

Electrical Interfacing

Supply Voltage

The supply voltage for the valve has to cover the range of 22...30 V. Valve is de-energized below 19 V. The residual ripple may not exceed 5 % eff.

⚠ The applied power supply must comply to the relevant regulations (DIN EN 61558) and must carry a CE-mark. The operating voltage for the valve must be free of inductive surges. Do not exceed the max. value of 30 V! Higher voltage can lead to failure of the valve.

⚠ The increased inrush current of the valve should be considered when selecting the power supply. A stabilized power supply with overcurrent limiting feature should not be used. Due to the inrush current of the valve the current limit circuit may respond prematurely and create problems during energizing of the supply voltage.

⚠ The operation of the valve is blocked if the supply voltage polarity is interchanged.

⚠ Each valve requires a separate pre-fuse of 4 Amp semi time-lag. Failure to observe this instruction may create irreparable damage of valve respectively incorporated system parts.

Wiring diagram of supply voltage

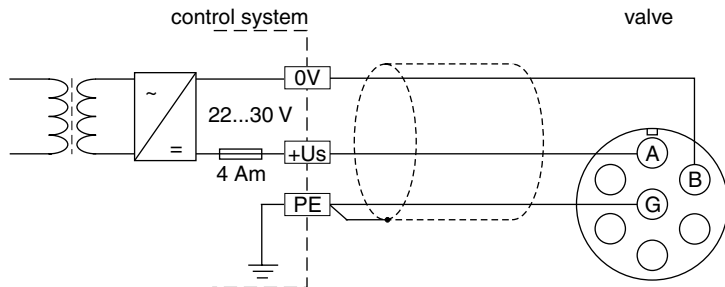

Enable input

A signal voltage enables the actuator drive of the valve. Continuous operation of the valve requires a permanent voltage 5...30 V (i.e. the supply voltage). In case of disabling the signal the valve will reach its power down position spring-actuated independently from the command signal value.



The enable function represents no safety arrangement against unwanted valve operation in terms of rules for accident prevention!

Command signal input

The spool stroke behaves proportional to the command signal amplitude.



The command input signal needs to be filtered as well as free of inductive surges and modulations. Due to the sensitivity of the valve a high signal quality is recommended, this will prevent malfunction.



The option 4...20 mA uses the “3.6 mA” condition as breakdown-information. If the input signal line is interrupted, an evaluable failure information is available. In this case the actuator drive will be switched off. The drive will switch on when the input signal reaches a value of 3.8 mA, it switches off when the command falls below 3.6 mA. This determination follows the NAMUR-specification NE43.

Diagnostics output

A diagnostics signal is available. Its voltage represents the operating condition of the valve.



The output may drive a load of max. 5 mA. Exceeding of this limit leads to malfunction.

Valves NG25 to NG50

Code command signal	Command signal	VCD actuator	Diagnostic signal
B	0...+10 V	on	0...+10 V
	0...-10 V	on	0...-10 V
	Overload	off	12.5 V
E	0...+20 mA	on	0...+10 V
	0...-20 mA	on	0...-10 V
	Overload	off	12.5 V
K	0...+10 V	on	0...-10 V
	0...-10 V	on	0...+10 V
	Overload	off	12.5 V
S	4...12 mA	on	0...-10 V
	12...20 mA	on	0...+10 V
	0...3.6 mA	off	Cable break, 12.5 V
	Overload	off	12.5 V

Valves NG63 and NG80

Code command signal	Command signal	VCD actuator	Diagnostic signal
B	0...+10 V	on	0...-10 V
	0...-10 V	on	0...+10 V
	Overload	off	12.5 V
E	0...+20 mA	on	0...-10 V
	0...-20 mA	on	0...+10 V
	Overload	off	12.5 V
K	0...+10 V	on	0...+10 V
	0...-10 V	on	0...-10 V
	Overload	off	12.5 V
S	4...12 mA	on	0...+10 V
	12...20 mA	on	0...-10 V
	0...3.6 mA	off	Cable break, 12.5 V
	Overload	off	12.5 V

5. Operating Instructions

 Supply pressure must be ensured before valve is energized.

Solenoid Current Monitoring

If the actuator current time interval exceeds 10 seconds, the actuator is switched off to prevent overheating. For normal operating conditions this state will not be reached, but it may occur with a contaminated sluggish valve.

 In this case the reason for the contamination should be repaired (hydraulic fluid exchange, filtration review, valve flushing).

The overcurrent shutoff condition may be reset by temporary disconnection of the enable signal.

 The shutoff of the VCD actuator due to overload will be indicated via the diagnostics output.

ProPxD parameterizing software

The ProPxD software permits comfortable parameter setting for the module electronic. Via the clearly arranged entry mask the parameters can be noticed and modified. Storage of complete parameter sets is possible as well as printout or record as a text file for further documentation.

The PC software can be downloaded free of charge at www.parker.com/euro_hcd - see page "Support" or directly at www.parker.com/propxd.

Please check periodically for updates.

Hardware requirements

- PC with operating system from Windows® XP upwards
- interface RS232C
- display resolution min. 800 x 600
- connection cable between PC and electronic module
- storage requirement approx. 40 MB

 If your PC has no serial interface according to RS232 standard you require in addition a USB-RS232C adapter.

Cable Specification

 Attention! The valve electronic provides no USB interface, but can only be parameterized via an RS232C connection. Therefore the usage of USB standard cables is not allowed and may result in damaging of valve resp. PC.

Parametrizing

Ordering code: 40982923

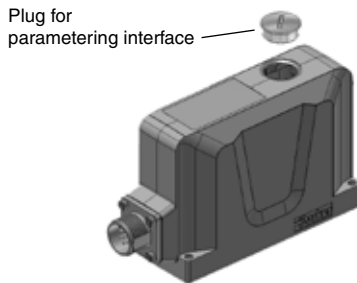
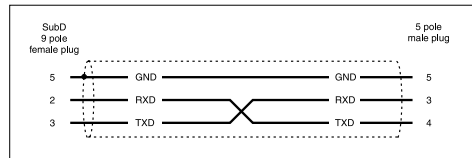
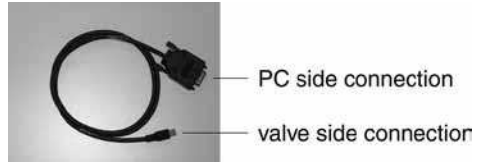

 The cover plug has to be re-installed after completion of the parametrizing work.

Air Bleeding of Hydraulic System

During initial startup, after an oil change as well as after the opening of lines or valves the hydraulic system must be air bled.

Filter

The function and lifetime of the valve are strongly affected by the cleanliness of the fluid.

Purity level class of 18/16/13 acc. ISO4406 is required.

Flushing

It is recommended to flush the pipelines by short circuiting the pressure and return lines. This prevents the installation dirt from entering the valve.

6. Troubleshooting

Basis of troubleshooting is always a systematic approach.



For suspect of a sluggish spool the valve may be flushed with clean pressure fluid.



Troubleshooting in a hydraulic system requires detailed knowledge about function and construction of the system. Therefore the work may exclusively be performed by qualified personnel.

malfunction at hydraulic load runtime						
- generally no function						
- high frequent oscillation						
- low frequent oscillation						
- speed variations at unchanging command						
- different speeds depending on travel direction						
- speed too low						
- drifting without command						
possible reasons for malfunction			corrective actions			
X					hydraulic pump resp. motor defective	replace hydraulic pump resp. motor
X	X	X	X	X	drive overloaded	reduce pressure resp. speed, increase valve size
X	X	X	X	X	valve contaminated	clean pressure fluid, filter / flush valve
		X		X	hydraulic fluid too viscous / too cold	change fluid grade, provide operational temperature
X	X				too low oil level within tank	refill pressure fluid
		X	X	X	filter contaminated	clean resp. replace filter
X	X			X	supply voltage too low	keep supply voltage range
	X				supply voltage carries too much ripple	reduce ripple
X				X	command signal too low	increase command signal
	X				command signal carries too much ripple	reduce ripple
			X		center position adjustment incorrect	check center position adjustment
X	X	X	X	X	contacts of central connector contaminated	clean contacts / replace plug
X					feed cable interrupted	fix feed cable
X	X	X	X	X	wiring sequence incorrect	correct wiring sequence
X	X			X	feed cable without shielding	change cable grade

7. Accessories

The following accessories are available for the valve series TPQ*H:

female connector 6+PE ordering code 5004072

Mounting bolts see table on page 8.

Spare parts / seal kits

Size	NBR	FPM
TPQ025	SK-TPQ025EN30	SK-TPQ025EV30
TPQ032	SK-TPQ025EN30	SK-TPQ032EV30
TPQ040	SK-TPQ040EN30	SK-TPQ040EV30
TPQ050	SK-TPQ050EN30	SK-TPQ050EV30
TPQ063	SK-TPQ063EN30	SK-TPQ063EV30
TPQ080	SK-TPQ080EN30	SK-TPQ080EV30

Please direct technical product enquiries to:

**Parker Hannifin
Manufacturing Germany GmbH & Co. KG**

Hydraulic Controls Division Europe

Gutenbergstr. 38

41564 Kaarst, Germany

Tel.: (+49) 181 99 44 43 0

E-mail: valveshcd@parker.com

<p>Hotline in Europe Tel.: 00800-2727-5374</p>
--