

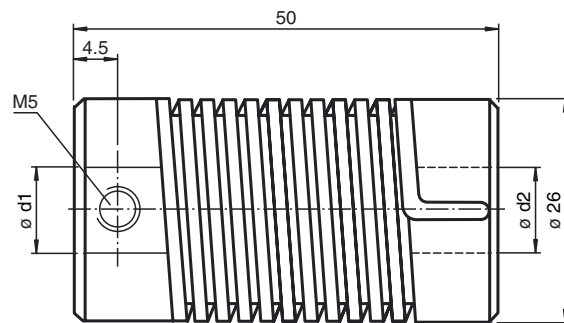

## Dimensions



### Model Number

**9401 10\*12**

Spring steel coupling

### Features

- Universally suitable for backlash-free rotation transmission
- Highly vibration-isolating
- Well misalignment compensation
- Low torsion spring stiffness
- Small reset forces
- No movable parts
- Very rugged construction

## Technical data

### Ambient conditions

Operating temperature -30 ... 120 °C (-22 ... 248 °F)

### Mechanical specifications

Shaft diameter  $d1 = 10 \text{ mm}$ ,  $d2 = 12 \text{ mm}$

Material

Spring spring steel, nickel plated

End piece Diecast zinc

Mass 100 g

Rotational speed max. 3000 min

Max. torque 1.5 Nm

Tightening torque, fastening screws 1.2 Nm

Radial offset max.  $\pm 1.5 \text{ mm}$

Axial offset max.  $\pm 1 \text{ mm}$

Angle error max.  $\pm 5^\circ$

Torsion angle at torque 0.75 Nm drive shaft view

CW rotation direction  $40^\circ$

CCW rotation direction  $60^\circ$

Moment of inertia  $95 \text{ kg m}^2 \times 10^{-7}$

Mounting clamp screws M5 x 6, DIN 916

Tightening torque of clamping screws max. 3 Nm