



### Model Number

**IVH-F61**

System IV read/write head

### Features

- Particularly flat construction
- 2 m connection cable
- Can be mounted on metal
- Degree of protection IP67

### Dimensions

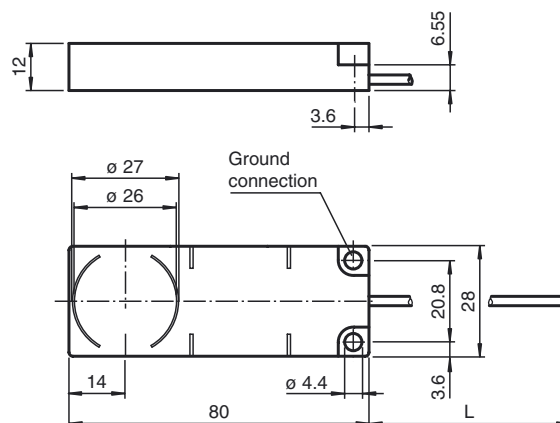

### Electrical connection

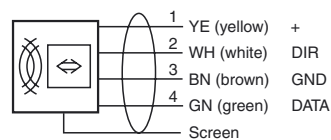

### Technical data

#### General specifications

Operating frequency	250 kHz
Transfer rate	7.8 kBit/s
Operating distance	maximum: 66 mm

#### Electrical specifications

Power consumption	$P_0$	1.1 W
-------------------	-------	-------

#### Ambient conditions

Ambient temperature	-25 ... 70 °C (-13 ... 158 °F)
Storage temperature	-40 ... 85 °C (-40 ... 185 °F)

#### Mechanical specifications

Degree of protection	IP67 according to EN 60529
Connection	2 m PUR cable
Material	
Housing	PBT
Encapsulation compound	CY 221/HY 2966
Installation	
Distance between two heads	≥ 300 mm