

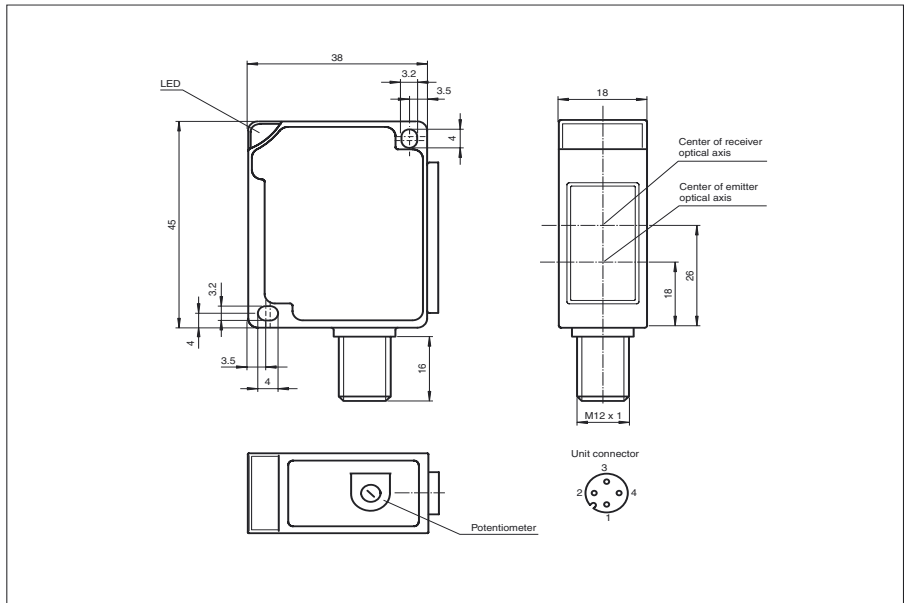

Dimensions



Model Number

MLV13-54/32/40b/73c

with 4-pin, M12 connector

Features

- Visible red light
- Glare protected with polarisation filter
- Pre-fault indication
- Control input for light-/dark switching
- Protection degree IP67

Electrical connection

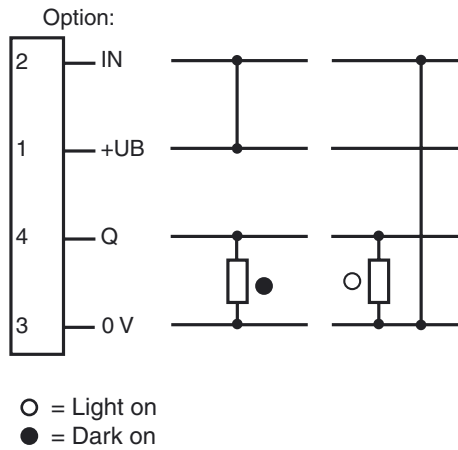

Release date: 2007-08-15 16:21 Date of issue: 2007-08-15 088776_ENG.xml

Technical data**General specifications**

Effective detection range	0 ... 6 m
Threshold detection range	7 m
Light source	LED
Approvals	CE
Reference target	reflector C110-2
Light type	red, modulated light
Diameter of the light spot	200 mm at a distance of 6000 mm
Ambient light limit	10000 Lux

Indicators/operating means

Function display	switching state: LED yellow pre-fault indicator: LED red
Operating elements	sensitivity adjuster

Electrical specifications

Operating voltage	10 ... 30 V DC
Ripple	10 %
No-load supply current	$I_0 \leq 25 \text{ mA}$
Time delay before availability	$t_v \leq 80 \text{ ms}$

Input

Control input	Light ON: +UB Dark ON: 0 V
---------------	-------------------------------

Output

Switching type	light/dark switching
Signal output	1 PNP output, short-circuit proof, protected from reverse polarity, open collector
Switching voltage	max. 30 V DC
Switching current	max. 200 mA
Voltage drop	$U_d \leq 2.5 \text{ V DC}$
Switching frequency	$f \leq 500 \text{ Hz}$
Response time	$\leq 1 \text{ ms}$

Standard conformity

Standards	EN 60947-5-2
-----------	--------------

Ambient conditions

Ambient temperature	-25 ... 70 °C (248 ... 343 K)
Storage temperature	-40 ... 70 °C (233 ... 343 K)

Mechanical specifications

Protection degree	IP67
Connection	M12 connector, 4-pin
Material	
Housing	ABS
Optical face	scratch resistant plastic pane
Mass	40 g

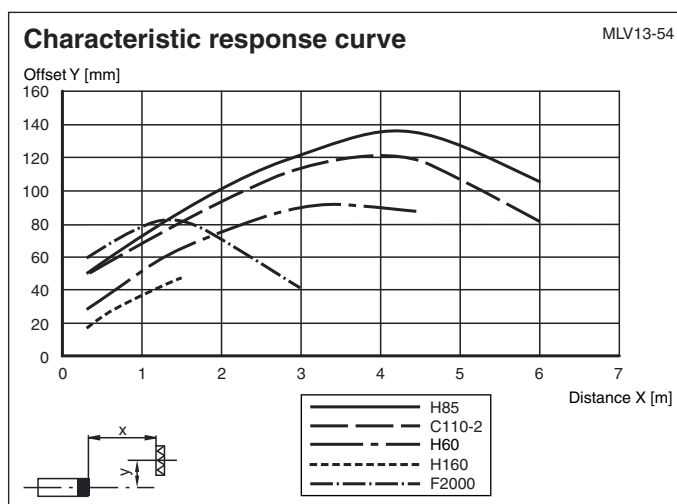
Curves/Diagrams

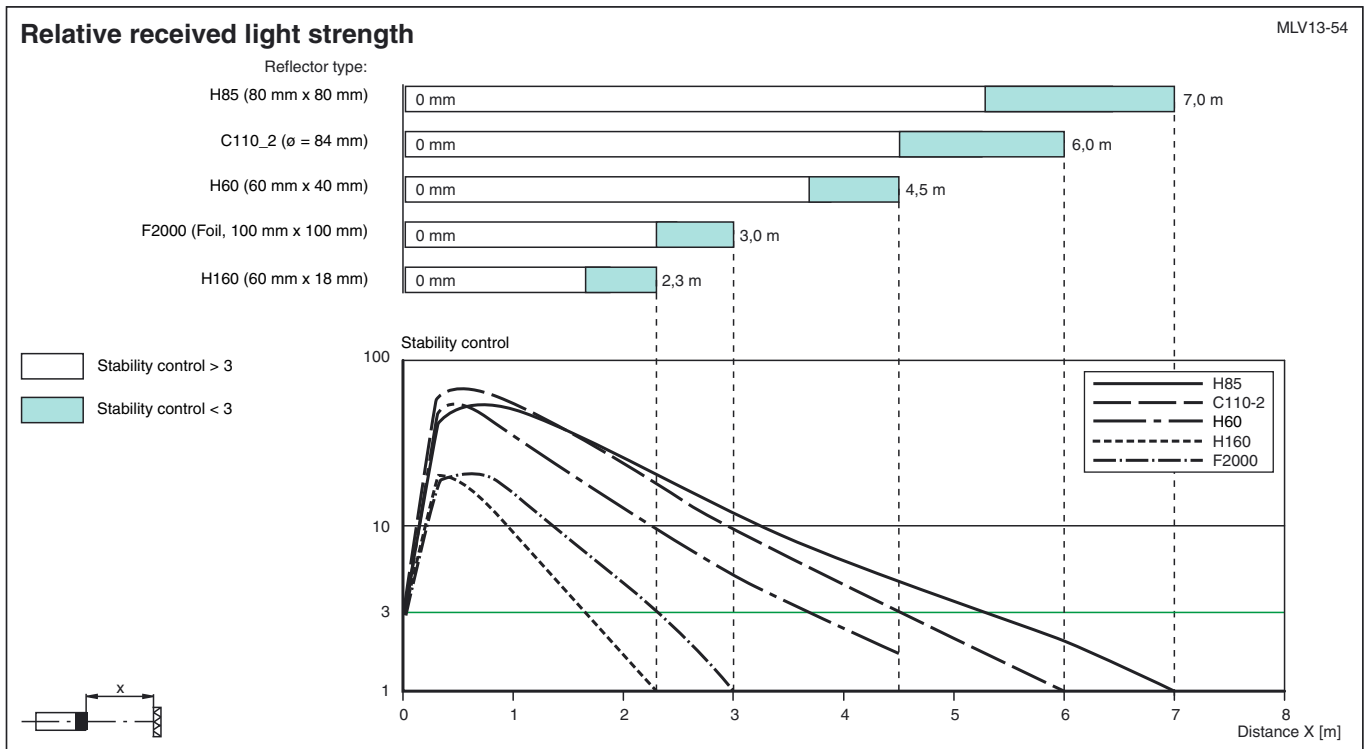

Additional Information

Conventional use:

The reflex light beam switch contains the emitter and receiver in a single housing. The light from transmitter is beamed back from a reflector to the receiver. If an object interrupts the light beam the switching function is initiated.

Mounting instructions:

The sensor can be fastened over the through-holes directly or with the included mounting bracket.

The base surface must be flat to avoid distorting the housing during mounting. It is advisable to secure the bolts and screws with washers to prevent misalignment of the sensor.

Instructions for adjustment:

Connect the sensor to operating voltage, the LED green lights up constantly.

Mount suitable reflector opposite light beam switch and align roughly.

The exact adjustment takes by swivelling the sensor horizontally and vertically. With optimum light reception the yellow LED lights up constantly. In case of bad alignment, the red LED lights up.

Object detection check:

Move the object into the light beam. If the object is recorded, the yellow LED goes off. If it isn't going off, reduce the sensitivity with the potentiometer until it goes off. It should light up constantly again when the object is removed.

The red LED lights up if reception deteriorates (e.g. soiled lenses or by maladjustment) and when falling short of the stability control.

Illustration:

We recommend that you clean the optical interfaces and check the plug-in connections and screw connections at regular intervals.