

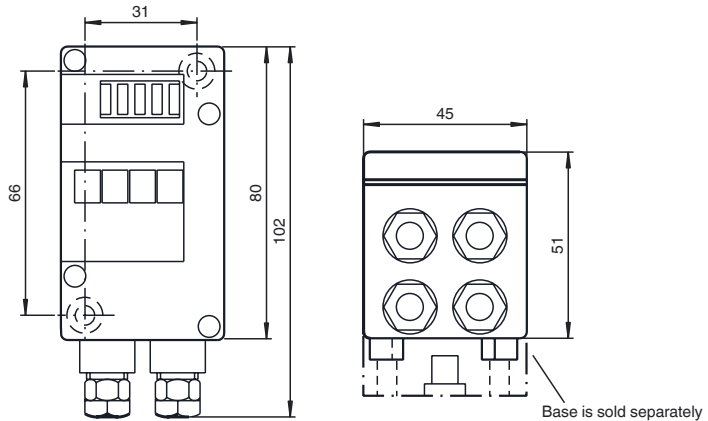

**Dimensions**

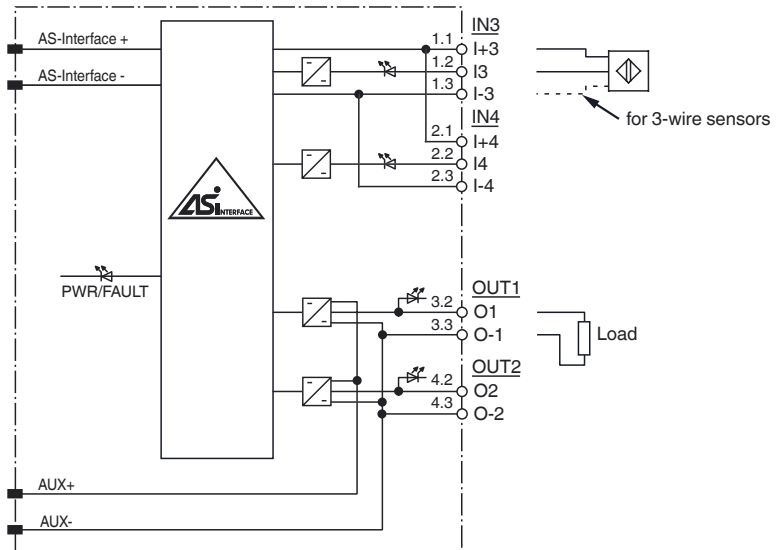

**Electrical connection**



**Model number**

**VBA-2E2A-G4-ZE/E2**

G4 module IP67  
2 inputs (PNP) and 2 electronic outputs

**Features**

- Protection degree IP67
- A/B slave with extended addressing possibility for up to 62 slaves
- Flat or round cable connection (via standardized EEMS base, not included with delivery)
- Cable piercing method for flat cable
- Communication monitoring
- Inputs for 2- and 3-wire sensors
- Power supply of outputs from the external auxiliary voltage
- Supply for inputs from AS-Interface
- Function display for bus, inputs and outputs
- LED indicator for overload on sensor supply
- Detection of output overload

**Indicating / Operating means**

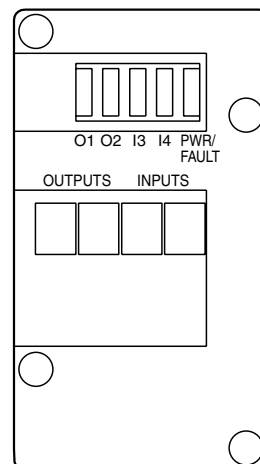

Release date: 2011-07-13 15:13 Date of issue: 2014-01-13 088914\_eng.xml

**Technical data****General specifications**

Slave type	A/B slave
AS-Interface specification	V2.1
Required master specification	≥ V2.1
UL File Number	E87056

**Indicators/operating means**

LED PWR/FAULT	dual LED green/red green: AS-Interface voltage red: communication error or address 0 green/red flashing: overload sensor supply or outputs
LED IN	switching state (input); 2 LED yellow
LED OUT	Switching state (output); 2 LED yellow

**Electrical specifications**

Auxiliary voltage (output)	$U_{AUX}$	24 V DC ± 15 % PELV
Rated operating voltage	$U_e$	26.5 ... 31.6 V from AS-Interface
Rated operating current	$I_e$	≤ 30 mA (without sensors) / max. 140 mA
Protection class		III

**Input**

Number/Type	2 inputs for 2- or 3-wire sensors (PNP), DC
Supply	from AS-Interface
Voltage	21 ... 31 V
Current loading capacity	≤ 100 mA ( $T_B \leq 40 \text{ °C}$ ), ≤ 75 mA ( $T_B \leq 60 \text{ °C}$ ), overload-proof and short-circuit protected
Input current	≤ 8 mA (limited internally)
Switching point	according to DIN EN 61131-2 (Type 2)
0 (unattenuated)	≤ 2 mA
1 (attenuated)	≥ 4 mA

**Output**

Number/Type	2 electronic outputs, PNP overload and short-circuit proof
Supply	from external auxiliary voltage $U_{AUX}$
Current	1 A per output
Voltage	≥ ( $U_{AUX} - 0.5 \text{ V}$ )

**Programming instructions**

Profile	S-B.A.0
IO code	B
ID code	A
ID1 code	7
ID2 code	0

Data bits (function via AS-Interface)	input	output
D0	-	OUT1
D1	-	OUT2
D2	IN3	-
D3	IN4	-

Parameter bits (programmable via AS-i)	function
P0	not used
P1	not used
P2	not used
P3	not used

**Ambient conditions**

Ambient temperature	-25 ... 60 °C (-13 ... 140 °F)
Storage temperature	-25 ... 85 °C (-13 ... 185 °F)

**Mechanical specifications**

Protection degree	IP67
Connection	cable piercing method or terminal compartment yellow flat cable/black flat cable or standard round cable inputs/outputs: M12 x 1.5 cable glands and cage tension spring terminals
Material	
Housing	PA 6 GF30
Mass	180 g
Mounting	DIN rail or screw mounting

**Compliance with standards and directives**

Directive conformity	
EMC Directive 2004/108/EC	EN 61000-6-2:2001, EN 61000-6-4:2001, EN 50295:1999
Standard conformity	
Noise immunity	EN 61000-6-2:2001
Emitted interference	EN 61000-6-4:2001
AS-Interface	EN 50295:1999
Input	EN 61131-2:2007
Protection degree	EN 60529:2000

**Function**

The VBA-2E2A-G4-ZE/E2 AS-Interface module is equipped with 2 inputs and 2 outputs. The inputs permit the connection of mechanical contacts and of 2- and 3-wire sensors. The sensors are supplied via the module. The outputs are electronic outputs, which can be loaded to 24 V DC and 1 A per output.

The IP67 rated G4 module is particularly suitable for rough conditions. Sensors and actuators attach to cable glands and cage tension spring terminals thus making the installation especially user-friendly. For pre-addressing the module it can be plugged directly onto the adapter of the hand-held programming device VBP-HH1.

The current switching state of each channel is indicated by an LED, located on the module's top side. In the case of communication errors on the bus, the outputs are de-energised via an integrated watchdog.

Both flat and round cables can be used for the connection of the AS-Interface transmission line and the external 24 V DC power supply. Use the U-G1FF base for the AS-Interface flat cable. The AS-Interface standardised EEMS interface, uses the cable piercing method to connect both the yellow and black flat cables.

Use the U-G1PP base for a round cable. The AS-Interface-cable as well as the external power supply may be connected within the U-G1PP base.

**Note:**

The device incorporates communication monitoring, which switches off power to the outputs if no communication has taken place on the AS-Interface line for longer than 40 ms.

An overloading of the internal input supply or of the outputs is signalled to the AS-Interface master via the "Peripheral fault" function. Communication via the AS-Interface remains intact.

**Accessories****VBP-HH1-V3.0-KIT**

AS-Interface Handheld with accessory

**VBP-HH1-V3.0**

AS-Interface Handheld

**VAZ-G4-B**

Blind plug PG7

**VAZ-G4-B1**

Blind plug M12

**Matching system components****U-G1FF**

AS-Interface module mounting base for connection to flat cable (AS-Interface and external auxiliary power)

**U-G1FFA**

AS-Interface module mounting base with addressing jack for connection to flat cable (AS-Interface and external auxiliary power)

**U-G1PP**

AS-Interface module mounting base for connection to round cable (AS-Interface and external auxiliary power)

**Notes**

Do not connect inputs and outputs, which are supplied via the module from AS-interface or via auxiliary power, with power supply and signal circuits with external potentials.