

CE

### Model Number

**RT1 X 100**

Reflective tape

### Features

- Reflective tape, pre-cut, corner-cube
- 150' rolls available
- Can be cut

### Dimensions

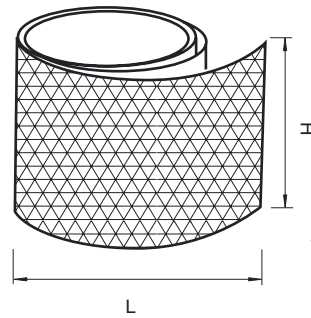

### Technical data

#### General specifications

Construction type rectangular

#### Ambient conditions

Ambient temperature -20 ... 82.22 °C (-4 ... 180 °F)

#### Mechanical specifications

Dimensions 1.0" x 100.0" (2.54 x 254 cm)

Mounting self-adhesive

Storage Store cool and dry

### Note

#### Reflectors

Polarized retro-reflective sensors must use corner-cube reflectors.

Microstructure, corner-cube reflectors are used with laser retro-reflective sensors that have short sensing distances.