

Features

- 1-channel signal conditioner
- 230 V AC supply
- Level sensing input
- Adjustable range 1 kΩ ... 30 kΩ
- Relay contact output
- Minimum/maximum control

Function

This signal conditioner provides the AC measuring voltage for the level-sensing electrodes.

Once the measured medium reaches the electrodes, the unit reacts by energizing a form C changeover relay contact.

The module is voltage and temperature stabilized and guarantees defined switching characteristics. An electronic holding circuit is used that allows minimum/maximum control. Since the conductance of the media may vary, the relay response sensitivity is adjustable.

The normal output state can be reversed through the mode of operation switch S1.

Assembly

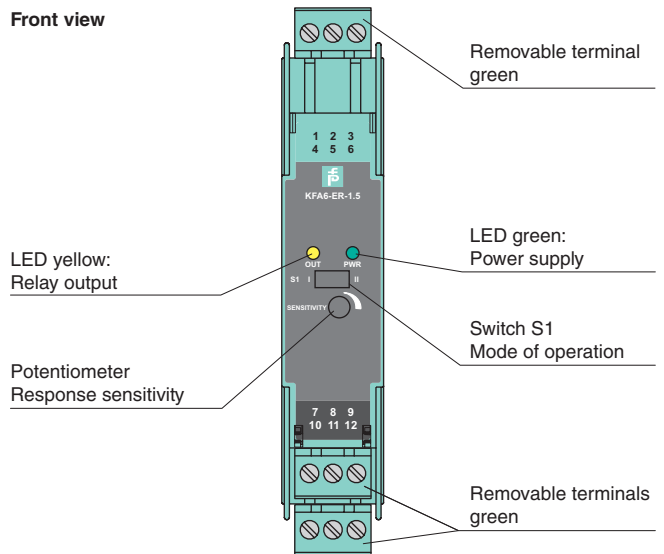

Connection

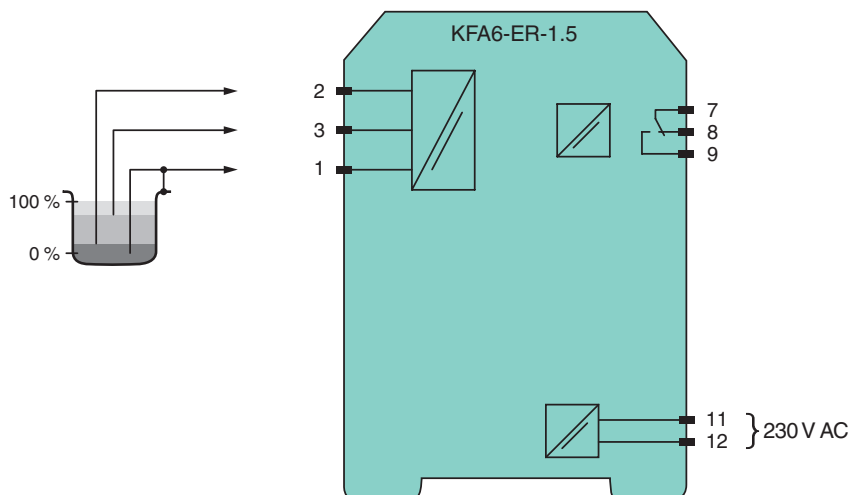

Release date 2012-09-26 14:52 Date of issue 2015-02-16 096045_eng.xml

Refer to "General Notes Relating to Pepperl+Fuchs Product Information".

General specifications	
Signal type	Digital Input
Supply	
Connection	terminals 11 (L1), 12 (N)
Rated voltage U_n	207 ... 253 V AC, 45 ... 65 Hz
Power consumption	approx. 0.8 W
Input	
Connection	terminals 1 (mass), 2 (min), 3 (max)
Open circuit voltage/short-circuit current	approx. 10 V AC (approx. 1 Hz) / approx. 5 mA
Control input	min./max. control system: terminals 1, 2, 3 on/off control system: terminals 1, 3
Response sensitivity	1 ... 30 k Ω , adjustable via potentiometer (20 turns)
Output	
Connection	terminals 7, 8, 9
Output	1 changeover contact
Contact loading	253 V AC/2 A/cos ϕ > 0.7; 40 V DC/2 A resistive load
Energized/De-energized delay	approx. 1 s / approx. 1 s
Electrical isolation	
Input/Output	basic insulation according to EN 50178, rated insulation voltage 253 V _{eff}
Input/power supply	basic insulation according to EN 50178, rated insulation voltage 253 V _{eff}
Output/power supply	basic insulation according to EN 50178, rated insulation voltage 253 V _{eff}
Directive conformity	
Electromagnetic compatibility	
Directive 2004/108/EC	EN 61326-1:2006
Low voltage	
Directive 2006/95/EC	EN 50178:1997
Conformity	
Insulation coordination	EN 50178:1997
Electrical isolation	EN 50178:1997
Electromagnetic compatibility	NE 21:2006
Degree of protection	IEC 60529:2001
Ambient conditions	
Ambient temperature	-20 ... 60 °C (-4 ... 140 °F)
Mechanical specifications	
Degree of protection	IP20
Connection	screw connection, max. 2.5 mm ²
Mass	approx. 110 g
Dimensions	20 x 107 x 115 mm (0.8 x 4.2 x 4.5 in), housing type B1
Mounting	on 35 mm DIN mounting rail acc. to EN 60715:2001
Indication and operation	
Control elements	switch S1 Position I open circuit current: In the open circuit current principle, the relay becomes active when the limit is reached. Position II closed circuit current: In closed circuit current principle, the relay is activated when power is applied. The relay is deactivated when the limit is reached.
General information	
Supplementary information	Statement of Conformity, Declaration of Conformity, Attestation of Conformity and instructions have to be observed where applicable. For information see www.pepperl-fuchs.com .

Release date 2012-09-26 14:52 Date of issue 2015-02-16 096045_eng.xml