



**Model number**

**VAA-4E2A-G5-N/V2-Ex**

G5 Ex module  
4 inputs/2 valve outputs

**Features**

- Use in hazardous area
- Category, ignition protection category  $\text{Ex II (1GD) 2G Ex e mb [ia] IIB/IIC T4}$
- Connection of 4 sensors based on IEC 60947-5-6 (NAMUR, DIN 19234)
- Optional standard connection or 2:1 system
- Connection of 2 switch valves
- Lead breakage and short-circuit monitoring for inputs
- Function display for bus, status display for inputs and outputs

**Dimensions**

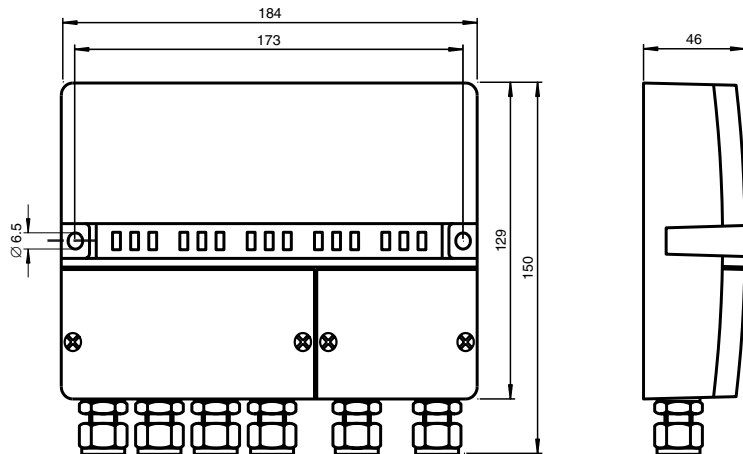

**Electrical connection**

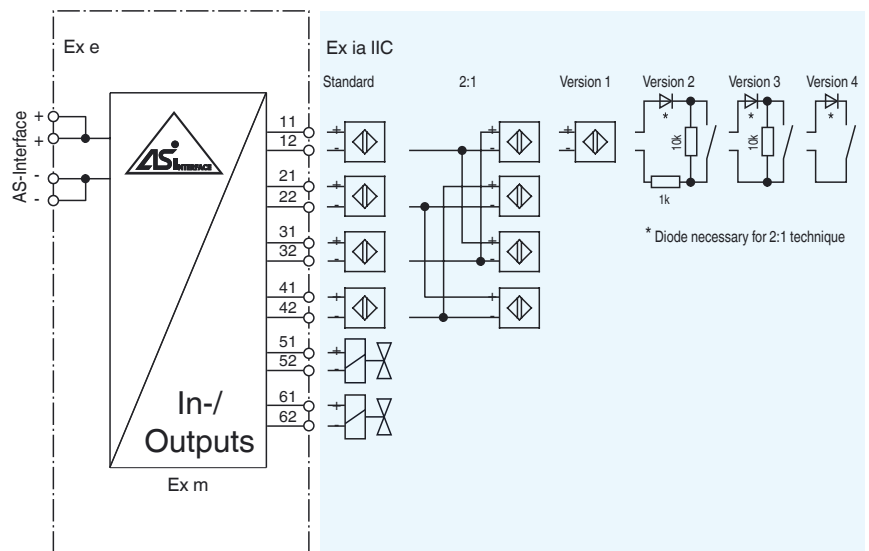

**Indicating / Operating means**



DIP-switch (in terminal compartment)

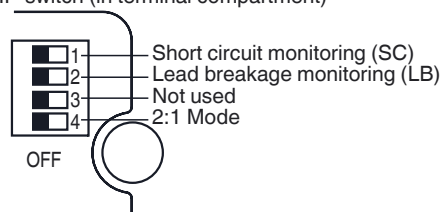

Release date: 2012-08-20 15:08 Date of issue: 2014-01-13 102352\_eng.xml

Refer to "General Notes Relating to Pepperl+Fuchs Product Information".

## Technical data

### General specifications

Slave type	Standard slave
EC-Type Examination Certificate	DMT 02 ATEX E 125
Group, category, type of protection	Ex II (1GD) 2G Ex e mb [ia] IIB/IIC T4 Intrinsically safe input and output circuits can be laid in the 1G and 1D category areas.

### Indicators/operating means

LED PWR/CHK	dual LED green/red green: AS-Interface voltage red flashing: communication error or address 0 or SC/LK error
LED IN	4 dual LED yellow/red yellow: switching state (input) red flashing: SC/LK error
LED OUT	Switching state (output); 2 LED yellow

### Electrical specifications

Rated operating voltage	$U_e$	26.5 ... 31.6 V PELV from AS-Interface
Rated operating current	$I_e$	≤ 90 mA
Maximum safe voltage	$U_m$	40 V
Short-circuit current	$I_k$	≤ 35 A

### Input

Number/Type	4 inputs according to IEC 60947-5-6 (NAMUR, DIN 19234)
Switching point	OFF ≤ 1.2 mA ON ≥ 2.1 mA

Values in accordance with EC-Type Examination Certificate: Extract; Other values for mixed and parallel circuits (2:1 mode): see EC-Type Examination Certificate

Voltage	$U_0$	≤ 8.8 V DC
Current	$I_0$	≤ 11.5 mA
Power	$P_0$	≤ 25.3 mW
Internal resistor	$R_i$	≥ 765 Ω
Internal capacitance	$C_i$	negligible
Internal inductance	$L_i$	negligible
Type of protection		Ex ia IIB                      Ex ia IIC
External capacitance	$C_0$	≤ 46 μF                      ≤ 5.5 μF
External inductance	$L_0$	≤ 1 H                            ≤ 0.6 H
L/R-ratio	$L_0/R_0$	≤ 5.6 mH/Ω                      ≤ 1.4 mH/Ω
Characteristic curve		linear

### Output

Number/Type	2 outputs for control of intrinsically safe valves
-------------	--

Values in accordance with EC-Type Examination Certificate

Voltage	$U_0$	≤ 28 V DC
Current	$I_0$	≤ 110 mA
Power	$P_0$	≤ 770 mW
Internal resistor	$R_i$	≥ 258 Ω
Type of protection		Ex ia IIB                      Ex ia IIC
External capacitance	$C_0$	≤ 650 nF                      ≤ 83 nF
External inductance	$L_0$	≤ 10 mH                        ≤ 1 mH
L/R-ratio	$L_0/R_0$	≤ 180 μH/Ω                      ≤ 46 μH/Ω
Characteristic curve		linear
Nominal values		(typically)
Open loop voltage	$U_{A0}$	26 V
Short-circuit current	$I_{AK}$	50 mA
Internal resistor	$R_i$	270 Ω
Curve angle points (nominal values)		12.5 V DC, 50 mA
$U_{E/I_E}$		

### Programming instructions

Profile	S-7.F
IO code	7
ID code	F

Data bits (function via AS-Interface)	input	output
D0	IN1	OUT1
D1	IN2	-
D2	IN3	OUT2
D3	IN4	-

### Parameter bits (programmable via AS-i) function

P0/P1	(Output conditions on failure of the AS-Interface communication or LB/LK error) 0/0 outputs unchanged 0/1 outputs not controllable 1/0 outputs controllable 1/1 outputs not controllable
P2	not used
P3	not used

### Ambient conditions

Ambient temperature	-20 ... 60 °C (-4 ... 140 °F)
Storage temperature	-20 ... 85 °C (-4 ... 185 °F)

## Function

The VAA-4E2A-G5-N/V2-Ex module is suitable for direct use in areas subject to the danger of explosion (Zone 1). The module itself is encapsulated (Ex m), while the connection technology for the AS-Interface-lead is designed for the increased safety category and the control circuits are designed to conform to Ex ia IIC.

The VAA-4E2A-G5-N/V2-Ex module makes it possible to operate 4 sensors in accordance with IEC 60947-5-6 (NAMUR) or mechanical contacts and 2 intrinsically safe valves. Four variations are possible for connecting the sensors/mech. contacts (see electrical connection):

**Variant 1:** Connection of NAMUR sensors, see connection assignment.

**Variant 2:** If the mechanical contacts are wired according to the connection diagram, monitoring for lead breakage and short-circuit is possible.

**Variant 3:** If the mechanical contacts are provided with only one 10 kΩ parallel resistor, the lead can be monitored for lead breakage. In this case, short-circuit monitoring must be turned off.

**Variant 4:** No type of monitoring at all is available for this variant. In this case, lead breakage monitoring and short-circuit monitoring must be turned off.

The DIP switches are located in the terminal compartment for sensor/valve connections (see the representation of the DIP switches).

### Lead breakage / short-circuit:

Error monitoring is activated when the current in the control circuit I is less than 0.1 mA (lead breakage) or greater than 6 mA (short circuit). In this case the LED of the input in question and the LED PWR/CHK both flash red, and the module logs out from the AS-Interface.

### Note:

If two channels are connected incorrectly, the output voltage may be reduced. To reset a module, it has to be disconnected from the supply.

### 2:1 Mode:

The 2:1 mode enables any two sensors to be connected via a common 2-wire cable. Since in this mode the selection of the individual sensors is made via the polarity of the sensor supply, reverse polarity-protected sensors must be used for this operating mode.

Sensors 1 and 3 form the first pair; sensors 2 and 4 the second. The sensors of a pair are connected anti-parallel to the module via a 2-wire cable. The first pair occupy terminals 12 and 32 (Sensor 1+ to terminal 32, Sensor 3+ to terminal 12). The second pair occupy terminals 22 and 42 (Sensor 2+ to terminal 42, Sensor 4+ to terminal 22).

For mechanical contacts a serial diode is required for reverse polarity protection for operation in the 2:1 mode. The connection is made in the same sense as for the sensors (Contact 1+ to terminal 32, Contact 3+ to terminal 12, etc.). The 2:1 mode is activated via DIP switch 4 in the terminal compartment for the inputs and outputs. To activate and deactivate the mode the supply voltage (AS-Interface) must be briefly isolated from the device.

## Accessories

**VAZ-RK-PUR 2x1,5-YE 100M**  
AS-Interface round cable

**Mechanical specifications**

Protection degree	IP54 according to EN 60529
Connection	screw terminals
Mass	1.5 kg
Mounting	screw mounting
Tightening torque	Terminal compartment cover = 1.5†Nm

**Notes****Valve coupler:**

The block diagram at right illustrates the combined effect of the module and a valve switch. The module, with respect to the valve, provides a power source with internal resistance. The input circuit of the valve corresponds to the load resistance  $R_A$  of this circuit. Minimum currents and voltages must be available on the valve in order for the valve to switch correctly. The voltage  $U_{RL}$  drops across the cable resistance  $R_L$  due to the current  $I_{RA}$ , which is the same throughout.

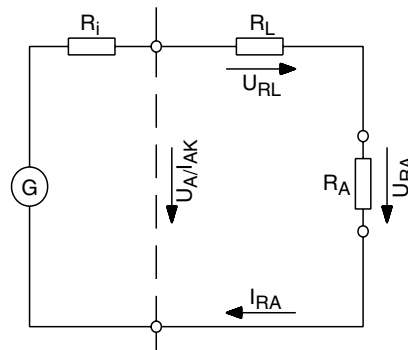

- G: Generator
- R<sub>i</sub>: Internal resistor
- R<sub>L</sub>: Lead resistance
- R<sub>A</sub>: Load resistor
- U<sub>A0</sub>: Quiescent voltage
- U<sub>A</sub>: Output voltage
- U<sub>RL</sub>: Voltage drop on lead resistance
- U<sub>RA</sub>: Voltage drop on load
- U<sub>0</sub>: max. voltage
- I<sub>0</sub>: max. current
- I<sub>AK</sub>: Short-circuit current
- I<sub>RA</sub>: Load current

The **output characteristic** diagram at right shows the generator characteristic and the resistance line of the valve. The difference between the  $U_{RA}$  and the actual output voltage  $U_A$  meets the maximum voltage drop across the cable. From that, the maximum cable length and resistance can be calculated.

However, the calculation does not take into account the requirements per EN 60079-11 (Intrinsic Safety). Therefore, the user should test the system to ensure that maximum values for external inductance and capacitance are not exceeded.

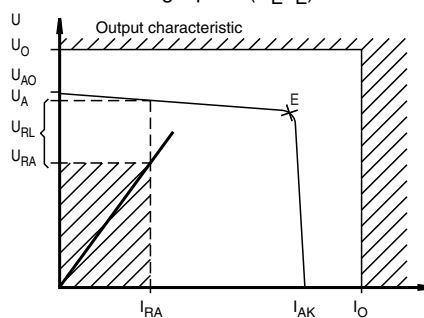
**Output characteristic**E: Curve angle point ( $U_E/I_E$ )

▨ unpermissible area for valves

## Instructions

### 1. Utilisation

- In process measuring and control technology, the connecting modules are used to transfer binary signals within potentially explosive areas and from potentially explosive areas into non-explosive areas.
- The data sheets of individual devices contain the electrical data for the EC Declaration of Conformity and has to be considered as an essential component of the instruction manual.
- The outputs are built to conform with protection class "Intrinsic Safety i", the BUS conforms to protection class "Increased Safety e", and the I/O modules themselves conform to protection class "Encapsulation m".
- Laws and/or regulations governing the use or intended usage have to be observed.
- Devices that are operated in general electrical systems must not be operated in electrical systems subsequently that are connected with potentially explosive areas.
- The I/O modules are not suitable to separate signals in power engineering. The data sheets of the manufacturer have to be observed.

### 2. Initial operation, installation

(The initial operation and the installation shall be carried out only by specifically trained expert staff.)

- The I/O modules are built to conform with the protection class IP54.
- The I/O modules are suitable for use in hazardous areas of zone 1.
- The intrinsically safe electric circuits (light blue marking on the device) may be passed into hazardous areas, if a safe separation to all non-intrinsically safe electric circuits is ensured, in particular. The installation has to be carried out in keeping with the applicable installation regulations.
- If the intrinsically-safe electric circuits are used in a potentially dust explosive area "D", field devices may be used only which have been approved for this kind of application.
- When intrinsically-safe field devices are connected up to the intrinsically-safe electric circuits of the I/O modules, the respectively applicable maximum values of the field device and of the I/O module have to be observed in keeping with the explosion protection (proof of inherent safety). The provisions of EN 6007914/IEC 6007914 have to be observed in this regard. The "National Foreword" of DIN EN 6007914/VDE 0165 Part 1 also has to be observed for the Federal Republic of Germany.
- The EC Declarations of Conformity and/or the EC Type Approval Certificates have to be observed. The adherence to the "Special Conditions" mentioned is especially important.
- The device may be installed directly on the wall.

### 3. Servicing, maintenance

- The transfer characteristics of the devices remain stable, even over long periods of time, thus eliminating the need for regular adjustment. Maintenance is therefore not required.

### 4. Fault clearance

- Devices, which are operated in hazardous areas, must not be modified. Repairs on the device may only be performed by specialists who have been trained and authorised specifically for the task.