



Model Number

UB2000-F54-E4-V15

Single head system

Features

- **Switch output**
- **5 different output functions can be set**
- **Program input**
- **Synchronization options**
- **Deactivation option**
- **Temperature compensation**

Diagrams

Characteristic response curve

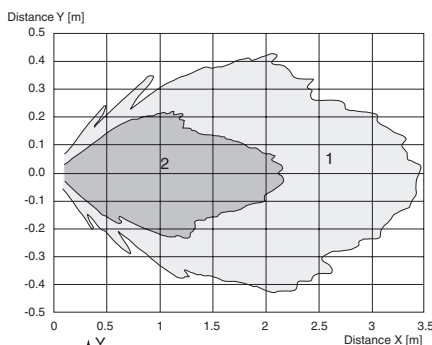

Curve 1: flat surface 100 mm x 100 mm
Curve 2: round bar, Ø 25 mm

Release date: 2011-08-16 09:04 Date of issue: 2013-10-25 108161_eng.xml

Technical data

| | |
|---|---|
| General specifications | |
| Sensing range | 80 ... 2000 mm |
| Adjustment range | 100 ... 2000 mm |
| Unusable area | 0 ... 80 mm |
| Standard target plate | 100 mm x 100 mm |
| Transducer frequency | approx. 175 kHz |
| Response delay | ≤ 150 ms |
| Indicators/operating means | |
| LED green | solid green: monitoring system green flashing: program function |
| LED yellow | indication of the switching state flashing: program function object detected |
| LED red | flashing: normal mode: error Program function: no object detected permanently: Program mode, object uncertain |
| Electrical specifications | |
| Operating voltage U_B | 10 ... 30 V DC , ripple 10 % _{SS} |
| No-load supply current I_0 | ≤ 55 mA |
| Input/Output | |
| Synchronization | 1 synchronous input 0-level: $-U_B \dots +1$ V 1-level: $+4$ V $\dots +U_B$ input impedance: > 12 KOhm synchronization pulse: 0,1 ... 28 ms |
| Synchronization frequency | ≤ 33 Hz |
| Common mode operation | ≤ 33 Hz |
| Multiplex operation | ≤ 33 / n Hz, n = number of sensors |
| Input | |
| Input type | 1 program input, switching point A1: $-U_B \dots +1$ V, switching point A2: $+4$ V $\dots +U_B$ input impedance: > 4.7 kΩ, program pulse: ≥ 1 s |
| Output | |
| Output type | 1 switch output E4, NPN, NO/NC |
| Rated operating current I_e | 200 mA , short-circuit/overload protected |
| Voltage drop U_d | ≤ 3 V |
| Repeat accuracy | ≤ 1 % of full-scale value |
| Switching frequency f | max. 3 Hz |
| Range hysteresis H | ≤ 1 % of the set operating distance |
| Temperature influence | ± 1.5 % of full-scale value |
| Ambient conditions | |
| Ambient temperature | -25 ... 70 °C (-13 ... 158 °F) |
| Storage temperature | -40 ... 85 °C (-40 ... 185 °F) |
| Mechanical specifications | |
| Connection type | Connector M12 x 1 , 5-pin |
| Protection degree | IP65 |
| Material | |
| Housing | ABS |
| Transducer | epoxy resin/hollow glass sphere mixture; polyurethane foam |
| Mass | 100 g |
| Compliance with standards and directives | |
| Standard conformity | |
| Standards | EN 60947-5-2:2007 IEC 60947-5-2:2007 |

| | |
|-----------------------------------|--|
| Approvals and certificates | |
| UL approval | cULus Listed, General Purpose |
| CSA approval | cCSAus Listed, General Purpose |
| CCC approval | CCC approval / marking not required for products rated ≤36 V |

Dimensions

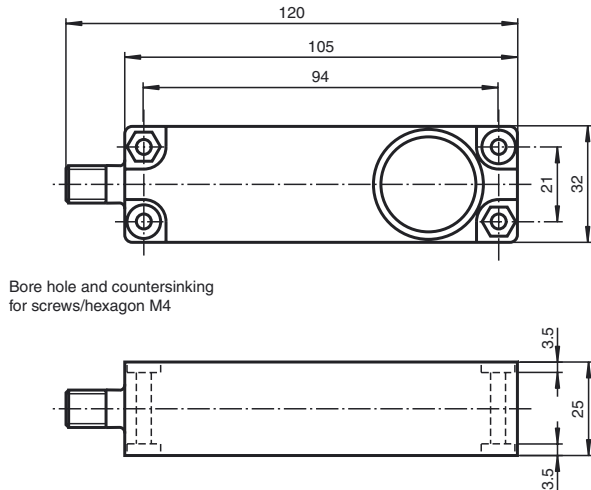

Electrical Connection

Standard symbol/Connections:
(version E4, npn)

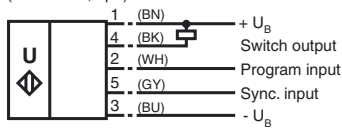

Wire colors in accordance with EN 60947-5-2.

Pinout

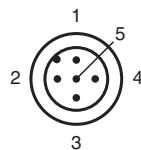

Wire colors in accordance with EN 60947-5-2

| | | |
|---|----|---------|
| 1 | BN | (brown) |
| 2 | WH | (white) |
| 3 | BU | (blue) |
| 4 | BK | (black) |
| 5 | GY | (gray) |

Additional Information

Programmable output modes

- Window mode, normally open mode
A1 < A2:
- Window mode, normally closed mode
A2 < A1:
- One switch point, normally open mode
A1 -> ∞:
- One switch point, normally closed mode
A2 -> ∞:
- A1 -> ∞, A2 -> ∞: Object presence detection mode
Object detected: Switch output closed
No object detected: Switch output open

Accessories

UB-PROG2

Programming unit

V15-G-2M-PVC

Female cordset, M12, 5-pin, PVC cable

V15-W-2M-PUR

Female cordset, M12, 5-pin, PUR cable

Synchronisation

The sensor features a synchronisation input for the suppression of mutual interference. If this input is not used, the sensor will operate using an internally generated clock rate. The synchronisation of multiple sensors can be realised as follows:

External synchronisation

The sensor can be synchronised by the external application of a square wave voltage. A synchronisation pulse at the synchronisation input starts a measuring cycle. The pulse must have a duration greater than 100 µs. The measuring cycle starts with the falling edge of a synchronisation pulse. A low level > 1 s or an open synchronisation input will result in the normal operation of the sensor. A high level at the synchronisation input disables the sensor.

Two operating modes are available

1. Multiple sensors can be controlled by the same synchronisation signal. The sensors are synchronised.
2. The synchronisation pulses are sent cyclically to individual sensors. The sensors operate in multiplex mode.

Internal synchronisation

The synchronisation connections of up to 5 sensors capable of internal synchronisation are connected to one another. When power is applied, these sensors will operate in multiplex mode. The response delay increases according to the number of sensors to be synchronised. Synchronisation cannot be performed during TEACH-IN and vice versa. The sensors must be operated in an unsynchronised manner to teach the switching point.

Note:

If the option for synchronisation is not used, the synchronisation input has to be connected to ground (0V) or the sensor has to be operated via a V1 cable connector (4-pin).

Adjusting of switching points

The ultrasonic sensor features a switch output with two teachable switching points. These are set by applying the supply voltage $-U_B$ or $+U_B$ to the TEACH-IN input. The supply voltage must be applied to the TEACH-IN input for at least 1 s. LEDs indicate whether the sensor has recognised the target during the TEACH-IN procedure. Switching point A1 is taught with $-U_B$, A2 with $+U_B$.

Five different output functions can be set

1. Window mode, normally-open function
2. Window mode, normally-closed function
3. One switching point, normally-open function
4. One switching point, normally-closed function
5. Detection of object presence

TEACH-IN window mode, normally-open function

- Set target to near switching point
- TEACH-IN switching point A1 with $-U_B$
- Set target to far switching point
- TEACH-IN switching point A2 with $+U_B$

TEACH-IN window mode, normally-closed function

- Set target to near switching point
- TEACH-IN switching point A2 with $+U_B$
- Set target to far switching point
- TEACH-IN switching point A1 with $-U_B$

TEACH-IN one switching point, normally-open function

- Set target to near switching point
- TEACH-IN switching point A2 with $+U_B$
- Cover sensor with hand or remove all objects from sensing range
- TEACH-IN switching point A1 with $-U_B$

TEACH-IN one switching point, normally-closed function

- Set target to near switching point
- TEACH-IN switching point A1 with $-U_B$
- Cover sensor with hand or remove all objects from sensing range
- TEACH-IN switching point A2 with $+U_B$

TEACH-IN detection of object presence

- Cover sensor with hand or remove all objects from sensing range
- TEACH-IN switching point A1 with $-U_B$
- TEACH-IN switching point A2 with $+U_B$

Default setting of switching points

Release date: 2011-06-16 09:04 Date of issue: 2013-10-25 108161_eng.xml

Refer to "General Notes Relating to Pepperl+Fuchs Product Information".

Pepperl+Fuchs Group
www.pepperl-fuchs.com

USA: +1 330 486 0001
fa-info@us.pepperl-fuchs.com

Germany: +49 621 776 4411
fa-info@de.pepperl-fuchs.com

Singapore: +65 6779 9091
fa-info@sg.pepperl-fuchs.com

A1 = unusable area

A2 = nominal sensing range

LED Displays

| Displays in dependence on operating mode | Red LED | Yellow LED | Green LED |
|--|---------|-----------------|-----------|
| TEACH-IN switching point: | | | |
| Object detected | off | flashes | flashes |
| No object detected | flashes | off | flashes |
| Object uncertain (TEACH-IN invalid) | on | off | flashes |
| Normal operation | off | switching state | on |
| Fault | flashes | previous state | off |

Release date: 2011-08-16 09:04 Date of issue: 2013-10-25 108161_eng.xml

Refer to "General Notes Relating to Pepperl+Fuchs Product Information".

Pepperl+Fuchs Group
www.pepperl-fuchs.com

USA: +1 330 486 0001
fa-info@us.pepperl-fuchs.com

Germany: +49 621 776 4411
fa-info@de.pepperl-fuchs.com

Singapore: +65 6779 9091
fa-info@sg.pepperl-fuchs.com