

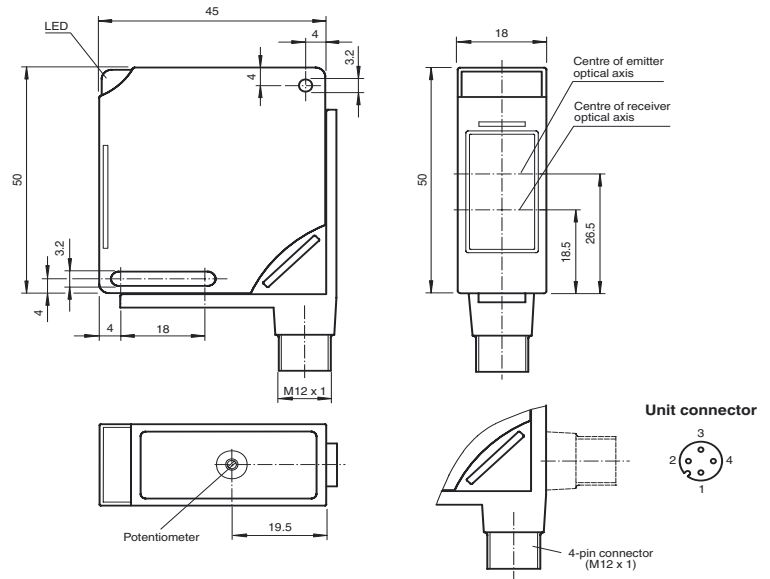

**Dimensions**



**Model Number**

**MLV11-8-500-Ex/40b/112**

Diffuse mode sensor, NAMUR, small housing design, 500 mm detection range, infrared light, light/dark ON, DC version, NAMUR output, M12 plug

**Features**

- ATEX approval for zone 1 (Gas)
- Intrinsically safe, Ex op is ia IIC T6 Gb
- Diffuse mode sensor for standard applications
- Adjustable sensitivity

**Electrical connection**

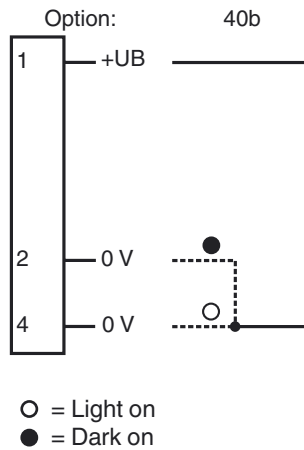

**Pinning according**

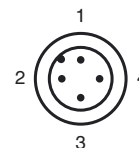

Release date: 2014-04-04 08:32 Date of issue: 2014-04-04 109159\_eng.xml

## Technical data

### General specifications

Detection range	0 ... 500 mm
Adjustment range	180 ... 500 mm
Reference target	standard white 200 mm x 200 mm
Light source	IRED
Light type	modulated infrared light , 860 nm
Ambient light limit	≤ 10000 Lux sun light ≤ 7500 Lux halogen light

### Functional safety related parameters

MTTF <sub>d</sub>	1319 a
Mission Time (T <sub>M</sub> )	20 a
Diagnostic Coverage (DC)	0 %

### Indicators/operating means

Function indicator	LED yellow: switching state
Control elements	Detection range adjuster

### Electrical specifications

Operating voltage	U <sub>B</sub>	6 ... 15.5 V DC (R <sub>i</sub> approx. 0 Ohm)
Ripple		5 %
Power consumption	P <sub>0</sub>	max. 64 mW
Time delay before availability	t <sub>v</sub>	20 ms

### Output

Switching type	light/dark on, programmable	
Signal output	1 NAMUR output NC/NO programmable	
Switching voltage	8 V DC (R <sub>i</sub> approx. 1 kΩ)	
Switching frequency	f	≤ 100 Hz

Reference target detected	connection 1, 2: ≤ 1 mA connection 1, 4: ≥ 2.2 mA
Reference target not detected	connection 1, 2: ≥ 2.2 mA connection 1, 4: ≤ 1 mA

Response time	5 ms
---------------	------

### Ambient conditions

Ambient temperature	-25 ... 70 °C (-13 ... 158 °F)
Storage temperature	-40 ... 80 °C (-40 ... 176 °F)

### Mechanical specifications

Degree of protection	IP67
Connection	V1 connector (M12 x 1), 4-pin, rotatable through 90°
Material	
Housing	PBT
Optical face	scratch resistant plastic lens
Mass	60 g

### Compliance with standards and directives

Standard conformity	
Product standard	EN 60947-5-2

Standards	DIN EN 60947-5-6
-----------	------------------

### Approvals and certificates

CCC approval	CCC approval / marking not required for products rated ≤36 V
Approvals	CE

## Curves / Diagrams

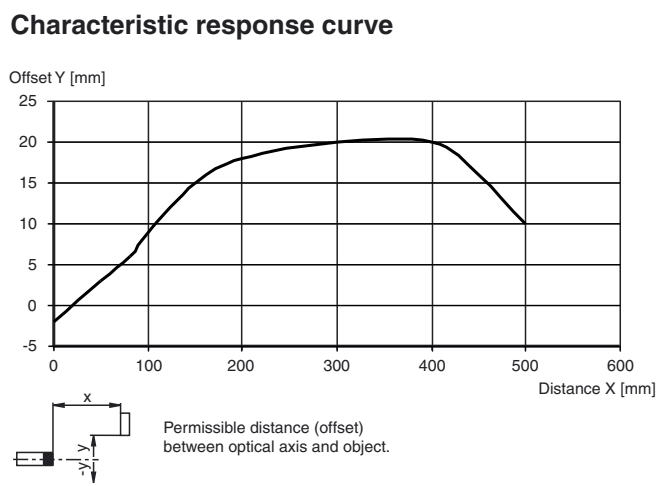

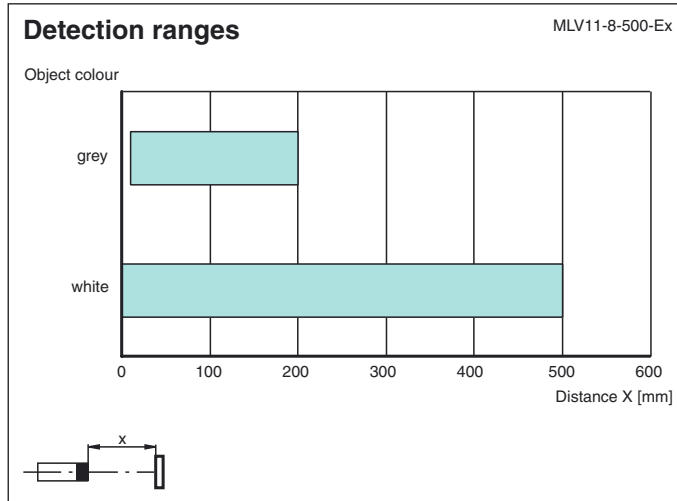

Release date: 2014-04-04 08:32 Date of issue: 2014-04-04 109159\_eng.xml

Refer to "General Notes Relating to Pepperl+Fuchs Product Information".

Pepperl+Fuchs Group  
www.pepperl-fuchs.com

USA: +1 330 486 0001  
fa-info@us.pepperl-fuchs.com

Germany: +49 621 776 4411  
fa-info@de.pepperl-fuchs.com

Singapore: +65 6779 9091  
fa-info@sg.pepperl-fuchs.com