



Model Number

KT9-50/25/103/115

Diffuse mode sensor
with 2 m fixed cable

Features

- High operating distance up to 50 mm
- Very small housing
- Complete device, no amplifier needed
- Voltage range 10 V ... 30 V DC, output current 100 mA short-circuit protected
- Optical parts made of glass, easy cleaning
- Protection degree IP67

Dimensions

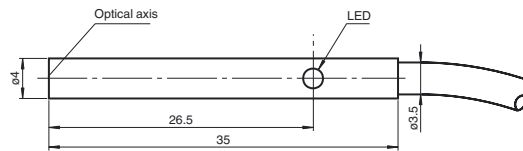

Electrical connection

Option: 103

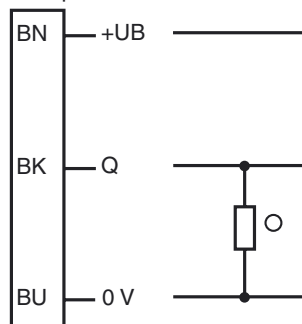

- = Light on
- = Dark on

Technical data**General specifications**

Detection range	0 ... 50 mm
Reference target	standard white, 100 mm x 100 mm
Light source	LED
Light type	modulated infrared light
Optical face	frontal
Ambient light limit	10000 Lux

Indicators/operating means

Function display	switching state, LED yellow
------------------	-----------------------------

Electrical specifications

Operating voltage	U_B	10 ... 30 V DC
Ripple		10 %
No-load supply current	I_0	≤ 15 mA
Time delay before availability	t_v	≤ 20 ms

Output

Switching type	light on	
Signal output	1 switch output PNP	
Switching voltage	max. 30 V DC	
Switching current	max. 100 mA	
Switching frequency	f	≤ 250 Hz
Response time		≤ 3 ms

Ambient conditions

Ambient temperature	0 ... 55 °C (32 ... 131 °F)
---------------------	-----------------------------

Mechanical specifications

Protection degree	IP67
Connection	2 m, 3 x 0.14 mm ² , PVC cable
Material	
Housing	Stainless steel 1.4305 / AISI 303
Optical face	Scratch resistant mineral glass lens
Mass	38 g

Compliance with standards and directives

Standard conformity	
Product standard	EN 60947-5-2:2007 IEC 60947-5-2:2007

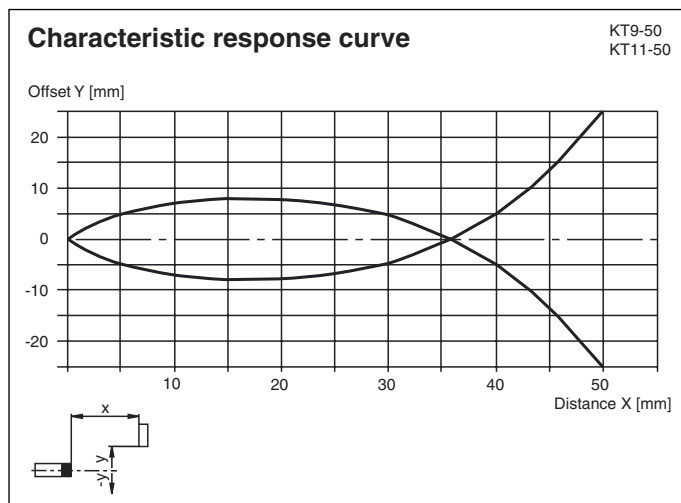
Curves/Diagrams

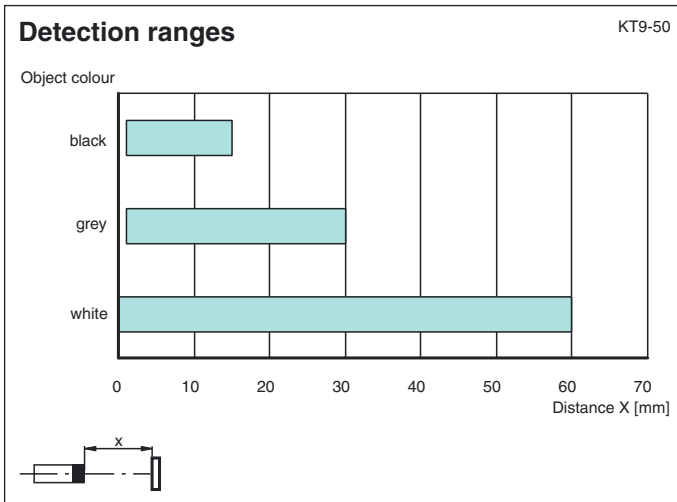
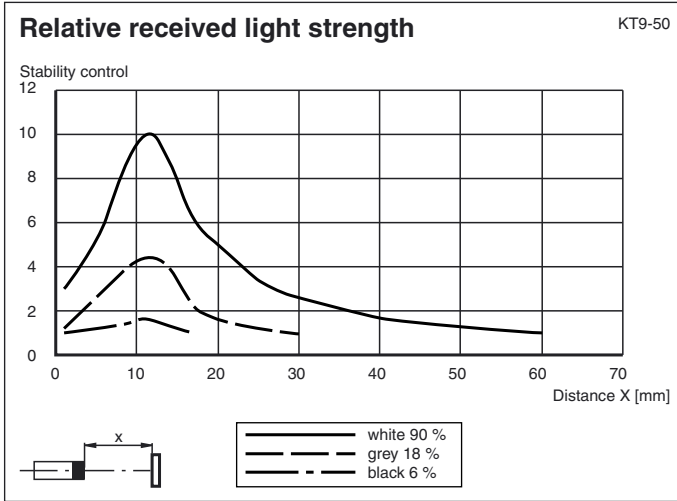

Release date: 2012-12-11 11:54 Date of issue: 2012-12-11 11:54 118343_eng.xml