



Model Number

SLA29/73c

Safety thru-beam sensor
with 4-pin, M12 connector

Features

- Detection range up to 30 m
- Self-monitoring (type 4 according to IEC/EN 61496-1)
- Red transmission light
- Integrated alignment aid
- Clearly visible LED functional display and pre-fault indicator on the receiver
- Sturdy housing
- Waterproof, protection class IP67
- Operation on control units of series SB4 (SafeBox) and SC4-2

Accessories

OMH-05

Mounting aid

OMH-21

Mounting aid

OMH-22

Mounting aid

OMH-MLV11-K

Mounting aid

BA SLA28

Mounting aid Safety

MS SLP/SLA28

Mounting aid Safety

MS SLPCM

Mounting aid Safety

SLA-1-M

Additional accessories can be found in the Internet.

Release date: 2009-12-14 11:10 Date of issue: 2009-12-14 11:18:439_ENG.xml

Dimensions

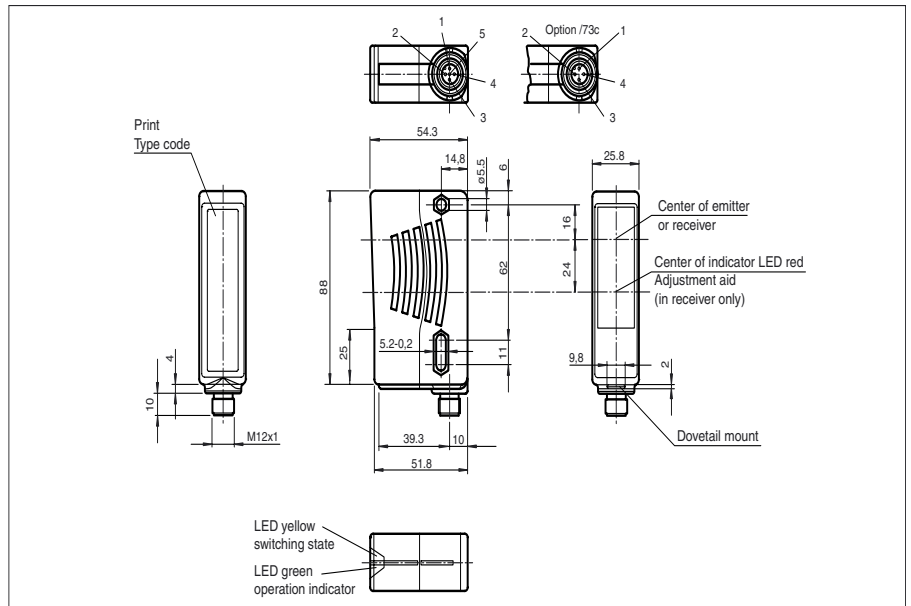

Electrical connection

Design with connector

Receiver:

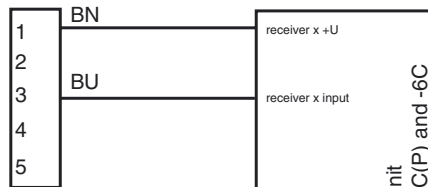

Emitter:

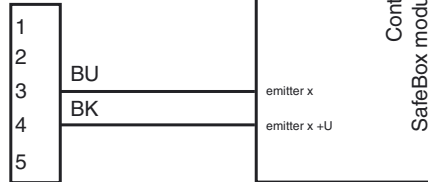

Design with connector

Receiver:

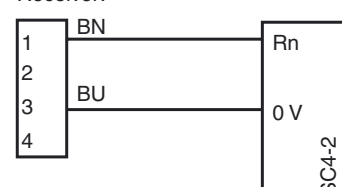

Emitter:

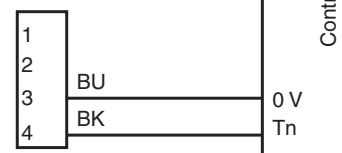

Pinout

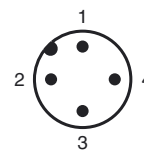

Technical data

General specifications

Effective detection range	0.2 ... 30 m
Threshold detection range	40 m
Light source	LED
Light type	red, modulated light
Approvals	TÜV
Tests	IEC/EN 61496
Safety type according to IEC/EN 61496	4
Marking	CE
Obstacle size	static: 30 mm dynamic: 40 mm (at v = 1.6 m/s of the obstacle)
Alignment aid	LED red in receiver
Angle of divergence	< 5 °

Functional safety related parameters

Safety Integrity Level (SIL)	SIL 3
Performance level (PL)	PL e
Category	Cat. 4
Mission Time (T _M)	20 a
PFH _d	4.4 E-10

Indicators/operating means

Operating display	LED green
Function display	LED yellow: 1. LED lits constantly: signal > 2 x switching point (function reserve) 2. LED flashes: signal between 1 x switching point and 2 x switching point 3. LED off: signal < switching point

Electrical specifications

Operating voltage	U _B	Power supply via control unit
-------------------	----------------	-------------------------------

Ambient conditions

Ambient temperature	-20 ... 60 °C (253 ... 333 K)
Storage temperature	-20 ... 70 °C (253 ... 343 K)
Relative humidity	max. 95 %, not condensing

Mechanical specifications

Protection degree	IP67 according to EN 60529
Connection	M12 connector, 4-pin
Material	
Housing	ABS plastic, RLA 1021 (yellow) painted
Optical face	Plastic pane
Mass	per device 70 g

General information

System components	
Emitter	SLA29-T/73c
Receiver	SLA29-R/73c

Curves/Diagrams

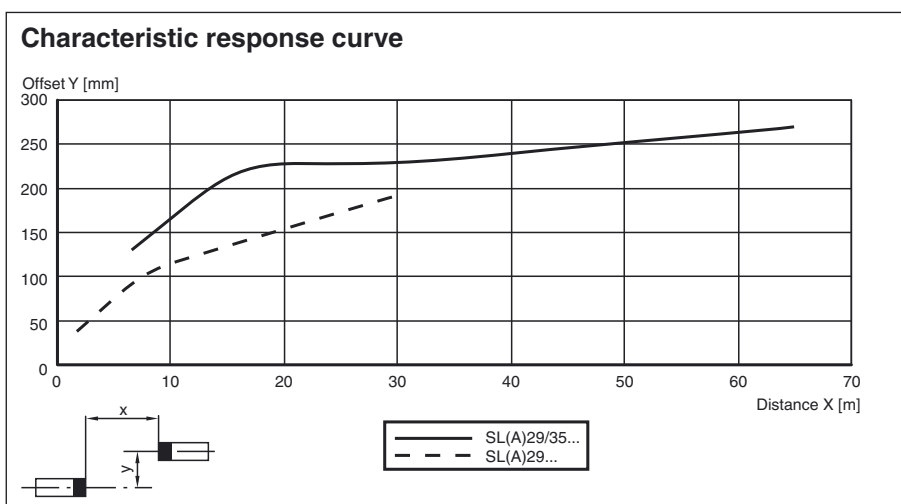

Release date: 2009-12-14 11:10 Date of issue: 2009-12-14 11:18439_ENG.xml

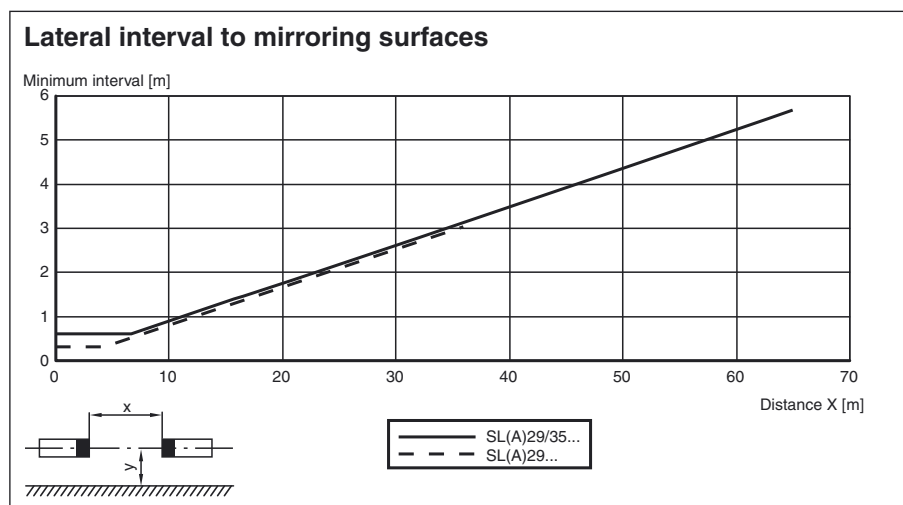
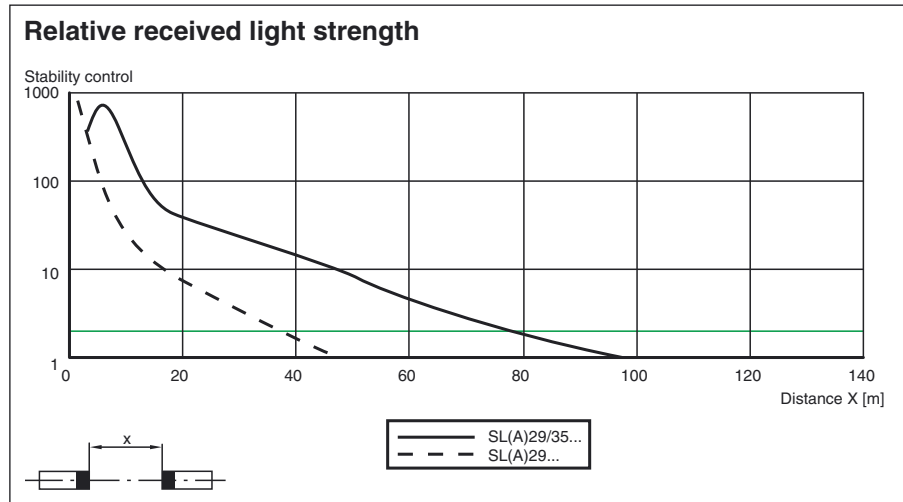

Additional information

For much easier alignment even for long distance applications, an additional red LED is located in the receivers optics:

- LED constantly illuminated:
signal strength < switching level
- LED flashes:
signal strength is between 1-fold switching level and 2-fold switching level
- LED off:
signal strength \geq 2-fold switching level (function reserve)

System accessories

Control units

- SC4-2
- SB4 (SafeBox)

Cable sockets

Option /73c:

- straight: V1-G-2M-PVC
V1-G-5M-PVC
V1-G-10M-PVC
- angled: V1-W-2M-PVC
V1-W-5M-PVC
V1-W-10M-PVC

Option /105:

Release date: 2009-12-14 11:10 Date of issue: 2009-12-14 11:10 118439_ENG.xml

straight: V15-G-2M-PVC
V15-G-5M-PVC
V15-G-10M-PVC
angled: V15-W-2M-PVC
V15-W-5M-PVC
V15-W-10M-PVC

Option /116: no

Mounting aids

OMH-21
OMH-22
OMH-05
OMH-MLV11-K

Further accessories

Laser alignment aid
BA SLA28

Muting Set
MS SLP/SLA28

Redirection mirror
SLA-1-M