



Model Number

MLV12-54-LAS/76b/95/110

Retroreflective sensor
with 4-pin M8 connector, 90° adjustable
position

Features

- Series of sensors in a widely used standard housing
- Visible red light, pulsed LASER light
- Precision: high degree of repeatability thanks to small light spot
- Objects can be reliably detected down to 0 mm: no blind zone
- Resistant against noise: reliable operation under all conditions
- High level of stability thanks to the metal housing frame

Dimensions

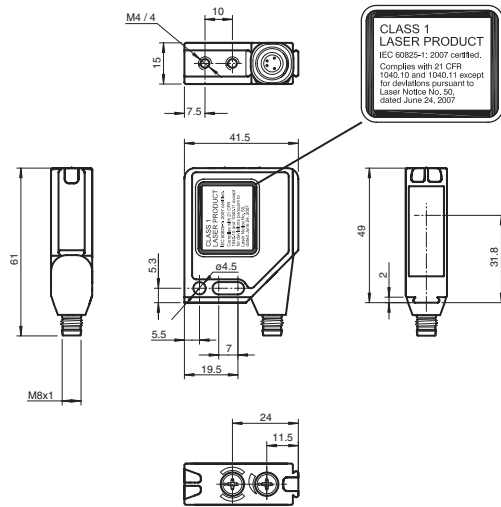

Electrical connection

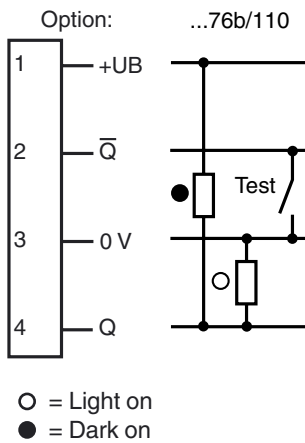

Pinout



Indicators/operating means

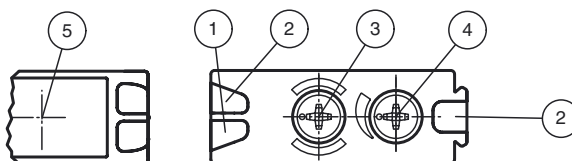

1	Operating display green
2	Switch state yellow
3	Bright/dark switch
4	Potentiometer
5	Optical axis

Release date: 2013-04-18 16:46 Date of issue: 2013-05-13 128103_eng.xml

Refer to "General Notes Relating to Pepperl+Fuchs Product Information".

Pepperl+Fuchs Group
www.pepperl-fuchs.com

USA: +1 330 486 0001
fa-info@us.pepperl-fuchs.com

Germany: +49 621 776 4411
fa-info@de.pepperl-fuchs.com

Singapore: +65 6779 9091
fa-info@sg.pepperl-fuchs.com

Technical data**General specifications**

Effective detection range	0 ... 15 m
Reflector distance	0 ... 15 m
Threshold detection range	21 m
Reference target	MH82 reflector
Light source	laser diode
Light type	modulated visible red light
Laser nominal ratings	
Note	LASER LIGHT , DO NOT STARE INTO BEAM
Laser class	1
Wave length	650 nm
Beam divergence	< 1.5 mrad
Pulse length	1.8 µs
Repetition rate	17.86 kHz
max. pulse energy	6.7 nJ
Diameter of the light spot	approx. 5 mm x 12 mm at 15 m detection range
Angle of divergence	0.02 °
Ambient light limit	
Continuous light	50000 Lux
Modulated light	5000 Lux

Functional safety related parameters

MTTF _d	930 a
Mission Time (T _M)	10 a
Diagnostic Coverage (DC)	90 %

Indicators/operating means

Operating display	LED green, flashes in case of short-circuit
Function display	2 LEDs yellow, light up when light beam is free, flash when falling short of the stability control, off when light beam is interrupted
Controls	rotary switch for light/dark, sensitivity adjuster

Electrical specifications

Operating voltage	U _B	10 ... 30 V DC
Ripple		max. 10 %
No-load supply current	I ₀	max. 40 mA

Input

Test input	emitter deactivation at 0 V
------------	-----------------------------

Output

Switching type	light/dark on switchable	
Signal output	1 push-pull (4 in 1) output, short-circuit protected, reverse polarity protected	
Switching voltage	max. 30 V DC	
Switching current	max. 0.1 A	
Voltage drop	U _d	≤ 2.5 V DC
Switching frequency	f	2500 Hz
Response time		0.2 ms

Ambient conditions

Ambient temperature	-10 ... 50 °C (14 ... 122 °F)
Storage temperature	-20 ... 65 °C (-4 ... 149 °F)

Mechanical specifications

Protection degree	IP67
Connection	4-pin M8 metal connector, 90° rotatable
Material	
Housing	Frame: nickel plated, die cast zinc, Laterals: glass-fiber reinforced plastic PC
Optical face	Plastic pane
Mass	60 g

Compliance with standards and directives

Standard conformity	
Product standard	EN 60947-5-2:2007 IEC 60947-5-2:2007
Shock and impact resistance	IEC / EN 60068. half-sine, 40 g in each X, Y and Z directions
Vibration resistance	IEC / EN 60068-2-6. Sinus. 10 -150 Hz, 5 g in each X, Y and Z directions
Laser class	IEC 60825-1:2007 Complies with 21 CFR 1040.10 and 1040.11 except for deviations pursuant to Laser Notice No. 50, dated June 24, 2007

Approvals and certificates

UL approval	cULus Listed, Type 1 enclosure
CCC approval	CCC approval / marking not required for products rated ≤36 V

Accessories**OMH-MLV12-HWG**

Mounting bracket for series MLV12 sensors

OMH-MLV12-HWK

Mounting bracket for series MLV12 sensors

OMH-K01

dove tail mounting clamp

OMH-K02

dove tail mounting clamp

OMH-K03

dove tail mounting clamp

OMH-01

Mounting aid for round steel ø 12 mm or sheet 1.5 mm ... 3 mm

OMH-06

Mounting aid for round steel ø 12 mm or sheet 1.5 mm ... 3 mm

REF-MH82

Reflector with Micro-structure, rectangular 82 mm x 60 mm, mounting holes

REF-MH50

Reflector with Micro-structure, rectangular 50.9 mm x 50.9 mm, mounting holes, fixing strap

REF-MH78

Reflector with Micro-structure, hexagonal 78 mm x 61 mm, mounting holes

REF-MH20

Reflector with Micro-structure, rectangular 32 mm x 20 mm, mounting holes

REF-MA21

Reflector with Micro-structure, round ø 21 mm, self-adhesive

Other suitable accessories can be found at www.pepperl-fuchs.com

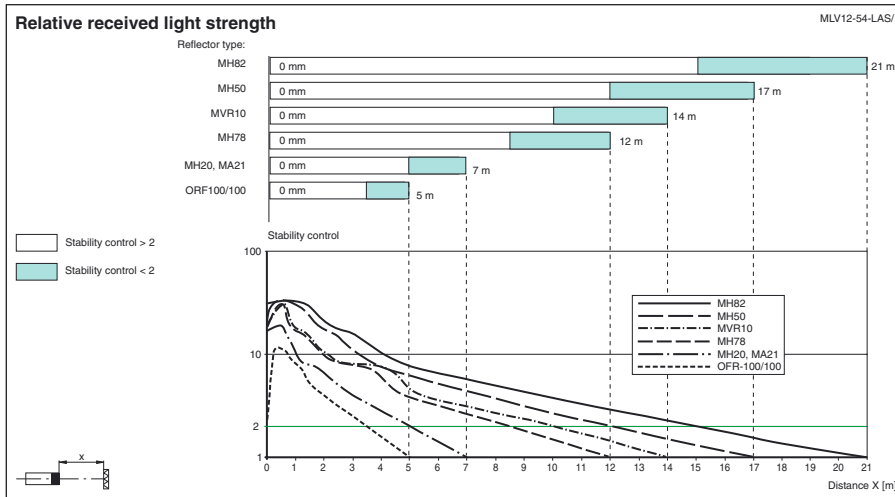

Curves/Diagrams

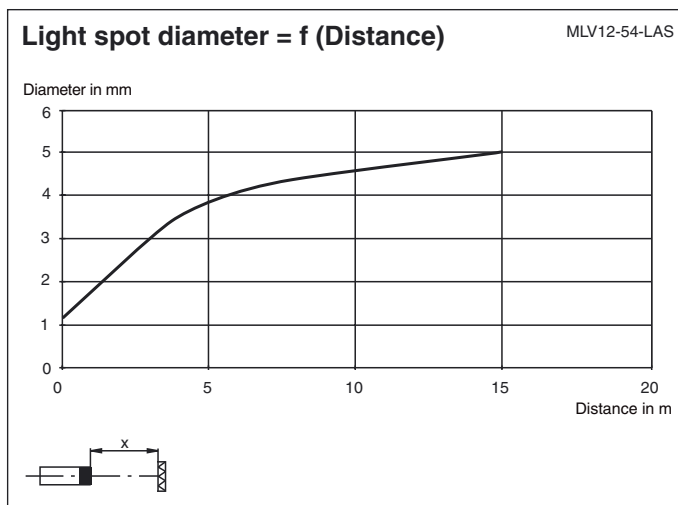

Laser notice laser class 1

- The irradiation can lead to irritation especially in a dark environment. Do not point at people!
- Maintenance and repairs should only be carried out by authorized service personnel!
- Attach the device so that the warning is clearly visible and readable.
- The warning accompanies the device and should be attached in immediate proximity to the device.
- Caution – Use of controls or adjustments or performance of procedures other than those specified herein may result in hazardous radiation exposure.

Release date: 2013-04-18 16:46 Date of issue: 2013-05-13 128103_eng.xml

Refer to "General Notes Relating to Pepperl+Fuchs Product Information".

Pepperl+Fuchs Group
www.pepperl-fuchs.com

USA: +1 330 486 0001
fa-info@us.pepperl-fuchs.com

Germany: +49 621 776 4411
fa-info@de.pepperl-fuchs.com

Singapore: +65 6779 9091
fa-info@sg.pepperl-fuchs.com