

Model number

VAA-4E4A-KE2-DK

Control cabinet module
Data coupler

Features

- Module for bidirectional data exchange between two AS-Interface circuits
- 2 AS-Interface connections
- 4 inputs/4 outputs per slave (internally connected)
- Housing with removable terminals
- Function display for all outputs
- Communication monitoring
- Addressing via 2 sockets in the front plate

Dimensions

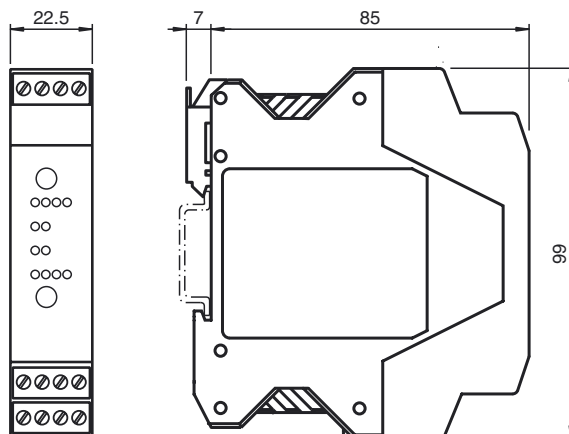

Electrical connection

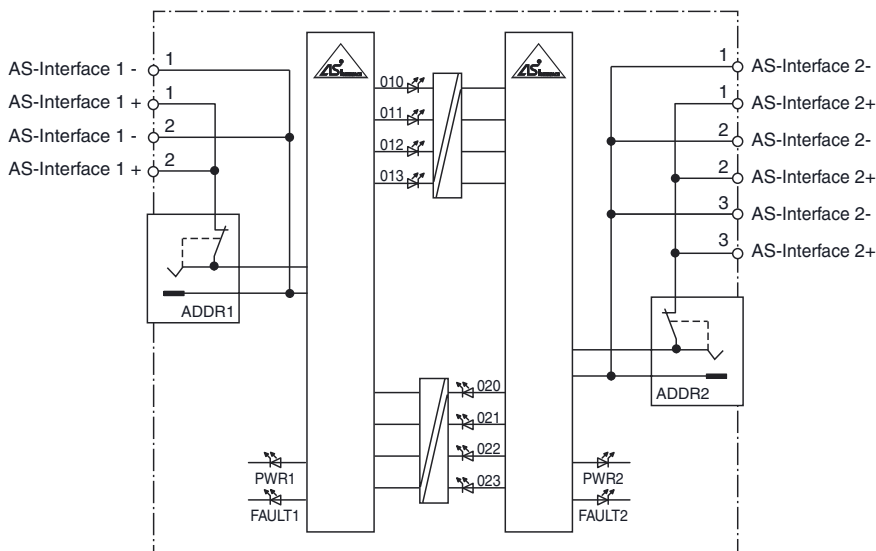

Indicating / Operating means

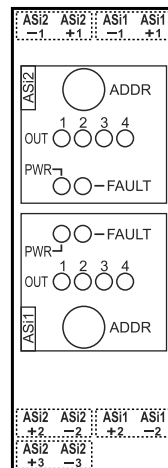

Release date: 2008-08-07 15:50 Date of issue: 2014-01-13 130400_eng.xml

Refer to "General Notes Relating to Pepperl+Fuchs Product Information".

Pepperl+Fuchs Group
www.pepperl-fuchs.com

USA: +1 330 486 0001
fa-info@us.pepperl-fuchs.com

Germany: +49 621 776 4411
fa-info@de.pepperl-fuchs.com

Singapore: +65 6779 9091
fa-info@sg.pepperl-fuchs.com

Technical data**General specifications**

Slave type	Standard slave
AS-Interface specification	V3.0
Required master specification	≥ V2.0

Indicators/operating means

LED FAULT	error display; LED red red: communication error or address is 0 red flashing: overload of outputs
LED PWR	AS-Interface voltage; 2 LED green
LED OUT	Switching state (output); 8 LED yellow O10-O13: AS-Interface 1; O20-O23: AS-Interface 2

Electrical specifications

Rated operating voltage	U_e	26.5 ... 31.6 V from AS-Interface
Rated operating current	I_e	≤ 80 mA

Input

Number/Type	4 internal inputs per AS-Interface circuit 1+2
-------------	--

Output

Number/Type	4 internal outputs per AS-Interface circuit 1+2
-------------	---

Programming instructions

Profile	S-7.F.F
IO code	7
ID code	F
ID1 code	F
ID2 code	E

Data bits (function via AS-Interface)
The output of AS-Interface 1 is the input to AS-Interface 2
The output of AS-Interface 2 is the input to AS-Interface 1

	input	output
D0	IN1	O1
D1	IN2	O2
D2	IN3	O3
D3	IN4	O4

Parameter bits (programmable via AS-i) **function**

P0	not used
P1	not used
P2	not used
P3	not used

Ambient conditions

Ambient temperature	0 ... 55 °C (32 ... 131 °F)
Storage temperature	-25 ... 85 °C (-13 ... 185 °F)

Mechanical specifications

Protection degree	IP20
Connection	removable terminals, terminal connection ≤ 2.5 mm ²
Material	
Housing	PA 66-FR
Mass	130 g
Mounting	DIN mounting rail

Compliance with standards and directives

Directive conformity	
EMC Directive 2004/108/EC	EN 61000-6-2:2005, EN 61000-6-4:2001, EN 50295:1999
Standard conformity	
Electromagnetic compatibility	EN 61000-6-2:2005, EN 61000-6-4:2001, EN 50295:1999
Protection degree	EN 60529

Function

The data coupler module VAA-4E4A-KE2-DK is used to exchange data via two AS-Interface circuits. The data coupler itself consists of two 4E4A slaves in a single housing. The output bits of the AS-Interface circuit 1 are represented at the AS-Interface circuit 2 as input bits, and vice versa. This permits a bidirectional data exchange without the need to transfer the data via an overriding control. This is a particular advantage in time-critical applications. The addressing of both integrated AS-Interface slaves is mutually independent. Two addressing jacks are available on the front panel.

By using two independent AS-Interface connections the related inputs and outputs are electrically separated. This prevents problems with potential shifting (mass potential). For status indication each slave has 6 LEDs on the front panel, 4 LEDs for the 4 outputs, 1 LED for the voltage indication, and 1 LED for indicating AS-Interface error messages.

The housing of only 22.5 mm width requires little room in the switch cabinet. The module is installed by snapping it onto the 35 mm mounting rail in accordance with EN 50022.

Connections are made via pluggable screw terminals. This enables the easy disconnection during commissioning or service.

Accessories**VBP-HH1-V3.0-KIT**

AS-Interface Handheld with accessory

VBP-HH1-V3.0

AS-Interface Handheld

VAZ-PK-1,5M-V1-G

Adapter cable module/hand-held programming device