

Dimensions

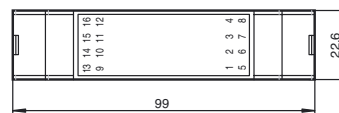
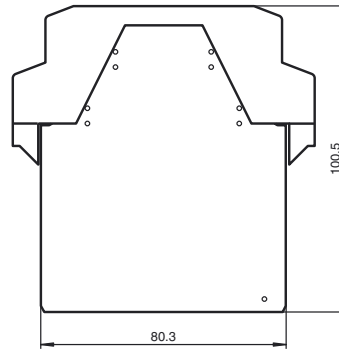

Model Number

SB4 Module 4MD

Safety control unit module

Module for Evaluation unit SafeBox - series SB4

Features

- Muting module
- 4 sensor channels
- Double muting
- Continuous muting with no time limit
- Emergency muting for the correction of the material jam
- Operating mode can be selected by means of DIP switches

Electrical connection

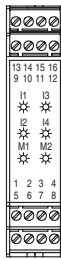

Terminal	Function
1	24 V sensor supply
2	Sensor 2 IN
3	Sensor 4 IN
4	0 V sensor supply
5	24 V sensor supply
6	Sensor 1 IN
7	Sensor 3 IN
8	0 V sensor supply
9	Input override 1
10	24 V override 1
11	24 V override 2
12	Input override 2
13	+24 V DC supply voltage for muting lamps
14	0 V DC supply voltage for muting lamps
15	Output muting lamp 1
16	Output muting lamp 2

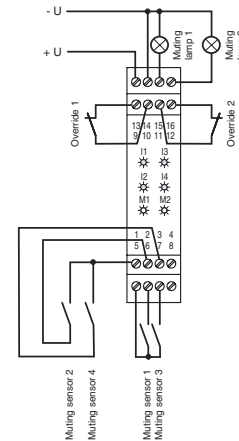

Technical data

General specifications

Operating mode muting operating modes

Functional safety related parameters

Safety Integrity Level (SIL)	SIL 3
Performance level (PL)	PL e
Category	Cat. 4
Mission Time (T _M)	20 a
Type	4

Indicators/operating means

Function display	LED yellow (4x): indicator lamp muting sensor 1 ... 4 LED white (2x): status muting lamp
Controls	DIP-switch

Electrical specifications

Operating voltage U_B 24 V DC ± 20 % ,
24 V DC ± 20 % , via SB4 Housing

Input

Activation current	approx. 10 mA
Activation time	Override-Input 0.4 ... 1.2 s

Output

Switching voltage	24 V
Switching current	7.5 mA ... 500 mA

Ambient conditions

Ambient temperature	0 ... 50 °C (32 ... 122 °F)
Storage temperature	-20 ... 70 °C (-4 ... 158 °F)

Mechanical specifications

Protection degree	IP20
Connection	screw terminals , lead cross section 0.2 ... 2 mm ²

Release date: 2011-06-15 14:41 Date of issue: 2011-06-27 182113_eng.xml

Subject to modifications without notice

Pepperl+Fuchs Group
www.pepperl-fuchs.com

USA: +1 330 486 0001
fa-info@us.pepperl-fuchs.com

Germany: +49 621 776-4411
fa-info@pepperl-fuchs.com

Copyright Pepperl+Fuchs
Singapore: +65 6779 9091
fa-info@sg.pepperl-fuchs.com



Material	
Housing	Polyamide (PA)
Mass	approx. 150 g
Compliance with standards and directives	
Standard conformity	(extract)
Standards	EN IEC 61496-1 EN IEC 61508 EN ISO 13849-1
Approvals and certificates	
SIL classification	up to SIL3 acc. to IEC 61508 tested and certified by TÜV SÜD according to: IEC 61508:1998 part 1, 3.4 IEC 61508: 2000 ISO 13849-1:2006 EN 50178:1997 IEC 61496-1:2004 IEC 61496-2:2006
UL approval	cULus
TÜV approval	TÜV

This module can only be operated within an evaluation device of the SafeBox SB4 type.

The SafeBox instruction manual should be observed.

Function

The muting module realises the muting function for the sensor channels of the four to six channel sensor card module immediately to the right of the module.

The user must make sure to only connect sensors that can be muted to the sensor card that is assigned to the muting module. These are, for example, light barriers or light grids.



Danger!

Emergency off push buttons must not be muted.

This muting module does not monitor the activation time of the muting sensors.

The following must be observed for the application:



Danger!

The access to the protected area is completely blocked by the object which triggers muting. If the muting sensors are activated, it should not be possible to access the hazardous area via the object.



Note

With parallel muting, an application in the category 4 is possible. With sequential muting, only a category 2 can still be reached.

The basis of the assessment of the safety category is that every muting sensor is activated at least once per day (the activation is triggered when the muting procedure is not interrupted).

A detailed description of the muting operating modes can be found in the instruction manual.

Muting sensors

Muting sensors are supposed to detect the muting objects. If an object is detected, the output of the muting sensor switches through its supply voltage. For this purpose, sensors with relay or pnp output are suitable. In a de-energised state, the output of the muting sensor must not be active. The sensor output should be capable of reliably switching a load current of 8 mA at 20 V. Muting sensors with a current consumption of a maximum of 30 mA can be supplied directly from the muting module. Sensors with a higher current consumption require an external power supply. Muting sensors must be selected such that they also work at a supply voltage of at least 12 V.

The cables to the muting sensors must be laid in such a way that no short circuits are possible between the muting sensors.

As muting sensors, the following sensors can be used, for example:

- Retro-reflective sensors dark on or light on (in this case reflector at the object),
- Photoelectric sensors (light on),
- Inductive sensors, mechanical switches.

Settings

The assembly has 8 DIP switches for selecting the different muting operating modes. For selecting functions, 2 selector switches must always be actuated.

Position of the DIP switches

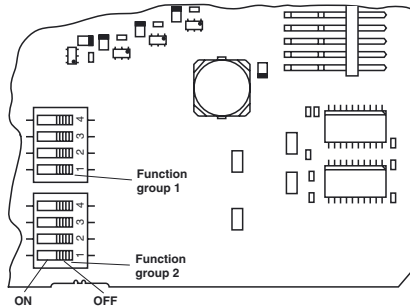

Switch	Position	Operation type
1 Group 1 and 2	OFF	Muting lamp monitoring inactive
	ON	Muting lamp monitoring active
2 Group 1 and 2	OFF	Single muting
	ON	Double muting
3 Group 1 and 2	OFF	The muting sensors can be activated without a time limit
	ON	Before protected area activation, the muting sensors can be activated without a time limit; from protected area activation, muting limited by protection beam
4 Group 1 and 2	OFF	Sequential muting
	ON	Parallel muting

Displays

The muting module has a yellow display for each muting sensor. For each muting lamp there is a white display.

If there is an error in the muting module, only the yellow displays on this assembly will flash.

In the case of an error on the muting lamps, the white muting displays will flash if the muting lamp monitoring is activated.

Display	LED	Meaning
I1 - I4	yellow	Continuous light: muting sensor activated
		Flashing (5 Hz). muting sensor error
M1, M2	white	Continuous light: muting activated
		Flashing (5 Hz). muting lamp error