

Features

- 2-channel
- 230 V AC supply
- 3-wire PNP/NPN sensor or push-pull input
- Relay contact output
- DIP switch selectable functions
- Minimum/maximum control
- Up to SIL2 acc. to IEC 61508

Function

This signal conditioner converts the state of 3-wire sensors (PNP or NPN) or sensors with push-pull output stages into a relay output.

It has two inputs and two form C changeover relay outputs.

The device can be used either as dual channel signal conditioner or as a two-point level controller.

Assembly

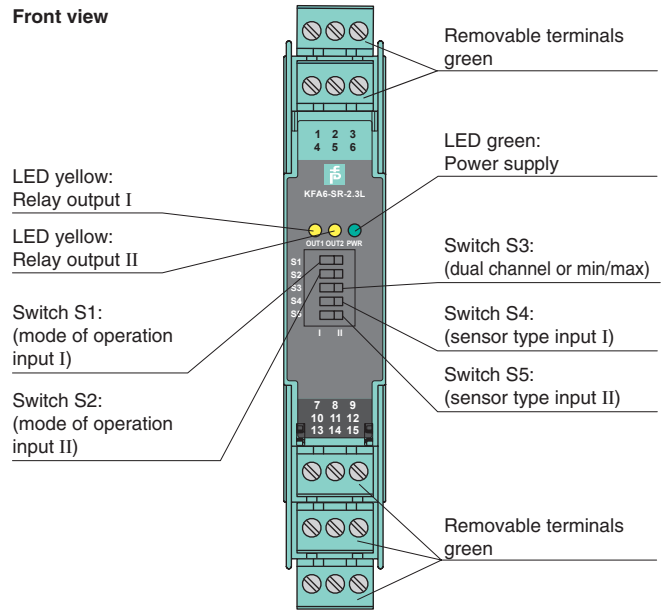

CE

SIL2

Connection

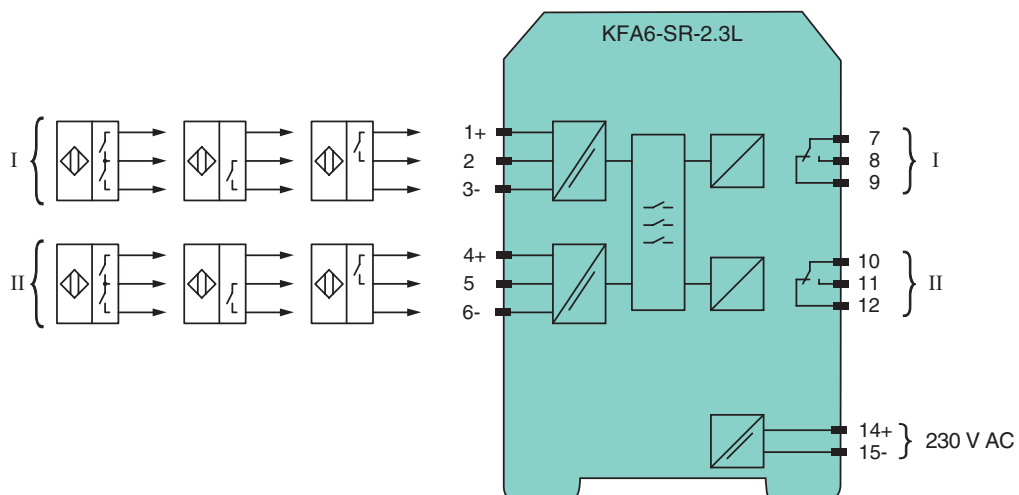

Release date 2010-09-09 10:59 Date of issue 2015-02-16 182509_eng.xml

Refer to "General Notes Relating to Pepperl+Fuchs Product Information".

General specifications		
Signal type		Digital Input
Supply		
Connection		terminals 14, 15
Rated voltage	U_n	90 ... 253 V AC , 45 ... 65 Hz
Rated current	I_n	≤ 150 mA
Power loss		2.5 W
Power consumption		≤ 7 W
Input		
Connection		Input I: terminals 1+, 2, 3-; Input II: terminals 4+, 5, 6-
Rated values		22 ... 24 V DC / 100 mA, see notes
Short-circuit current		110 mA
Switching point		0-signal: < 5 V 1-signal: > 13 V
Output		
Connection		output I: terminals 7, 8, 9 output II: terminals 10, 11, 12
Output I, II		
Contact loading		250 V AC / 4 A / $\cos \phi > 0.7$; 40 V DC / 2 A resistive load
Energized/De-energized delay		max. 6 ms
Mechanical life		10^7 switching cycles
Transfer characteristics		
Switching frequency		≤ 10 Hz
Electrical isolation		
Input/Output		safe galvanic isolation per EN 50178, voltage peak value 253 V
Input/power supply		safe galvanic isolation per EN 50178, voltage peak value 253 V
Output/power supply		safe galvanic isolation per EN 50178, voltage peak value 253 V
Output/Output		basic insulation acc. to EN 50178, rated insulation voltage 253 V _{eff}
Directive conformity		
Electromagnetic compatibility		
Directive 2004/108/EC		EN 61326-1:2006
Low voltage		
Directive 2006/95/EC		EN 50178:1997
Conformity		
Electrical isolation		EN 50178
Electromagnetic compatibility		NE 21
Degree of protection		IEC 60529
Ambient conditions		
Ambient temperature		-20 ... 60 °C (-4 ... 140 °F)
Mechanical specifications		
Degree of protection		IP20
Mass		approx. 150 g
Dimensions		20 x 119 x 115 mm (0.8 x 4.7 x 4.5 in)
General information		
Supplementary information		Statement of Conformity, Declaration of Conformity, Attestation of Conformity and instructions have to be observed where applicable. For information see www.pepperl-fuchs.com .

Release date 2010-09-09 10:59 Date of issue 2015-02-16 182509_eng.xml

Notes

Function

The isolated amplifier has two inputs and two relay outputs (change-over contact) and is usable either as dual channel isolated amplifier or as two-point control (min/max control).

The inputs are designed in a way, that the signals of sensors which have PNP or NPN output transistors as well as push-pull outputs, can be processed. In the case of sensors with push-pull outputs the switches S4 or S5 have to be set to position I. For sensors with PNP or NPN output transistors, the switches S4 or S5 have to be set to position II. The operating behaviour of the sensor can be selected: NO S1/S2 in position I; NC S1/S2 in position II.

Dual channel switching amplifier for binary sensors or contacts

With this function (S3 in position I) contact or sensor signals from the input are transmitted to the relay output.

Parallel operation (1 input, 2 outputs)

A signal duplication can be realized by the following measures:

- Jumper terminal 2 to terminal 5.
- One sensor to input I or II.

Two-point control (min/max control) with storage of status

On this setting (S3 in position II) the information from the two inputs is combined.

When the supply voltage is switched on, relay 1 is energised until input 2 is activated (reset input). Input 1 works as an set input.

Truth table (min/max control)

Conditions	Inputs		Outputs relay I and II
	E I	E II	
Activation of the supply voltage	not activated	not activated	relay energised
	activated	not activated	relay energised
	activated	activated	relay de-energised
Normal operation	activated	transition: not activated/activated	relay de-energising
	transition: activated/not activated	not activated	relay energising

Sensor connection

NPN output/contact

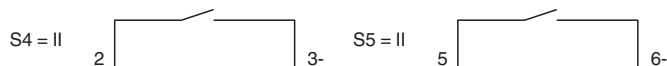

PNP output/contact

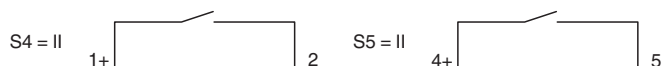

Push-pull output

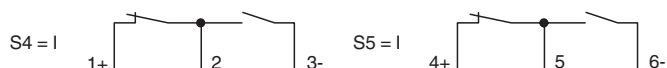

Function of the DIP switches

Function	Switch function	Switch/position
Operating behaviour of the sensor input	input 1 is activated if sensor 1 is closed	S1/I
	input 1 is activated if sensor 1 is open	S1/II
	input 2 is activated if sensor 2 is closed	S2/I
	input 2 is activated if sensor 2 is open	S2/II
Dual channel or min/max	dual channel independent	S3/I
	min/max function with storage of the status	S3/II
Sensor type	input 1: push-pull output stage, NO	S4/I
	input 1: PNP/NPN, NO	S4/II
	input 2: push-pull output stage, NO	S5/I
	input 2: PNP/NPN, NO	S5/II

Release date 2010-09-09 10:59 Date of issue 2015-02-16 182509_eng.xml

Refer to "General Notes Relating to Pepperl+Fuchs Product Information".

Example 1: filling of a vessel (two-point level control, S3 in position II)

Min contact or min sensor is connected to input 1 (set), max contact or max sensor is connected to input 2 (reset). Dip switch S1 and S2 are on position I. A filling pump is connected to output 1 or 2 (terminals 7/8 or 10/11).

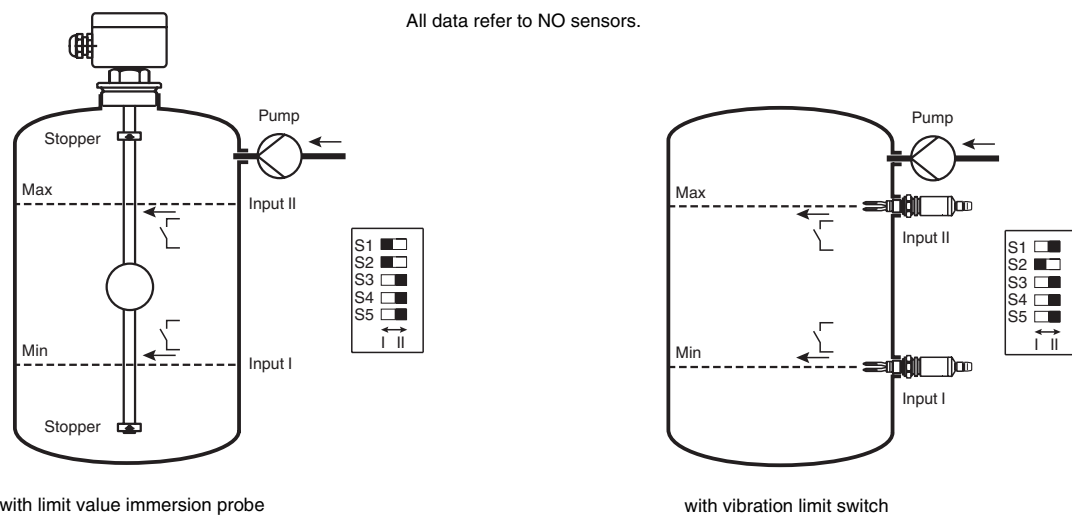

When the supply voltage of the KFA6-SR-2.3L is switched on, the pump will also switched on as long as the Max contact is not activated. During operation the pump is switched off as soon as the level has reached max position. If the level reach min position, the pump is switched on. If the KFA6-SR-2.3L has no power supply, the pump is switched off.

Example 2: emptying of a vessel (two-point level control, S3 in position II)

Max contact or max sensor is connected to input 1 (set), min contact or min sensor is connected to input 2 (reset). Dip switch S1 and S2 are set to position I. An emptying pump is connected to output 1 or 2 (terminals 7/9 or 10/12).

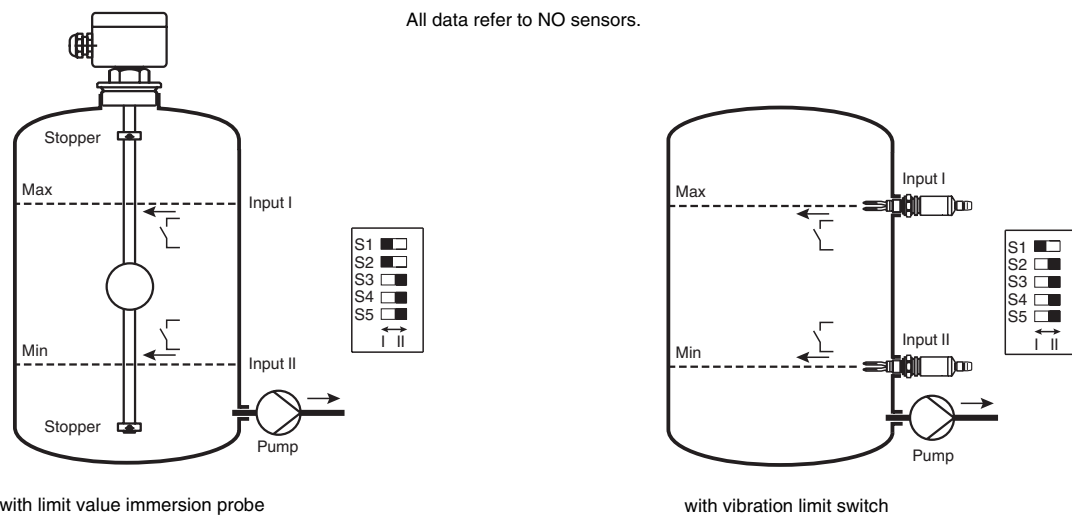

When the supply voltage of the KFA6-SR-2.3L is switched on, the pump will also switched on, if max contact is activated. During operation the pump is switched off as soon as the level has reached min position. If the level reach max position, the pump switched on. If the KFA6-SR-2.3L has no power supply, the pump is switched on.

Comments:

1. NO with push-pull output stage means that the closing contact or transistor is connected to terminal 2 and 3 (5 and 6).
NC with push-pull output stage means that the opening contact or transistor is connected to terminal 2 and 3 (5 and 6).
2. In dip switch position S3/I (dual channel, independent) an output relay is activated if the corresponding input is activated.

Release date 2010-09-09 10:59 Date of issue 2015-02-16 182509_eng.xml

Derating of the sensor currents in dependence of the ambient temperature

The maximum value of the sensor currents is controlled by a thermal overload protection of the device.



Attention

The device determines its ambient temperature and limits the sensor currents accordingly (see figure). An inadmissibly high ambient temperature can limit the function of the sensors.

