



**Model Number**

**MLV41-54-G/25/70/123/136**

Retroreflective sensor  
with 5-pin, M9 x 0.5 connector

**Features**

- Rugged series in corrosion-resistant metal housing
- Reliable recognition of reflective objects and clear glass
- Two machines in one: clear object detection or reflection operating mode with long range
- TEACH-IN switch for setting the contrast detection levels
- Automatic adjustment in case of soiling in contrast detection mode
- Resistant against noise: reliable operation under all conditions

**Product information**

The unique and extremely popular design of the MLV41 series enables it be mounted correctly in confined areas and offers all the functions that are normally only found on larger phototelectric sensors. The MLV41 series comes with a range of functions. For example, highly visible status LEDs on the front and back, resistance to ambient light, crosstalk protection and universally applicable output stages that permit every possible switching logic and polarity to be realized. The enhanced resistance to ambient light ensures reliable operation even where modern energy-saving lamps with electronic ballasts are in use. The same applies where multiple devices are present, i.e. the use of a number of sensors in the same vicinity causes no problems.

Release date: 2013-06-18 15:39 Date of issue: 2013-06-18 183621\_eng.xml

**Dimensions**

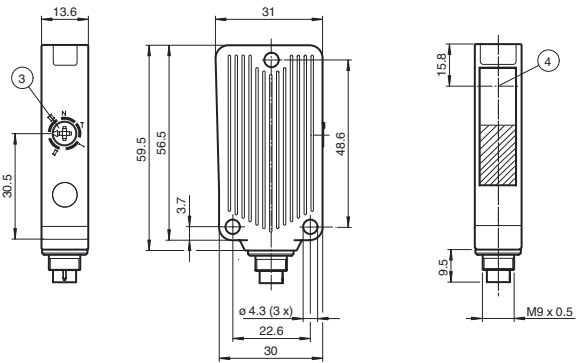

**Electrical connection**

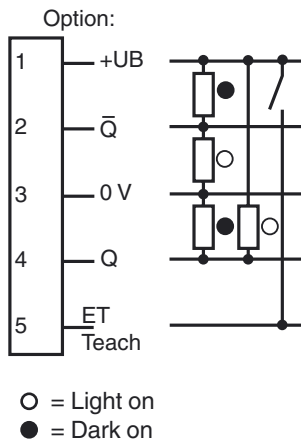

**Pinout**

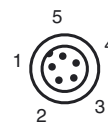

**Indicators/operating means**

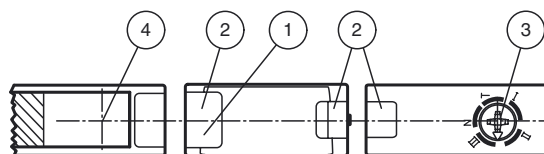

1	Operating display	green
2	Functional display	yellow
3	Teach-In switch	
4	Optical center emitter and receiver	

**Technical data****General specifications**

Effective detection range	0 ... 4 m in TEACH mode 0 ... 5.2 m at switch position "N"
Reflector distance	0 ... 4 m in TEACH mode 0 ... 5.2 m at switch position "N"
Threshold detection range	6.5 m
Reference target	H85-2 reflector
Light source	LED
Light type	modulated visible red light , 660 nm
Angle deviation	max. $\pm 1^\circ$
Diameter of the light spot	approx. 100 mm at detection range 4 m
Angle of divergence	1.5 $^\circ$
Ambient light limit	40000 Lux

**Functional safety related parameters**

MTTF <sub>d</sub>	900 a
Mission Time (T <sub>M</sub> )	20 a
Diagnostic Coverage (DC)	0 %

**Indicators/operating means**

Operating display	LED green, statically lit Power on , Undervoltage indicator: Green LED, pulsing (approx. 0.8 Hz) , short-circuit : LED green flashing (approx. 4 Hz)
Function display	2 LEDs yellow for switching state, stability control, TEACH-IN and contrast detection mode
Controls	5-step switch for setting the contrast detection levels.
Contrast detection levels	10 % - clean, water filled PET bottles 18 % - clear glass bottles 40 % - colored glass or opaque materials adjustable due to TEACH-IN switch

**Electrical specifications**

Operating voltage	U <sub>B</sub>	10 ... 30 V DC
Ripple		max. 10 %
No-load supply current	I <sub>0</sub>	max. 35 mA

**Input**

Function input	Ext. Teach-In input (ET)
----------------	--------------------------

**Output**

Signal output	2 push-pull (4 in 1) outputs, complementary, short-circuit proof, reverse polarity protected	
Switching voltage	max. 30 V DC	
Switching current	max. 100 mA	
Voltage drop	U <sub>d</sub>	$\leq 2.5$ V DC
Switching frequency	f	1000 Hz
Response time		0.5 ms

**Ambient conditions**

Ambient temperature	-40 ... 60 $^\circ$ C (-40 ... 140 $^\circ$ F)
Storage temperature	-40 ... 75 $^\circ$ C (-40 ... 167 $^\circ$ F)

**Mechanical specifications**

Protection degree	IP67
Connection	with M9, 5-pin metal connector
Material	
Housing	aluminum , Delta-Seal coated
Optical face	glass pane
Connector	metal
Mass	50 g

**Compliance with standards and directives**

Directive conformity	
EMC Directive 2004/108/EC	EN 60947-5-2:2007
Standard conformity	
Product standard	EN 60947-5-2:2007 IEC 60947-5-2:2007

**Approvals and certificates**

UL approval	cULus Listed 57M3 (Only in association with UL Class 2 power supply; Type 1 enclosure)
CCC approval	CCC approval / marking not required for products rated $\leq 36$ V

**Accessories****OMH-09**

Mounting bracket for Sensors series MLV41 for M12 rod mounting

**OMH-40**

Mounting bracket

**ASK /70 KL.2000MM**

Female cordset, M9, 5-pin, cable

**ASK /78 KL.2000MM**

Female cordset, M9, 5-pin, cable

Other suitable accessories can be found at [www.pepperl-fuchs.com](http://www.pepperl-fuchs.com)

**Curves/Diagrams**

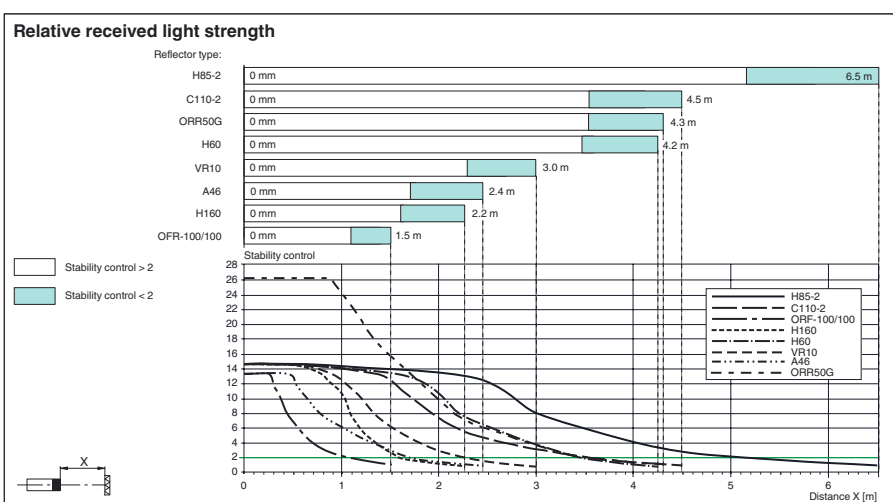
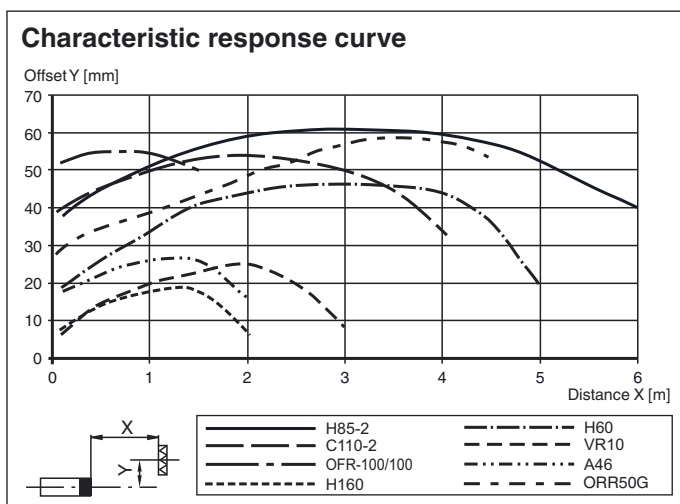

**Additional information**

**Instructions for the Teach-In mode:**

Step	Switch position	LED green	LED yellow	Time/Frequency	Explanations/Remarks
1	N	on	flashes	4/s	In switch position "N" aligned with reflector. Reflector detected <b>without functional reserve</b> .
	N	on	on	-	In switch position "N" aligned with reflector. Reflector detected <b>with functional reserve</b> (recommended).
2	T	off/on	on	200 ms	A new switch position is indicated by the green LED going out briefly. This applies also for the selection of the other switch positions.
	T	flashes	flashes	2.5/s	<i>Slow</i> alternating flashing: Teach-In process <b>correctly</b> executed. Max. duration of the Teach-In process: 2 s
	T	flashes	flashes	8/s	<i>Rapid</i> alternating flashing: Teach-In process <b>not correctly</b> executed. (e.g. receiver signal not sufficient, sensor not correctly aligned with reflector). Status is terminated by turning switch to position N.
3/1	I	on	on	-	Contrast detection 10 % is activated. (e.g. clean PET bottles filled with water)
3/2	II	on	on	-	Contrast detection 18 % is activated. (e.g. bottles made of clear glass)

Release date: 2013-06-18 15:39 Date of issue: 2013-06-18 183621\_eng.xml

3/3	III	on	on	-	Contrast detection 40 % is activated. (e.g. tinted glass or intransparent materials)
-----	-----	----	----	---	---

**Ext. TEACH input:**

In switch position "T" it is possible to trigger a Teach-In process and to select the corresponding contrast detection level by the external application of a High pulse of a certain width:

- I: 50 ms (30 ... 80 ms)
- II: 150 ms (120 ... 180 ms)
- III: 250 ms (220 ... 280 ms)
- N: 350 ms (320 ... 380 ms)