



**Model Number**

**VDM35-30-R/20/105/122**

Distance sensor  
with 5-pin, M12 x 1 connector

**Features**

- Can be aligned using an integrated pilot laser
- Adjustable switch outputs
- Not sensitive to ambient light
- Analog output 4 mA ... 20 mA

**Dimensions**

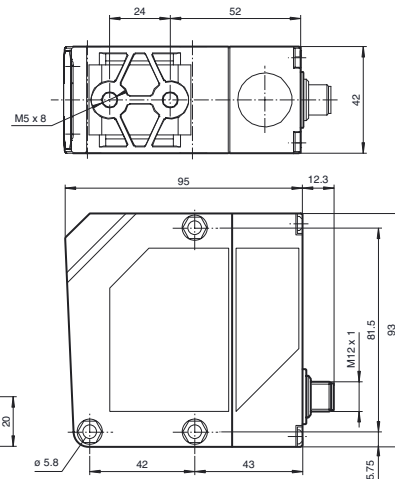

**Electrical connection**

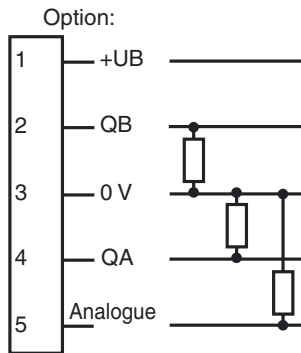

**Pinout**

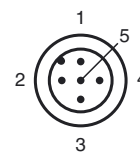

**Indicators/operating means**

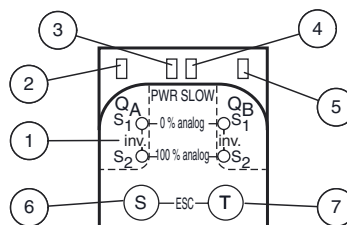

1	LED Menue	red
2	LED QA	yellow
3	LED Fast	orange
4	LED Power	green
5	LED QB	yellow
6	Button Set	
7	Button Toggle	

Release date: 2013-10-11 12:04 Date of issue: 2013-10-11 186465\_eng.xml

**Technical data****General specifications**

Measurement range	0.2 ... 30 m
Reference target	OFR-100/100
Light source	laser diode
Light type	modulated visible red light modulated infrared light
<b>Laser nominal ratings</b>	
Note	VISIBLE AND INVISIBLE LASER RADIATION , DO NOT STARE INTO BEAM
Laser class	Measurement laser: 1 Alignment laser: 2
Wave length	Measurement laser: 905 nm Alignment laser: 650 nm
Beam divergence	Measurement laser: 2 mrad Alignment laser: 1 mrad
Pulse length	Measurement laser: 6 ns Alignment laser: 0.25 $\mu$ s
Repetition rate	Measurement laser: 40 kHz Alignment laser: 1 kHz
Maximum optical power output	Measurement laser: 1.8 W Alignment laser: 3 mW
Measuring method	Time of flight measurement
Diameter of the light spot	45 mm x 60 mm at a distance of 30 m
Ambient light limit	5000 Lux
Temperature influence	analog typ. 0.1 %/K, switch output typ. 0.05 $\mu$ /K

**Indicators/operating means**

Operation indicator	LED green
Function indicator	LED yellow: switching state (2x) , LED orange : Operating mode
Control elements	Control panel : Adjuster for switch point , Operating mode , Analog output ( S - Set , T - Toggle )
Parameterization indicator	LED red (4x)

**Electrical specifications**

Operating voltage	$U_B$	18 ... 30 V DC , class 2
Ripple		10 % within the supply tolerance
No-load supply current	$I_0$	$\leq$ 125 mA / 24 V DC
Time delay before availability	$t_v$	$\leq$ 300 ms

**Output**

Switching type	light/dark on, switchable	
Signal output	2 PNP, short-circuit protected	
Switching current	max. 100 mA	
Measurement output	1 analog output 4 ... 20 mA, short-circuit/overload protected , $R_{max} = 500 \text{ Ohm}$	
Voltage drop	$U_d$	$\leq$ 2.4 V
Deviation of the characteristic curve		typ. $\leq \pm 60 \text{ mm}$
Switching frequency	$f$	Fast: 17 Hz / Slow: 8 Hz
Response time		Fast: 30 ms / Slow: 65 ms
Repeat accuracy	$R$	Fast: typ. $\leq \pm 10 \text{ mm}$ / Slow: typ. $\leq \pm 5 \text{ mm}$

**Ambient conditions**

Ambient temperature	-10 ... 50 °C (14 ... 122 °F)
Storage temperature	-40 ... 80 °C (-40 ... 176 °F)

**Mechanical specifications**

Protection degree	IP67
Connection	M12 x 1 connector, 5-pin
<b>Material</b>	
Housing	ABS
Optical face	PMMA
Mass	200 g

**Compliance with standards and directives**

<b>Directive conformity</b>	
EMC Directive 2004/108/EC	EN 60947-5-2
<b>Standard conformity</b>	
Laser class	IEC 60825-1:2001

**Approvals and certificates**

Approvals	CE, cULus
-----------	-----------

**Accessories****OMH-VDM35**

Mounting bracket

**OMH-VDM35-01**

Adjustment set series VDM35

**VDM35-AR**

Alignment aid for VDM35 and VDM70 series

Other suitable accessories can be found at [www.pepperl-fuchs.com](http://www.pepperl-fuchs.com)

**Curves/Diagrams**

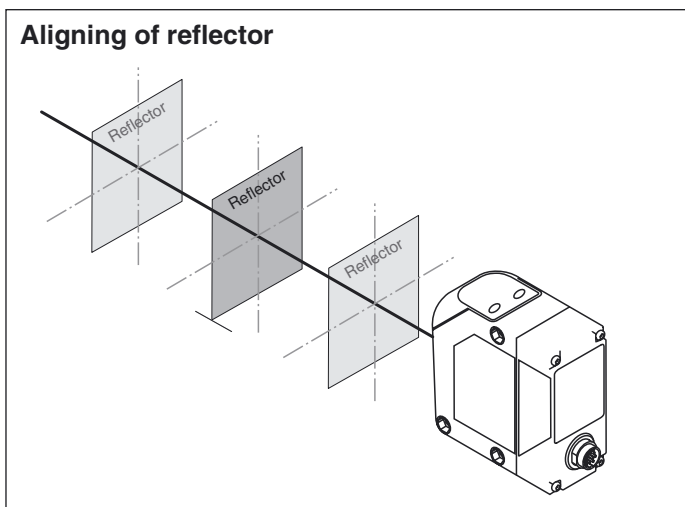
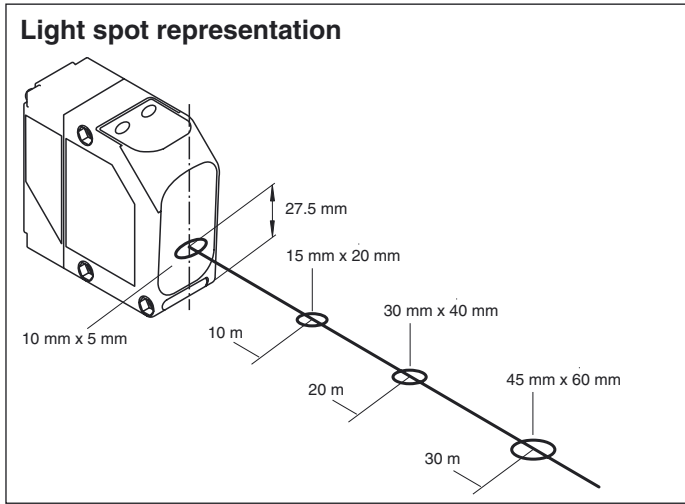

Release date: 2013-10-11 12:04 Date of issue: 2013-10-11 186465\_eng.xml

Refer to "General Notes Relating to Pepperl+Fuchs Product Information".

Pepperl+Fuchs Group  
www.pepperl-fuchs.com

USA: +1 330 486 0001  
fa-info@us.pepperl-fuchs.com

Germany: +49 621 776 4411  
fa-info@de.pepperl-fuchs.com

Singapore: +65 6779 9091  
fa-info@sg.pepperl-fuchs.com