

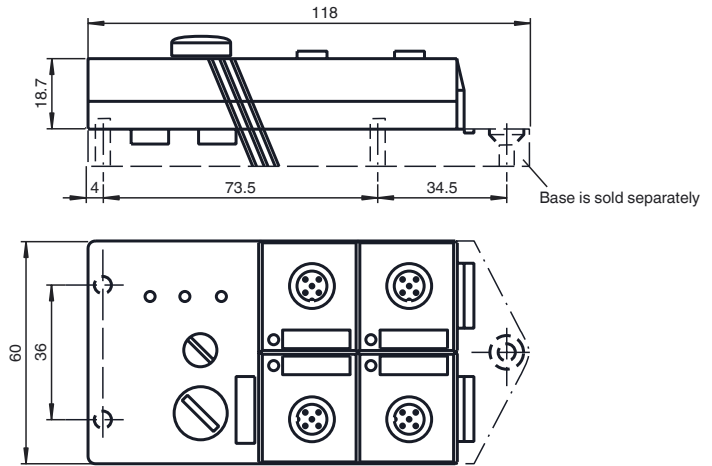

Dimensions

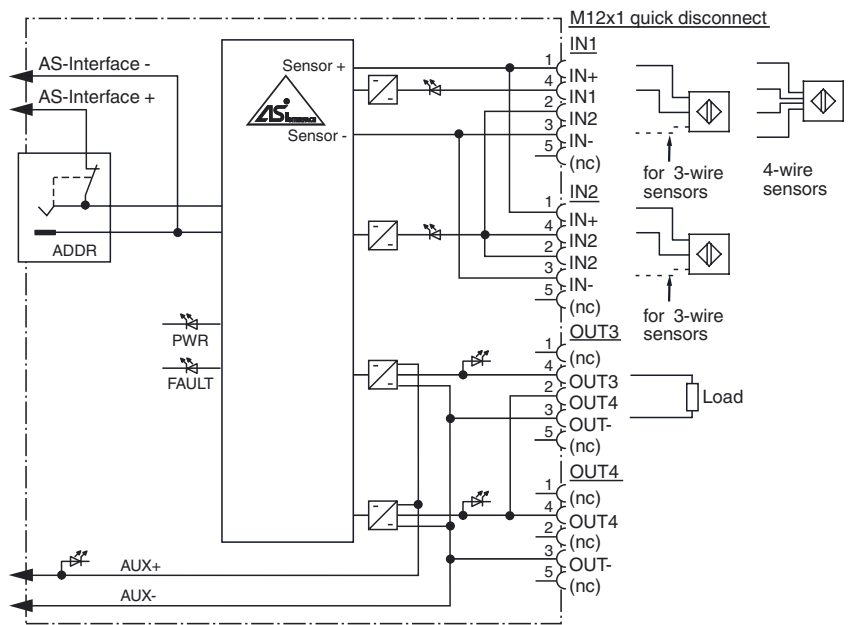

Electrical connection



Model number

VAA-2EA-G2-ZA/EA2

G2 flat module
2 inputs (PNP) and 2 electronic outputs

Features

- AS-Interface certificate
- Protection degree IP67
- Addressing jack
- Flat cable connection with cable piercing technique, variable flat cable guide
- Communication monitoring
- Inputs for 2- and 3-wire sensors
- Power supply of outputs from the external auxiliary voltage
- Power supply of inputs from the module
- Function display for bus, ext. auxiliary voltage, inputs and outputs
- Monitoring of sensor overloads

Indicating / Operating means

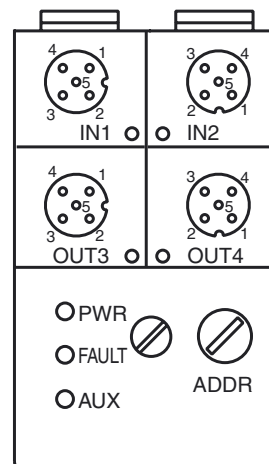

Release date: 2013-12-12 13:56 Date of issue: 2013-12-12 187747_eng.xml

Refer to "General Notes Relating to Pepperl+Fuchs Product Information".

Pepperl+Fuchs Group
www.pepperl-fuchs.com

USA: +1 330 486 0001
fa-info@us.pepperl-fuchs.com

Germany: +49 621 776 4411
fa-info@de.pepperl-fuchs.com

Singapore: +65 6779 9091
fa-info@sg.pepperl-fuchs.com

Technical data**General specifications**

Slave type	Standard slave
AS-Interface specification	V3.0
Required master specification	≥ V2.0
UL File Number	E87056

Indicators/operating means

LED FAULT	error display; LED red red: communication error or address is 0 red flashing: overload of sensor supply
LED PWR	AS-Interface voltage; LED green
LED AUX	ext. auxiliary voltage U_{AUX} ; LED green
LED IN	switching state (input); 2 LED yellow
LED OUT	Switching state (output); 2 LED yellow

Electrical specifications

Auxiliary voltage (output)	U_{AUX}	24 V DC ± 15 % PELV
Rated operating voltage	U_e	26.5 ... 31.6 V from AS-Interface
Rated operating current	I_e	≤ 40 mA (without sensors) / max. 190 mA
Protection class		III

Input

Number/Type	2 inputs for 2- or 3-wire sensors (PNP), DC
Supply	from AS-Interface
Voltage	21 ... 31 V
Current loading capacity	≤ 150 mA ($T_B \leq 40^\circ\text{C}$), ≤ 120 mA ($T_B \leq 60^\circ\text{C}$), short-circuit protected
Input current	≤ 8 mA (limited internally)
Switching point	according to DIN EN 61131-2 (Type 2)
0 (unattenuated)	≤ 1.5 mA
1 (attenuated)	≥ 4.5 mA
Signal delay	< 2 ms (input/AS-Interface)
Signal frequency	≤ 250 Hz

Output

Number/Type	2 electronic outputs, PNP
Supply	from external auxiliary voltage U_{AUX}
Current	1 A per output
Voltage	≥ ($U_{AUX} - 0.5\text{ V}$)

Programming instructions

Profile	S-3.F
IO code	3
ID code	F
ID1 code	F
ID2 code	F

Data bits (function via AS-Interface)	input	output
D0	IN1	-
D1	IN2	-
D2	-	OUT3
D3	-	OUT4

Parameter bits (programmable via AS-i)

Parameter bits	function
P0	Communication monitoring P0 = 0 monitoring = off, the outputs maintain the status if communication fails P0 = 1 monitoring = on, i.e. if communication fails, the outputs are deenergised (basic setting)
P1	Input filter P1 = 0 input filter on, pulse suppression ≤ 2 ms P1 = 1 input filter off (basic setting)
P2	Synchronous mode P2 = 0 synchronous mode on P2 = 1 synchronous mode off (basic setting)
P3	not used

Ambient conditions

Ambient temperature	-25 ... 60 °C (-13 ... 140 °F)
Storage temperature	-25 ... 85 °C (-13 ... 185 °F)

Mechanical specifications

Protection degree	IP67
Connection	Cable piercing method flat cable yellow/flat cable black inputs/outputs: M12 round connector
Material	
Housing	PBT
Mass	100 g
Mounting	Mounting base

Compliance with standards and directives

Directive conformity	
EMC Directive 2004/108/EC	EN 61000-6-2:2001, EN 61000-6-4:2001, EN 50295:1999
Standard conformity	

Function

The VAA-2EA-G2-ZA/EA2 is an AS-Interface coupling module with 2 inputs and 2 outputs. Mechanical contacts and 2- and 3-wire sensors can be connected to the inputs. The outputs are electronic outputs, which can be loaded to 24 V DC and 1 A per output.

The IP67 flat module features an integrated addressing jack and is ideal for applications in the field.

Connection to sensors/actuators is provided via M12 x 1 screw connections. The current switching state of each channel is indicated by an LED located on the module's top side. Similarly, an LED is provided to monitor the AS-Interface communication and to indicate that the module has the address 0. If an AS-Interface communication error occurs, the outputs are de-energised.

The input circuit is monitored for short circuits. LEDs are also provided to indicate AS-Interface voltage and external power supply.

The U-G3FF mounting base is normally used for the connection of the AS-Interface flat cable and the external 24 V DC power supply. The specially designed base enables the user to connect flat cables from both sides. This means, for example, that 90° curves can be laid with very tight radii (variable flat cable guide).

Note:

The mounting base for the module is sold separately.

Accessories**VBP-HH1-V3.0-KIT**

AS-Interface Handheld with accessory

VBP-HH1-V3.0

AS-Interface Handheld

VAZ-PK-1,5M-V1-G

Adapter cable module/hand-held programming device

VAZ-FK-ED-G2

AS-Interface end seal for G2 modules

Matching system components**U-G3FF**

AS-Interface module mounting base for connection to flat cable (AS-Interface and external auxiliary power)

Noise immunity	EN 61000-6-2:2001
Emitted interference	EN 61000-6-4:2001
Input	EN 61131-2:2007
Protection degree	EN 60529:2000
Fieldbus standard	EN 50295:1999, IEC 62026-2:2006

Notes

Do not connect inputs and outputs, which are supplied via the module from AS-interface or via auxiliary power, with power supply and signal circuits with external potentials.