

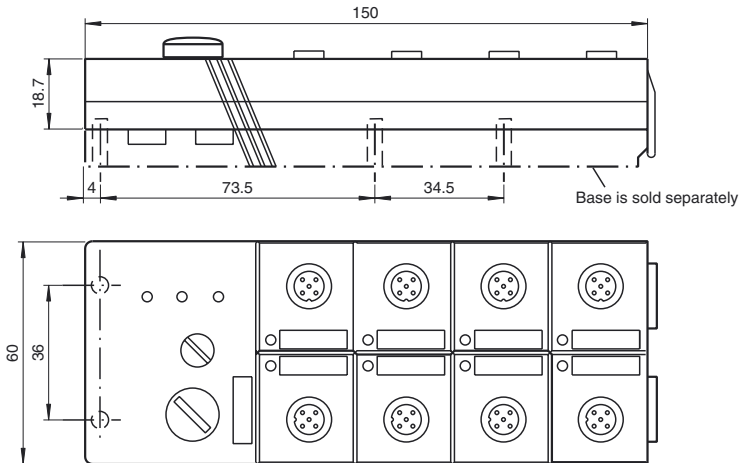

Dimensions

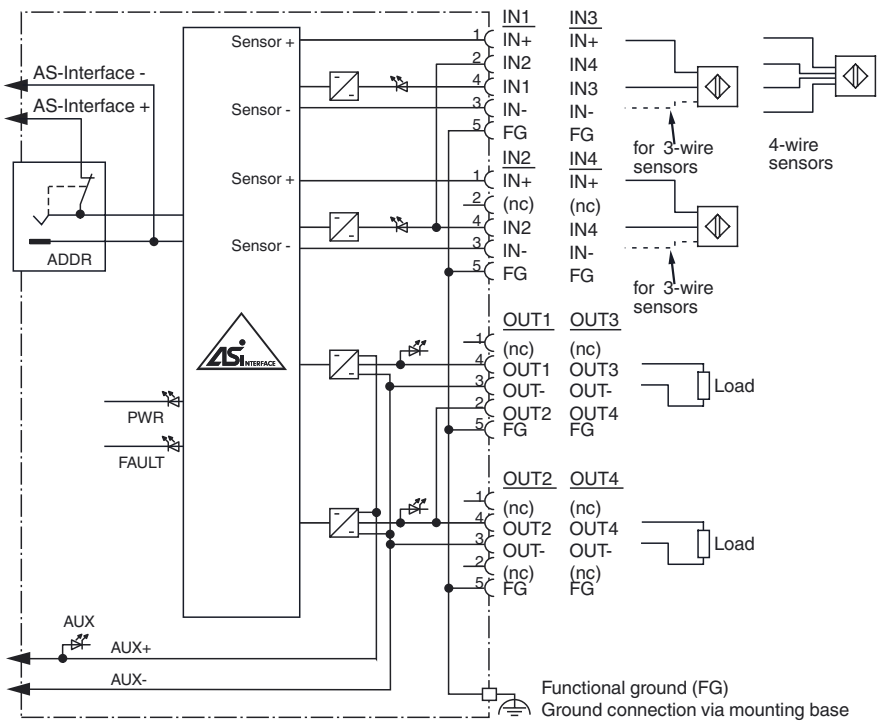

Electrical connection



Indicating / Operating means

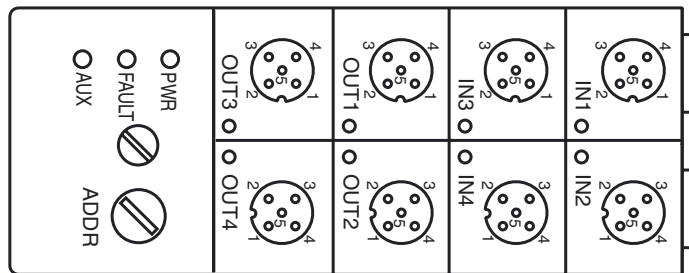

Model number

VAA-4E4A-G2-ZA/EA2

G2 flat module
4 inputs (PNP) and 4 electronic outputs

Features

- AS-Interface certificate
- Protection degree IP67
- Addressing jack
- Flat cable connection with cable piercing technique, variable flat cable guide
- Communication monitoring
- Inputs for 2-, 3-, and 4-wire sensors
- Power supply of outputs from the external auxiliary voltage
- Supply for inputs from AS-Interface
- Ground connection (FE) possible
- Function display for bus, ext. auxiliary voltage, inputs and outputs
- Detection of overload on sensor supply
- Detection of output overload

Release date: 2013-12-12 13:57 Date of issue: 2013-12-12 188848_eng.xml

Technical data**General specifications**

Slave type	Standard slave
AS-Interface specification	V3.0
Required master specification	≥ V2.0
UL File Number	E87056

Functional safety related parameters

MTTF _d	140 a
Mission Time (T _M)	20 a
Diagnostic Coverage (DC)	0 %

Indicators/operating means

LED FAULT	error display; LED red red: communication error or address is 0 red flashing: overload of sensor power supply or outputs
LED PWR	AS-Interface voltage; LED green
LED AUX	ext. auxiliary voltage U _{AUX} ; LED green
LED IN	switching state (input); 4 LED yellow
LED OUT	Switching state (output); 4 LED yellow

Electrical specifications

Auxiliary voltage (output)	U _{AUX}	20 ... 30 V DC PELV
Rated operating voltage	U _e	26.5 ... 31.6 V from AS-Interface
Rated operating current	I _e	≤ 40 mA (without sensors) / max. 220 mA
Protection class		III

Input

Number/Type	4 inputs for 2- or 3-wire sensors (PNP), DC option 2 inputs for 4-wire sensors (PNP), DC
Supply	from AS-Interface
Voltage	21 ... 31 V
Current loading capacity	≤ 180 mA (T _B ≤ 40 °C), ≤ 140 mA (T _B ≤ 60 °C), , overload and short-circuit protected
Input current	≤ 9 mA (limited internally)
Switching point	according to DIN EN 61131-2 (Type 2)
0 (unattenuated)	≤ 3 mA
1 (attenuated)	≥ 5 mA
Signal delay	< 2 ms (input/AS-Interface)
Signal frequency	≤ 250 Hz

Output

Number/Type	4 electronic outputs, PNP, overload and short-circuit proof
Supply	from external auxiliary voltage U _{AUX}
Current	2 A per output Sum 4 A (T _B ≤ 40 °C) Sum 3 A (T _B ≤ 60 °C)
Voltage	≥ (U _{AUX} - 0.5 V)

Programming instructions

Profile	S-7.F
IO code	7
ID code	F
ID1 code	F
ID2 code	E

Data bits (function via AS-Interface)	input	output
D0	IN1	OUT1
D1	IN2	OUT2
D2	IN3	OUT3
D3	IN4	OUT4

Parameter bits (programmable via AS-i)

Parameter	function
P0	communication monitoring P0 = 1 (basic setting), monitoring = ON, i.e. if communication fails, the outputs are de-energised P0 = 0, monitoring = OFF, if communication fails, the outputs maintain their condition
P1	not used
P2	not used
P3	not used

Ambient conditions

Ambient temperature	-25 ... 60 °C (-13 ... 140 °F)
Storage temperature	-25 ... 85 °C (-13 ... 185 °F)

Mechanical specifications

Protection degree	IP67
Connection	Cable piercing method flat cable yellow/flat cable black inputs/outputs: M12 round connector
Material	
Housing	PBT
Mass	150 g
Mounting	Mounting base

Compliance with standards and directives**Function**

The VAA-4E4A-G2-ZA/EA2 is an AS-Interface module with 4 Inputs and 4 outputs. Mechanical contacts (e. g. push buttons) as well as 2-, 3- and 4-wire sensors can be connected to the inputs. The outputs are electronic outputs, which can be collectively loaded with 24 V DC and 1 A per output.

The IP67 flat module is ideal for applications in the field. An addressing jack is integrated in the module.

The connection for the sensors/actuators is via M12 x 1 screw connections. An LED is provided on the top of the module, for each channel, to indicate the current switching status. Similarly, an LED is provided to monitor the AS-Interface communication and to indicate that the module has the address 0. LEDs are also provided to indicate AS-Interface voltage and external power supply.

The mounting plate U-G2FF is used as standard for the connection to the AS-Interface flat cable and the external 24 V DC supply. The specially designed base enables the user to connect flat cable from both sides.

The device incorporates communication monitoring, which switches off power to the outputs if no communication has taken place on the AS-Interface line for longer than 40 ms.

An overloading of the internal input supply or of the outputs is signalled to the AS-interface master via the "Peripheral fault" function. Communication via the AS-Interface remains intact.

Note:

The mounting base for the module is sold separately.

Accessories**VBP-HH1-V3.0-KIT**

AS-Interface Handheld with accessory

VBP-HH1-V3.0

AS-Interface Handheld

VAZ-PK-1,5M-V1-G

Adapter cable module/hand-held programming device

VAZ-FK-ED-G2

AS-Interface end seal for G2 modules

Matching system components**U-G2FF**

AS-Interface module mounting base for connection to flat cable (AS-Interface and external auxiliary power)

Directive conformity		
EMC Directive 2004/108/EC		EN 61000-6-2:2001, EN 61000-6-4:2001, EN 50295:1999
Standard conformity		
Noise immunity		EN 61000-6-2:2001
Emitted interference		EN 61000-6-4:2001
Input		EN 61131-2:2007
Protection degree		EN 60529:2000
Fieldbus standard		EN 50295:1999, IEC 62026-2:2006

Notes

For 4-wire sensors, it is only possible to use plug-in slot IN1 or IN3 for inputs 1+2 or 3+4 (jumped internally).

Do not connect inputs and outputs, which are supplied via the module from AS-interface or via auxiliary power, with power supply and signal circuits with external potentials.