



## Model number

**K23-SSI/R2/25B-C**

Signal converter SSI/RS 232/Parallel

## Features

- Suitable for the connection of sensors and absolute encoders with SSI interface
- Converts both SSI data and serial data into a parallel format
- Parallel output 25 bit (Push-pull, short-circuit proof)
- RS 232 Interface for the serial read out of sensor information
- SSI: Master or slave operation
- Specified option for arbitrary linearisation characteristics
- Additional functions such as z. B. bit masking, concentricity function
- Supply 18 V DC ... 30 V DC

## Technical data

### Electrical specifications

Rated operational voltage $U_e$	18 ... 30 V DC
Rated operational current $I_e$	$\leq 200$ mA

### Input 1

Input type	SSI
Input format	Gray code, binary code
Resolution	13, 21 or 25 bit
Input frequency	100 Hz ... 1 MHz

### Input 2

Input type	HTL (Hold)
Signal voltage	
High	$\geq 10$ V
Low	$\leq 3$ V
Internal resistor	5 k $\Omega$

### Output

Number/Type	Parallel
Output format	Gray-Code, Binary-Code, BCD-Code
Contact loading	max. 35 V on COM+ (Short-circuit resistance up to 27 V) max. 1.2 kA $\pm 10$ % at 24 V ( $R_i = 600 \Omega$ )

### Ambient conditions

Ambient temperature	0 ... 45 °C (273 ... 318 K)
---------------------	-----------------------------

### Mechanical specifications

Connection	screw terminals , max. core cross-section 0.34 ... 2.5 mm <sup>2</sup>
Mass	approx. 190 g

## Function

K23-SSI/R2/25B-C represents a small and low-cost, but highly performant converter for industrial applications, where the information of a sensor or encoder with SSI interface needs to be converted to a parallel signal or a serial RS 232 data format. Also it is possible to convert serial RS 232 data to a parallel format. The unit has been designed as a compact module with 12 screw terminals, a 9-pin and a 25-pin Sub-D connector (female). The housing is suitable for standard DIN rail mounting.

### Applicable encoders and sensors

Single-turn or multi-turn absolute encoders and all similar sensors using a standard SSI interface (6 .. 25 bits of resolution with binary or Gray code). The unit can operate in either master mode (clock signal generated by the unit), or in slave mode (clock signal generated by a remote device).

### Remark about the encoder resolution

The unit provides settings for the standard resolutions of 13 bits, 21 bits and 25 bits. In general, for sensors with other resolutions you can use the next higher setting (i. e. set the unit to 21 bits with a sensor of 16 bits). Depending on brand and specification of the encoder, in some cases it may be necessary to blank out the surplus bits by using the bit blanking function described later. In general however, the unit should work perfectly also without special bit blanking.

Dimensions

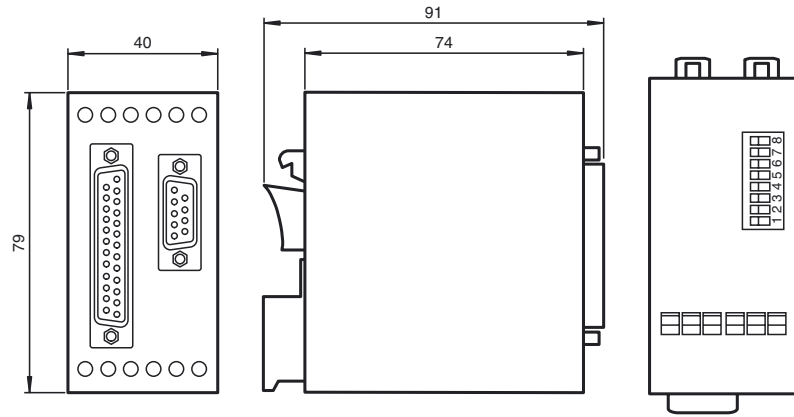

Indicating / operating

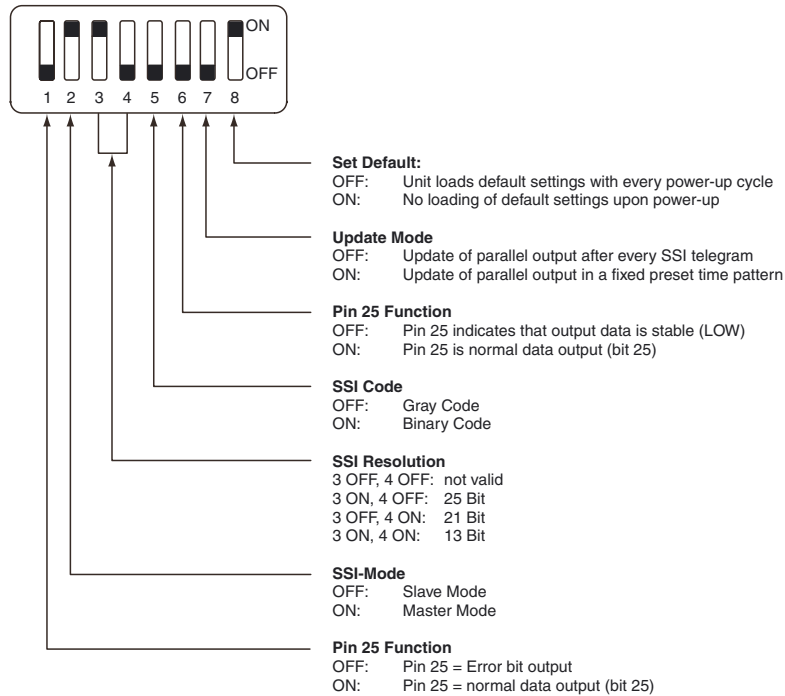

Electrical connection

