

Dimensions

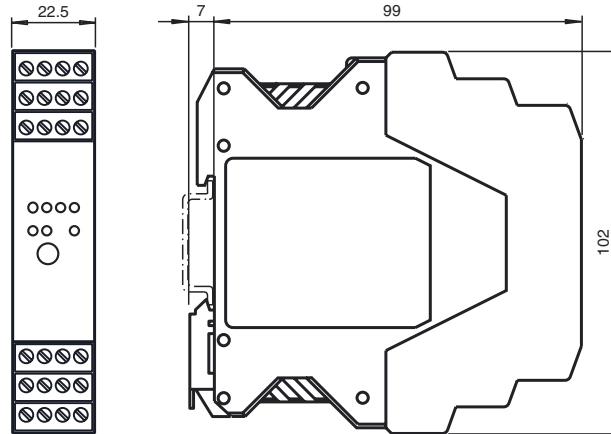

Electrical connection

Model Number

VAA-4E-KE-ZE

KE switch cabinet module  
4 inputs (PNP)

Features

- Housing with removable, coded terminals
- Communication monitoring
- Inputs for 2- and 3-wire sensors
- Addressing jack
- Selectable supply to the sensors: External or from the module
- Function display for bus, internal sensor supply and inputs

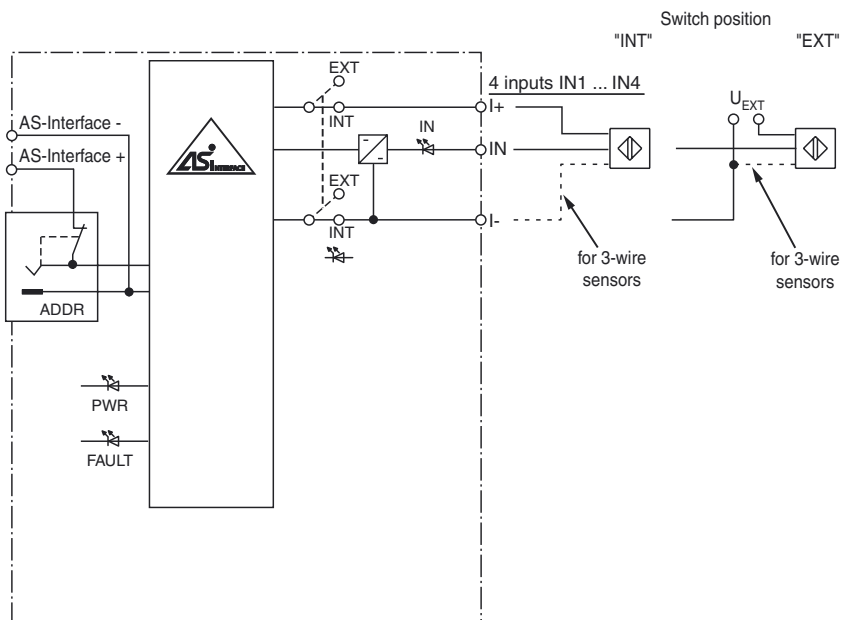

Indicators / Operating means

ATTENTION

Do not connect the terminals I+, IN and I- with any external potential when switch set to "INT"

Sensor supply:  
INT = internal sensor supply (from AS-i)  
EXT = external sensor supply

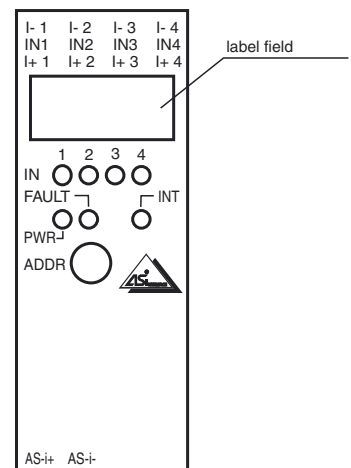
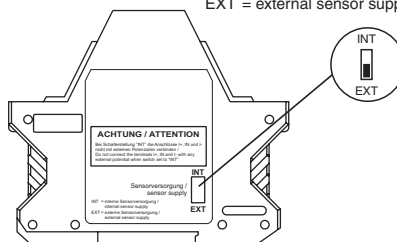

Release date: 2009-08-27 16:04 Date of issue: 2009-09-28 191666\_ENG.xml

**Technical data****General specifications**

Slave type	Standard slave
AS-Interface specification	V2.1
Required master specification	≥ V2.0
UL File Number	E87056

**Functional safety related parameters**

MTTF <sub>d</sub>	620 a
Mission Time (T <sub>M</sub> )	20 a
Diagnostic Coverage (DC)	0 %

**Indicators/operating means**

LED FAULT	Fault display; Red LED red: Communication fault or address is 0 red, flashing: Overload, internal input supply
LED INT	Internal input voltage active; LED green
LED PWR	AS-Interface voltage; LED green
LED IN	switching state (input); 4 LED yellow

**Electrical specifications**

Auxiliary voltage (input)	U <sub>EXT</sub>	12 ... 30 V DC PELV
Protection class		III
Rated operational voltage	U <sub>e</sub>	26.5 ... 31.6 V from AS-Interface
Rated operational current	I <sub>e</sub>	≤ 35 mA (without sensors) / max. 190 mA
Overvoltage protection		U <sub>EXT</sub> , U <sub>e</sub> : Over voltage category III, safe isolated power supplies (PELV)

**Input**

Number/Type	4 inputs for 2- or 3-wire sensors (PNP), DC
Supply	from AS-Interface (switch position INT, basic setting) or external U <sub>EXT</sub> (switch position EXT)
Voltage	21 ... 31 V DC (INT)
Current loading capacity	≤ 150 mA, overload- and short-circuit proof (INT)
Input current	≤ 8 mA (limited internally)
Switching point	according to DIN EN 61131-2 (Type 2)
0 (unattenuated)	≤ 2 mA
1 (attenuated)	≥ 4 mA
Signal delay	< 2 ms (input/AS-Interface)
Signal frequency	≤ 250 Hz

**Programming instructions**

Profile	S-0.0
IO code	0
ID code	0
ID1 code	F
ID2 code	0

**Data bits (function via AS-Interface)**

	Input
D0	IN1
D1	IN2
D2	IN3
D3	IN4

**Parameter bits (programmable via AS-i)**

Parameter	function
P0	not used
P1	not used
P2	not used
P3	not used

**Ambient conditions**

Ambient temperature	-25 ... 60 °C (248 ... 333 K)
Storage temperature	-25 ... 85 °C (248 ... 358 K)
Relative humidity	90 % , non-condensing
Pollution Degree	2

**Mechanical specifications**

Protection degree	IP20
Connection	removable terminals rated connection capacity: rigid/flexible (with and without wire-end ferrules): 0.25 mm <sup>2</sup> ... 2.5 mm <sup>2</sup> for multiple-wire connection with two wires of equal cross-section: flexible with twin wire-end ferrules: 0.5 mm <sup>2</sup> ... 1.5 mm <sup>2</sup>
Material	
Housing	PA 66-FR
Mass	150 g
Mounting	DIN rail

**Compliance with standards and directives**

Directive conformity	
EMC Directive 2004/108/EC	EN 61000-6-2: 2005, EN 61000-6-4: 2007 , EN 50295:1999-10
Standard conformity	
Interference rejection	EN 61000-6-2:2005

**Function**

The VAA-4E-KE-ZE AS-Interface I/O module is a cabinet module with 4 inputs. The only 22.5 mm width housing requires not much space in the switch cabinet. The module is installed by snapping on the 35 mm DIN Rail in accordance with EN 50022.

The connection is made through plug-in terminals. For the inputs 4-way terminal blocks (black) are used. The connection of AS-Interface is made through the 2-way-terminal blocks. In order to avoid exchanges, the terminals for inputs are coded mechanically.

The power supply of the inputs and the connected sensors can be made as required via the internal supply of the module (AS-Interface) or via an external voltage source. The switching is carried out by means of a switch that is positioned at the side of the module. The selection of the internal input supply is indicated via the LED INT. The current switching state of each input is indicated by the resp. LED IN.

**Note:**

An overloading of the internal input supply will be reported via the function 'peripheral error' to the AS-Interface master. The communication via the AS-Interface remains intact.

**Accessories****VBP-HH1-V3.0**

AS-Interface Handheld

**VAZ-PK-1,5M-V1-G**

Connection cable module/hand-held programming device

Emitted interference	EN 61000-6-4:2007
AS-Interface	EN 50295:1999-10
Input	EN 61131-2: 2004
Protection degree	EN 60529:2000

### Notes

Do not connect inputs and outputs, which are supplied via the module from AS-interface or via auxiliary power, with power supply and signal circuits with external potentials.