



Model Number

PR32-030-P-2-F-S

Light grid
connector V37 (M9 x 0.5), 7-pin

Features

- High-resolution light grid
- Detects transparent materials
- Detecting any object shapes
- 32 parallel light beams
- Resolution 1.5 mm (0.059 in)

Dimensions

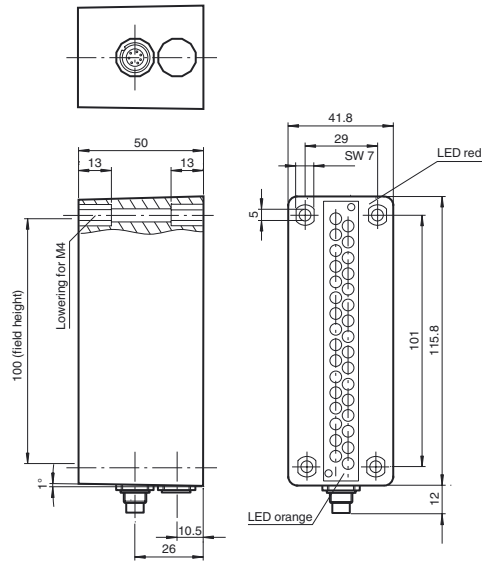

Electrical connection

Connector version

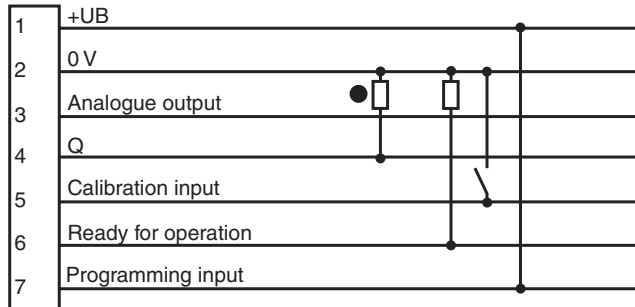

Release date: 2015-05-07 09:14 Date of issue: 2015-05-07 197600_eng.xml

Refer to "General Notes Relating to Pepperl+Fuchs Product Information".

Pepperl+Fuchs Group
www.pepperl-fuchs.com

USA: +1 330 486 0001
fa-info@us.pepperl-fuchs.com

Germany: +49 621 776 4411
fa-info@de.pepperl-fuchs.com

Singapore: +65 6779 9091
fa-info@sg.pepperl-fuchs.com

Technical data**General specifications**

| | |
|---------------------------|--------------------------|
| Effective detection range | 0 ... 500 mm |
| Threshold detection range | 500 mm |
| Sensing range | 0 ... 500 mm |
| Light source | IRED |
| Light type | modulated infrared light |
| Field height | 100 mm |
| Target size | 1.5 mm |
| Beam spacing | 3.2 mm |
| Number of beams | 32 |
| Ambient light limit | 20000 Lux |
| Resolution | 1.5 mm , Parallel |

Indicators/operating means

| | |
|--------------------|--|
| Function indicator | LED yellow, functional readiness, LED red, switching state, lights up when the beam field is interrupted |
|--------------------|--|

Electrical specifications

| | | |
|-------------------|-------|----------------|
| Operating voltage | U_B | 24 ... 28 V DC |
| Ripple | | 5 % |

Input

| | |
|----------------|--|
| Function input | Calibration input > 10 ms, ground active, fixed saving the switching threshold |
|----------------|--|

Output

| | | |
|---------------------|---|-------|
| Switching type | dark on | |
| Signal output | 1 PNP output, short-circuit protected, reverse polarity protected, open collector | |
| Switching voltage | max. 28 V DC | |
| Switching current | 100 mA | |
| Measurement output | 4 ... 20 mA | |
| Switching frequency | f | 20 Hz |
| Response time | 4 ms | |

Standard conformity

| | |
|-----------|--------------|
| Standards | EN 60947-5-2 |
|-----------|--------------|

Ambient conditions

| | |
|---------------------|-------------------------------|
| Ambient temperature | -10 ... 50 °C (14 ... 122 °F) |
| Storage temperature | -20 ... 70 °C (-4 ... 158 °F) |

Mechanical specifications

| | |
|----------------------|----------------------------------|
| Degree of protection | IP65 |
| Connection | connector V37 (M9 x 0.5), 7-pin |
| Material | |
| Housing | ABS |
| Optical face | PMMA |
| Mass | Emitter: 150 g , Receiver: 180 g |

Approvals and certificates

| | |
|-----------|----|
| Approvals | CE |
|-----------|----|

Additional Information**Functional description**

The device is a single path light grid, i.e. the transmitter and the receiver are located in separate housings.

The receiver housing contains an orange LED to signal operating readiness and a red LED to signal the status.

The red LED lights when the light grid is interrupted.

Calibration

During the calibration process, the orange and red LED are switched off.

- DURING THIS TIME ENSURE THAT NO OBJECT ENTERS THE PROTECTED AREA!

Otherwise unwanted transmitter and receiver characteristics will be included in the calibration.

- THE DISTANCE BETWEEN THE TRANSMITTER AND THE RECEIVER MUST NO LONGER BE CHANGED AFTER THE CALIBRATION!

After calibration, the orange LED lights permanently.

Under normal conditions, the red LED lights in the case of a new installation. That is, the old calibration values first have to be overwritten by a new CAL command before commissioning.

It is recommended to carry out a calibration on a daily basis.

Factory settings

1. Calibration version [F]

Calibration is only carried out by a command via the orange CAL connecting cable (= fixed in memory). These calibration values are retained even when the light grid is switched off and are available again after the device is switched on. It is recommended to carry out a calibration on a daily basis.

2. Sensitivity [2]

Suitable for highly transparent foils.

3. Beam evaluation [P]

The beams are evaluated in parallel [P].

General tips

The brown connecting cable is used for programming and must be used for normal operation at an operating voltage of +24 VDC.

Current is output at the analog output (blue cable strand). The analog output must be connected via a resistor (0 - 400 Ohm) to ground (GND).

If several light grids are installed, it must be ensured that a receiver only receives the light beams from its cooperating emitter.

Any light beam reflections must be excluded. The devices may only be installed and put into operation by qualified personnel.

It is essential that the electrical and mechanical limit values are adhered to in accordance with data sheet to ensure that the device works properly. The device may be destroyed if operated beyond these limits. Any warranty claim is void in the case of such damage.