

Features

- 1-channel signal conditioner
- 24 V DC supply (Power Rail)
- Thermocouple, RTD, voltage or current input
- 2 relay contact outputs
- Programmable high/low alarm
- Configurable by **PACTware**
- Sensor breakage detection

Function

This signal conditioner provides the galvanic isolation between field circuits and control circuits.

The device accepts a variety of inputs including RTDs or thermocouples. The device provides a relay trip whenever it reaches a userprogrammed set point.

The removable terminal block K-CJC-** is available as an accessory for internal cold junction compensation of thermocouples.

A fault is indicated by LEDs acc. to NAMUR NE44 and by user-configured fault indication outputs.

The device is easily configured by the use of the PACTware configuration software.

For additional information, refer to the manual and www.pepperl-fuchs.com.

Assembly

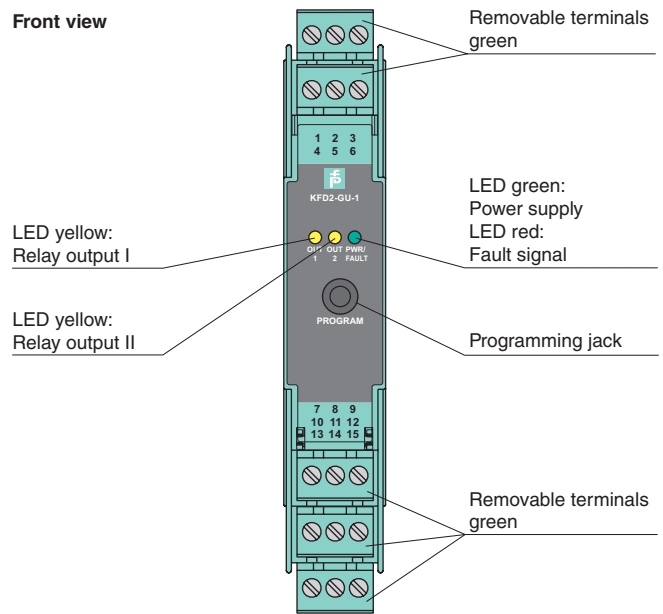

Connection

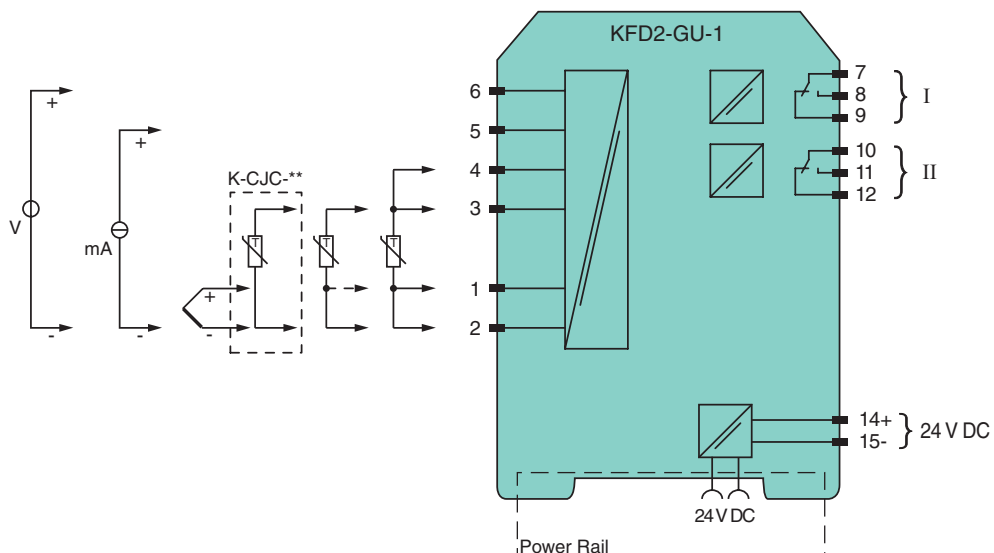

Release date 2014-04-30 14:07 Date of issue 2015-02-16 198403_eng.xml

Refer to "General Notes Relating to Pepperl+Fuchs Product Information".

Pepperl+Fuchs Group
www.pepperl-fuchs.com

USA: +1 330 486 0002
pa-info@us.pepperl-fuchs.com

Germany: +49 621 776 2222
pa-info@de.pepperl-fuchs.com

Singapore: +65 6779 9091
pa-info@sg.pepperl-fuchs.com

General specifications	
Signal type	Analog input
Supply	
Connection	Power Rail or terminals 14+, 15-
Rated voltage	U_n 19 ... 35 V DC
Ripple	within the supply tolerance
Power loss	0.8 W
Power consumption	0.8 W
Input	
Connection	terminals 1, 2, 3, 4, 5, 6
RTD or resistance	type Pt100 (EN 60751: 1995) type Ni100 (DIN 43760) 0 ... 500 Ω (including lead resistance)
Measuring current	approx. 400 μ A with RTD
Lead resistance	\leq 50 Ω per lead
Thermocouples	type B, E, J, K, N, R, S, T (IEC 584-1: 1995) type L (DIN 43710: 1985)
Voltage	0 ... 10 V, 2 ... 10 V
Current	0 ... 20 mA, 4 ... 20 mA
Load	20 Ω for 20 mA; 200 k Ω for 10 V
Output	
Connection	output I: terminals 7, 8, 9; output II: terminals 10, 11, 12
Output I, II	relay
Contact loading	253 V AC/2 A/500 VA/cos ϕ min. 0.7; 40 V DC/2 A resistive load
Mechanical life	2×10^7 switching cycles
Transfer characteristics	
Resolution	temperature: 0.0625 $^{\circ}$ C, resistance: 62.5 m Ω , voltage: 62.5 μ V, current: 625 nA
Deviation	
Voltage input	\pm 0.02 % of 10 V measuring range
Resistance input	\pm 0.025 % of measuring range (4-wire connection)
Current input	\pm 0.02 % of 20 mA measuring range
<u>Pt100</u>	\pm 0.01 % of abs. temperature value of switching point in K + 0.2 K (4-wire connection)
<u>Thermocouple</u>	\pm 0.05 % of abs. temperature value of switching point in K + 1.1 K (1.2 K for thermocouple types R and S) this includes \pm 0.8 K error of the cold junction compensation (+0.9 K for thermocouple types R and S). Note! Because the sensitivity of thermocouples is, in general, lower at low temperatures than at high temperatures, the specified accuracy figures cannot be guaranteed when measuring temperatures below those listed here. -50 $^{\circ}$ C (type E and K thermocouples) -100 $^{\circ}$ C (type J, L and T thermocouples) +500 $^{\circ}$ C (type B thermocouple)
Influence of ambient temperature	
<u>Pt100</u>	\pm (0.0015 % of abs. temperature value of switching point in K + 0.01 K)/K ΔT_{amb}^*)
<u>Thermocouple</u>	\pm (0.004 % of abs. temperature value of switching point in K + 0.01 K) / K ΔT_{amb}^*)
Voltage input	\pm (0.007 % of the switching point voltage) / K ΔT_{amb}^*)
Current input	\pm (0.004 % of the switching point current)/K ΔT_{amb}^*) ^{*)} ΔT_{amb} = ambient temperature change referenced to 23 $^{\circ}$ C (296 K)
Influence of supply voltage	$<$ 0.001 % of sensor input range
Input delay	\leq 370 ms (rise time and energizing delay of relay)
Electrical isolation	
Input/Output	reinforced insulation according to IEC/EN 61010-1, rated insulation voltage 300 V _{eff}
Input/power supply	basic insulation according to IEC/EN 61010-1, rated insulation voltage 300 V _{eff}
Output/power supply	reinforced insulation according to IEC/EN 61010-1, rated insulation voltage 300 V _{eff}
Output I/II	reinforced insulation according to IEC/EN 61010-1, rated insulation voltage 300 V _{eff}
Power supply/programming input	no electrical isolation
Directive conformity	
Electromagnetic compatibility	
Directive 2004/108/EC	EN 61326-1:2006
Low voltage	
Directive 2006/95/EC	EN 61010-1:2010
Conformity	
Electromagnetic compatibility	NE 21:2006
Degree of protection	IEC 60529:2001
Ambient conditions	
Ambient temperature	-20 ... 60 $^{\circ}$ C (-4 ... 140 $^{\circ}$ F)
Mechanical specifications	

Release date 2014-04-30 14:07 Date of issue 2015-02-16 198403_eng.xml

Refer to "General Notes Relating to Pepperl+Fuchs Product Information".

Degree of protection	IP20
Mass	approx. 150 g
Dimensions	20 x 119 x 115 mm (0.8 x 4.7 x 4.5 in) , housing type B2
Mounting	on 35 mm DIN mounting rail acc. to EN 60715:2001
General information	
Supplementary information	Statement of Conformity, Declaration of Conformity, Attestation of Conformity and instructions have to be observed where applicable. For information see www.pepperl-fuchs.com .

Accessories

Power feed module KFD2-EB2

The power feed module is used to supply the devices with 24 V DC via the Power Rail. The fuse-protected power feed module can supply up to 150 individual devices depending on the power consumption of the devices. A galvanically isolated mechanical contact uses the Power Rail to transmit collective error messages.

Power Rail UPR-03

The Power Rail UPR-03 is a complete unit consisting of the electrical inset and an aluminium profile rail 35 mm x 15 mm. To make electrical contact, the devices are simply engaged.

Profile Rail K-DUCT with Power Rail

The profile rail K-DUCT is an aluminum profile rail with Power Rail insert and two integral cable ducts for system and field cables. Due to this assembly no additional cable guides are necessary.



Power Rail and Profile Rail must not be fed via the device terminals of the individual devices!

K-CJC-**

This removable terminal block with integrated temperature measurement sensor is needed for internal cold junction compensation for thermocouples. One K-CJC-** is needed for each channel.

PACT^{ware}™

Device-specific drivers (DTM)

Adapter K-ADP-USB

Programming adapter for parameterisation via the serial USB interface of a PC/Notebook