



Model Number

GA18/GK18/59/115/161

Thru-beam sensor
with 2 m fixed cable

Features

- Efficient Line in a short M18 plastic housing for standard applications
- Very high detection range
- 4 LEDs indicator for 360° visibility
- Version with front optical face
- Universal usage at different power supplies

Product information

The GLV/GLK18 series sensors help improve the efficiency of machines and systems. The design of the M18 plastic housing, the connection technology, and sensor properties are highly standardized. Concentrating on the key sensor requirements has produced a robust and reliable product series for DC and AC/DC voltage systems without any over-engineering. The mounting set included in the scope of delivery and the optimized potentiometer design ensure fast assembly and easy configuration.

Dimensions

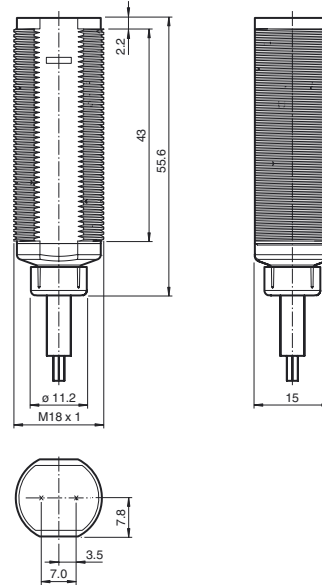

Electrical connection

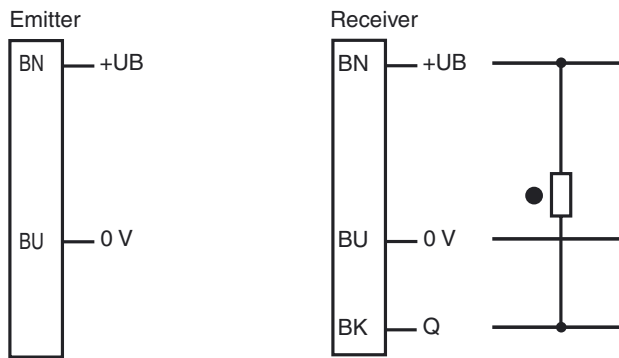

- = Light on
- = Dark on

Indicators/operating means

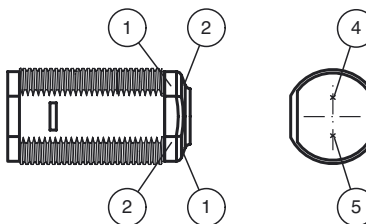

1	Operating display	green
2	Signal display	yellow
4	Emitter	
5	Receiver	

Release date: 2015-02-06 08:39 Date of issue: 2015-02-06 199777_eng.xml

Technical data

System components

Emitter	GA18/115
Receiver	GK18/59/115/161

General specifications

Effective detection range	0 ... 20 m
Threshold detection range	25 m
Light source	LED
Light type	modulated visible red light , 640 nm
Diameter of the light spot	approx. 1000 mm at 25 m
Angle of divergence	approx. 3 °
Optical face	frontal
Ambient light limit	30000 Lux
Accessories provided	Mounting aids

Indicators/operating means

Operation indicator	LED green, statically lit Power on
Function indicator	Receiver: LED yellow, lights up when light beam is free, flashes when falling short of the stability control ; OFF when light beam is interrupted

Electrical specifications

Operating voltage	U_B	20 ... 250 V AC/DC
No-load supply current	I_0	< 2.5 mA per device

Output

Switching type	dark on	
Signal output	N-channel MOSFET, short circuit protected	
Switching voltage	max. 250 V AC/DC	
Switching current	max. 200 mA	
Voltage drop	U_d	≤ 3.5 V AC/DC
Switching frequency	f	50 Hz
Response time		≤ 10 ms

Ambient conditions

Ambient temperature	-20 ... 60 °C (-4 ... 140 °F)
Storage temperature	-40 ... 70 °C (-40 ... 158 °F)

Mechanical specifications

Degree of protection	IP67
Connection	2 m fixed cable
Material	
Housing	ABS / PBT
Optical face	PMMA
Mass	approx. 80 g per device

Compliance with standards and directives

Standard conformity	
Product standard	EN 60947-5-2:2007 ; IEC 60947-5-2:2007
Standards	UL 508

Approvals and certificates

Protection class	II, rated insulation voltage ≤ 250 V AC with pollution degree 1-2 according to IEC 60664-1
UL approval	cULus Listed, Type 1 enclosure
CCC approval	Certified by China Compulsory Certification (CCC)

Curves/Diagrams

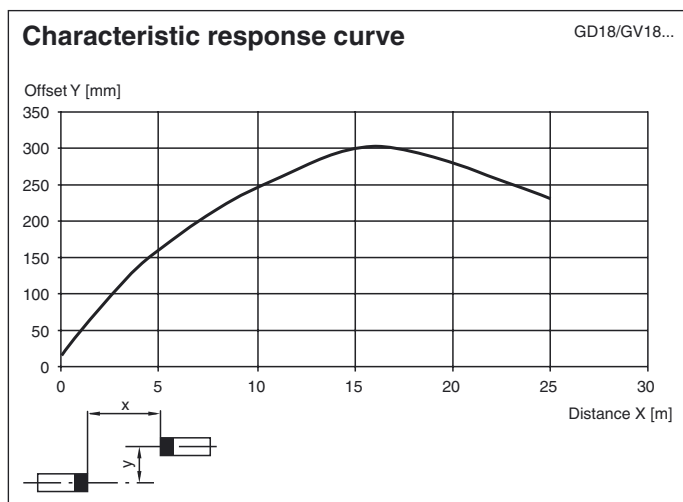

Accessories

CPZ18B03

Mounting Bracket with swivel nut

BF 18

Mounting flange, 18 mm

BF 18-F

Mounting flange with dead stop, 18 mm

BF 5-30

Universal mounting bracket for cylindrical sensors with a diameter of 5 ... 30 mm

Other suitable accessories can be found at www.pepperl-fuchs.com

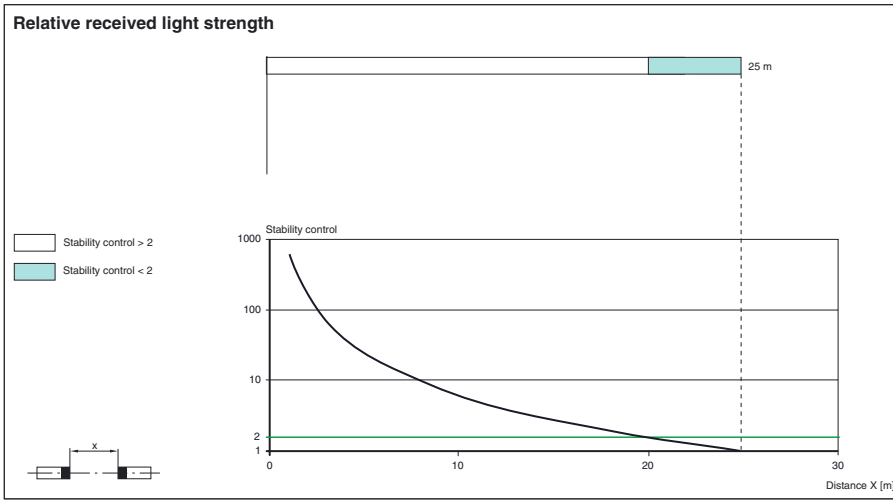

Release date: 2015-02-06 08:39 Date of issue: 2015-02-06 199777_eng.xml

Refer to "General Notes Relating to Pepperl+Fuchs Product Information".

Pepperl+Fuchs Group
www.pepperl-fuchs.com

USA: +1 330 486 0001
fa-info@us.pepperl-fuchs.com

Germany: +49 621 776 4411
fa-info@de.pepperl-fuchs.com

Singapore: +65 6779 9091
fa-info@sg.pepperl-fuchs.com