

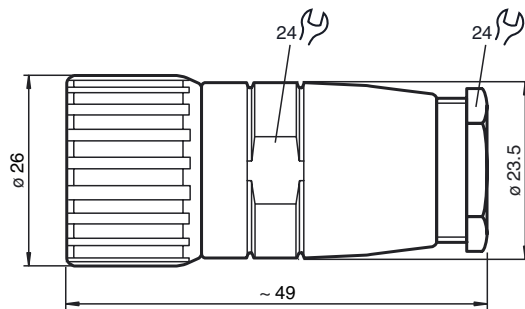

Dimensions



Model Number

V23-19-G

Female cordset, field attachable

Technical data

General specifications

Number of pins 16+3

Electrical specifications

Operating voltage U_B 150 V AC/DC

Operating current I_B 10 A

Ambient conditions

Ambient temperature -20 ... 125 °C (-4 ... 257 °F)

Storage temperature -15 ... 35 °C (5 ... 95 °F)

Pollution Degree 3

Mechanical specifications

Degree of protection IP67

Connection Solder connection for max. 1 mm²

Material

Contacts CuZn

Contact surface Ni/Au

Body CuZn

Slotted nut CuZn

Cable

Sheath diameter 2 mm ... 14.5 mm

Electrical connection

