

CE

### Model Number

#### AIR 16 S Einclipsbar Set

Bearing block for AIR17-S sensor module for installation in TopScan-S profile section

### Dimensions

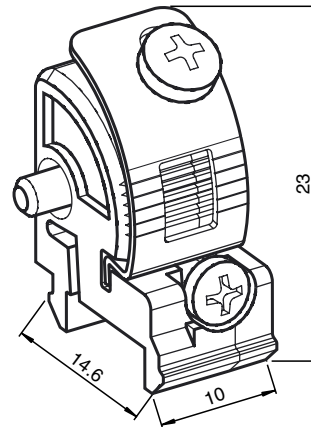

### Technical data

#### Mechanical specifications

Material	Polyamide, spring steel
Mass	approx. 5 g
Mounting	Mounting accessories included

#### General information

Packing unit	2 item(s)
--------------	-----------

#### Suitable series

Series	TopScan-S
--------	-----------