



**Model Number**

**ML71-55/59/82b/103/115b**

Retroreflective sensor  
with 0.2 m fixed cable and 4-pin, M12 connector

**Features**

- Reliable sensor for standard applications
- Miniature design with front optical face
- Automatic adjustment of sensitivity via TEACH-IN
- Resistant against noise: reliable operation under all conditions
- Clear and functional display concept for the operating modes
- Certified by ECOLAB

**Product information**

Small, robust, effective, and reliable - these are the properties of the ML7 sensor series. Due to their small size, number of versions, and two different lens positions, they are particularly suited for installation in tight spaces. The robust design and high quality of Pepperl+Fuchs mean they can also be used under harsh environmental conditions. The efficient technology, switching frequencies up to 1000 Hz, high resistance to ambient light, and 4-in-1 output make the series suitable for non-contact object detection.

Release date: 2013-04-18 15:17 Date of issue: 2013-05-13 209329\_eng.xml

**Dimensions**

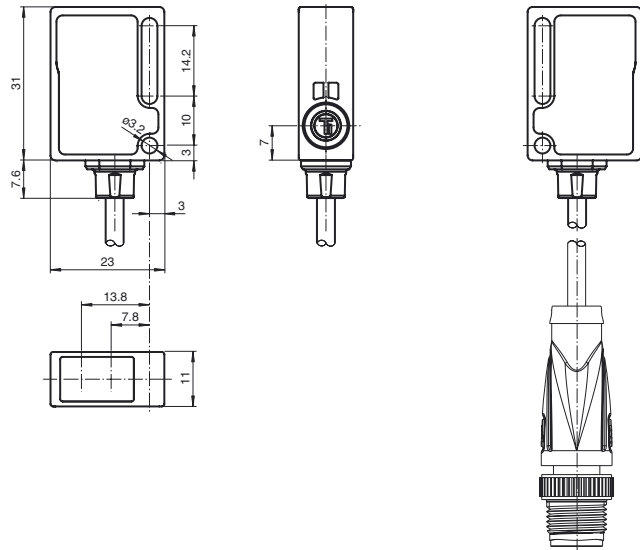

**Electrical connection**

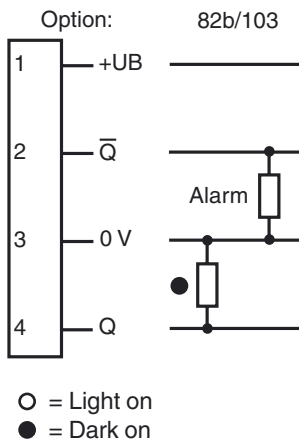

**Pinout**

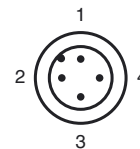

**Indicators/operating means**

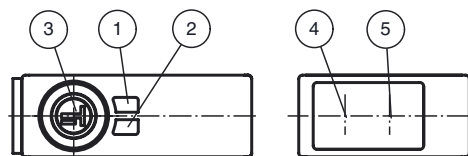

1	Operating display	green
2	Signal display	yellow
3	TEACH-IN button	
4	Emitter	
5	Receiver	

**Technical data****General specifications**

Effective detection range	0 ... 3 m
Reflector distance	0.03 ... 3 m
Threshold detection range	3.5 m
Reference target	H85-2 reflector
Light source	LED
Light type	modulated visible red light
Diameter of the light spot	approx. 180 mm at a distance of 3.5 m
Angle of divergence	approx. 3 °
Ambient light limit	40000 Lux

**Functional safety related parameters**

MTTF <sub>d</sub>	1530 a
Mission Time (T <sub>M</sub> )	20 a
Diagnostic Coverage (DC)	0 %

**Indicators/operating means**

Operating display	LED green, flashes in case of short-circuit
Function display	LED yellow, lights up when light beam is free, flashes when falling short of the stability control
Controls	TEACH-IN key

**Electrical specifications**

Operating voltage	U <sub>B</sub>	10 ... 30 V DC , class 2
Ripple		max. 10 %
No-load supply current	I <sub>0</sub>	< 20 mA

**Output**

Pre-fault indication output	1 PNP, inactive when level falls below function reserve after approx. 5 s. Immediately inactive if the beam is interrupted 4 times during the flashtime.	
Switching type	dark on	
Signal output	1 PNP output, short-circuit protected, reverse polarity protected, open collector	
Switching voltage	max. 30 V DC	
Switching current	max. 100 mA	
Voltage drop	U <sub>d</sub>	≤ 1.5 V DC
Switching frequency	f	1000 Hz
Response time		0.5 ms

**Ambient conditions**

Ambient temperature	-20 ... 60 °C (-4 ... 140 °F)
Storage temperature	-40 ... 75 °C (-40 ... 167 °F)

**Mechanical specifications**

Protection degree	IP67 / IP69K
Connection	fixed cable 200 mm with M12 connector, 4-pin
Material	
Housing	PC (glass-fiber-reinforced Makrolon)
Optical face	PMMA
Mass	approx. 30 g

**Compliance with standards and directives**

Standard conformity	
Product standard	EN 60947-5-2:2007 IEC 60947-5-2:2007
Standards	EN 50178, UL 508

**Approvals and certificates**

Protection class	II, rated voltage ≤ 250 V AC with pollution degree 1-2 according to IEC 60664-1
UL approval	cULus
CCC approval	CCC approval / marking not required for products rated ≤ 36 V

**Accessories**

**OMH-ML7-01**  
Mounting bracket

**OMH-ML7-02**  
Mounting bracket

**OMH-ML7-03**  
Fixing plate

Suitable reflectors and cable sockets can be found in the Internet

## Curves/Diagrams

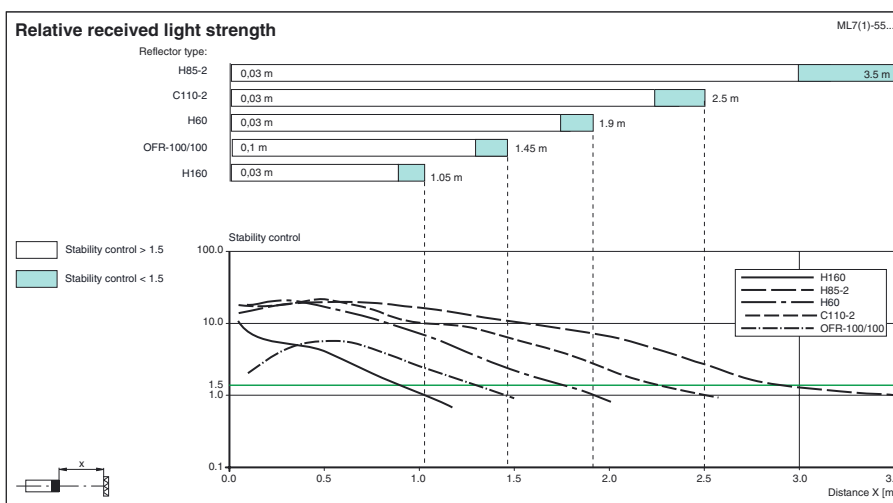
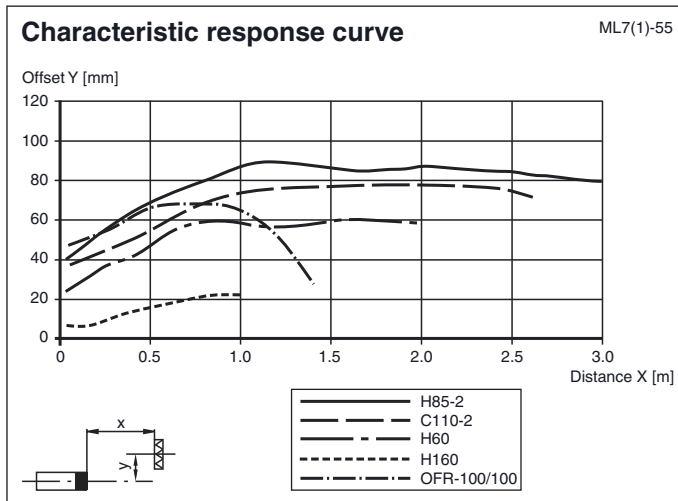

## Teach-In

Connect the sensor to operating voltage, the LED green lights up constantly. The sensor operates at max. sensitivity (delivery status) or with the last taught values.

Mount suitable reflector opposite light beam switch.

- Adjust the unit to the reflector.
- Press the Teach-In button - as an acknowledgement the green LED will quickly turn off one time.
- Press the Teach-In button until both LEDs green and yellow are blinking in parallel (2Hz). Release the Teach-In button now.
- While the green and yellow LEDs are blinking alternating (2 Hz) the unit is in the internal set up procedure.
- **Teach-In successful:** Both LEDs green and yellow are on. The unit is ready to use and in switching mode now.
- **Teach-In not successful:** Both LEDs are flashing alternating (4 Hz) for approx. 5 seconds. Afterwards the sensor returns to max. sensitivity setting. Please retry the Teach-In procedure beginning by step 1.