

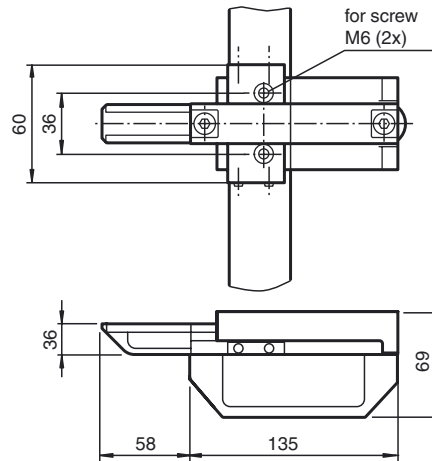

Dimensions



Technical data

Mechanical specifications

Material	GFK
Dimensions	Width 193 mm height 60 mm Depth 69 mm

General information

Scope of delivery	1 latch 1 actuator included
-------------------	--------------------------------

Model number

VAZ-IM1-BASE-BOLT-S

Latches for mechanical safety switches (LIM1 and IM1)

Features

- For left and right-mounted doors
- Latches to actuate the security switches

Function

In combination with the VAZ-IM1-BASE-S switch mount, the VAZ-IM1-BASE-BOLT S bar is a device for mounting safety switches onto commercially-available aluminum profiles and machine casings. The actuator, which is included in the scope of supply, is guided securely into the safety switch by the switch mount and the bar. The yellow color serves for quick recognition of the safety device. No further door handles are required because of the robust design. A slot enables the attachment of a lockout for additional security.

Matching system components

VAZ-IM1-BASE-S

Switch mount for mechanical safety switches (LIM1 and IM1)

Release date: 2008-11-13 11:00 Date of issue: 2014-01-13 210510_eng.xml