

Features

- 1-channel signal conditioner
- Universal usage at different power supplies
- 3-wire PNP/NPN sensor or push-pull input
- 2 relay contact outputs
- Adjustable energized/de-energized delay

Function

This signal conditioner converts the state of 3-wire sensors (PNP or NPN) or sensors with push-pull output stages into two relay outputs.

It has one input and two form C changeover relay outputs.

The switch amplifier has an adjustable energized/de-energized delay for the relay outputs.

The start-up time of the device is as long as the time setting value + 500 ms.

Assembly

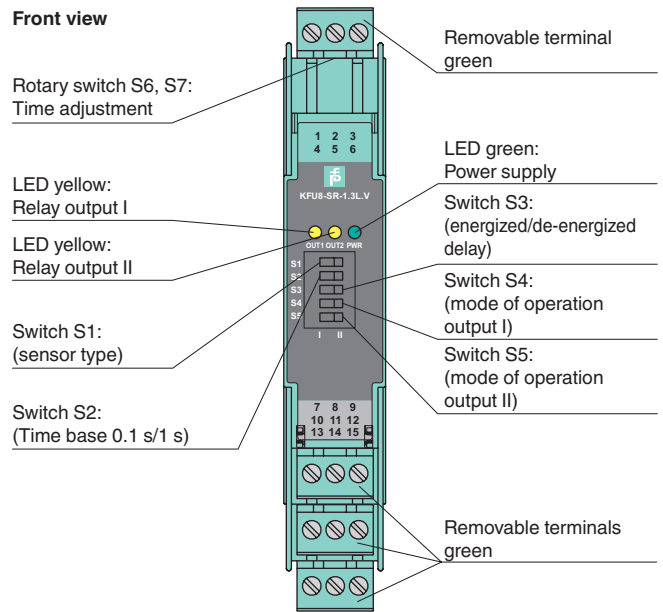

Connection

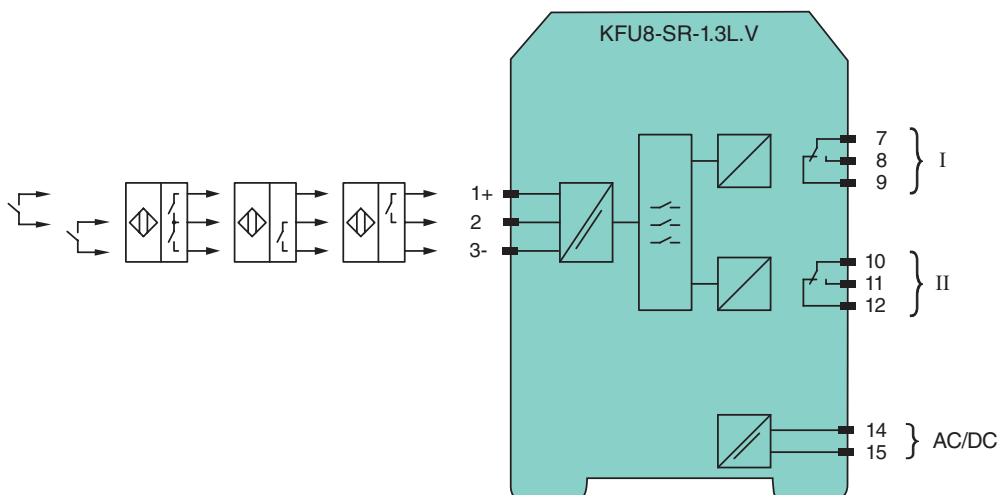

Release date 2010-11-11 13:09 Date of issue 2015-02-16 213968_eng.xml

Refer to "General Notes Relating to Pepperl+Fuchs Product Information".

Pepperl+Fuchs Group
www.pepperl-fuchs.com

USA: +1 330 486 0002
pa-info@us.pepperl-fuchs.com

Germany: +49 621 776 2222
pa-info@de.pepperl-fuchs.com

Singapore: +65 6779 9091
pa-info@sg.pepperl-fuchs.com

General specifications		
Signal type		Digital Input
Supply		
Connection		terminals 14, 15
Rated voltage	U_n	20 ... 48 V DC or 90 ... 253 V AC , 45 ... 65 Hz
Rated current	I_n	≤ 230 mA
Power loss		2.3 W
Power consumption		≤ 4.5 W
Input		
Connection		terminals 1+, 2, 3-
Rated values		22 ... 24 V DC / 100 mA , see additional information
Short-circuit current		≤ 125 mA
Switching point		PNP: 0-signal: < 12.5 V 1-signal: > 13.5 V NPN and push-pull output: 0-signal: < 4.5 V 1-signal: > 5.5 V
Output		
Connection		output I: terminals 7, 8, 9 output II: terminals 10, 11, 12
Output I, II		signal, relay
Contact loading		250 V AC / 2 A / $\cos \phi \geq 0.7$; 125 V AC/4 A/ $\cos \phi > 0.7$; 40 V DC / 2 A
Mechanical life		20 x 10 ⁶ switching cycles
Electrical life		0.2 x 10 ⁶ switching cycles (40 V DC, 2 A, ohmic) 0.4 x 10 ⁶ switching cycles (253 V AC, 2 A, $\cos \phi = 1$) 0.25 x 10 ⁶ switching cycles (253 V AC, 2 A, $\cos \phi = 0.7$)
Minimum load		50 mW, 5 V DC
Energized/De-energized delay		≤ 90 ms / ≤ 90 ms
Transfer characteristics		
Switching frequency		≤ 5 Hz for delay 0 s adjustable energized/de-energized delay: 0 ... 79 s
Electrical isolation		
Input/Output		reinforced insulation acc. to IEC 62103, rated insulation voltage 300 V _{rms}
Input/power supply		reinforced insulation acc. to IEC 62103, rated insulation voltage 300 V _{rms}
Output/power supply		reinforced insulation acc. to IEC 62103, rated insulation voltage 300 V _{rms}
Output/Output		reinforced insulation acc. to IEC 62103, rated insulation voltage 300 V _{rms}
Directive conformity		
Electromagnetic compatibility		
Directive 2004/108/EC		EN 61326-1:2006
Low voltage		
Directive 2006/95/EC		EN 61010-1:2001
Conformity		
Electromagnetic compatibility		NE 21:2006
Degree of protection		IEC 60529
Ambient conditions		
Ambient temperature		-20 ... 60 °C (-4 ... 140 °F)
Mechanical specifications		
Degree of protection		IP20
Mass		approx. 166 g
Dimensions		20 x 119 x 115 mm (0.8 x 4.7 x 4.5 in) , housing type B2
General information		
Supplementary information		Statement of Conformity, Declaration of Conformity, Attestation of Conformity and instructions have to be observed where applicable. For information see www.pepperl-fuchs.com .

Release date 2010-11-11 13:09 Date of issue 2015-02-16 213968_eng.xml

Function

The single-channel switch amplifier has one input and two relay outputs (change-over contacts). The input circuit can process signals from sensors that have either PNP/NPN output transistors or push-pull outputs. If sensors have NPN or push-pull outputs, switch S1 must be set to position I. If sensors have PNP output transistors, switch S1 must be set to position II.

The output switching characteristics (switch S4 for output I, switch S5 for output II) can be selected:

- Relay activated for closed sensor contact (for pull-push outputs, contact between terminals 2 and 3 closed) – switch S4 or S5 in position I.
- Relay deactivated for open sensor contact (for pull-push outputs, contact between terminals 2 and 3 open) – switch S4 or S5 in position II.

The switch amplifier has an adjustable energized/de-energized delay for the relay outputs.

Switch S3 = I activates the energized delay and switch S3 = II activates the de-energized delay. Depending on switch S2 (default time setting 0.1 s/1 s), the delay time can be set to between approx. 0.1 s and 7.9 s (for S2 = I) or between approx. 1 s and 79 s for (S2 = II) using switches S6 and S7.

The delay times add up to the shortest possible response times and have a tolerance of 10 %.

Switch S6 has a value range of 0 to 7, which is used to set the decimal power of the delay; switch S7 has a value range of 0 ... 9, which is used to set the single power of the delay. If the default time setting of S2 = I, S6 = 0 and S7 = 0, the response time constant of the switch amplifier for the undelayed slope (see switch position S3) is < 20 ms and for the delayed slope < 90 ms. These are the shortest possible response times.

Sensor connection

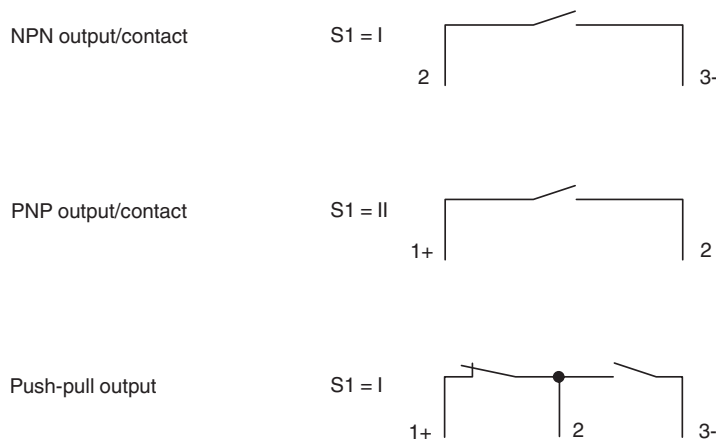

Note

The sensor currents are derated in line with the ambient temperature

The maximum value of the sensor currents is controlled by a thermal overload protection on the device.



Achtung

The device measures the ambient temperature and limits the sensor currents accordingly (see figure). An inadmissibly high ambient temperature can limit the function of the sensors.

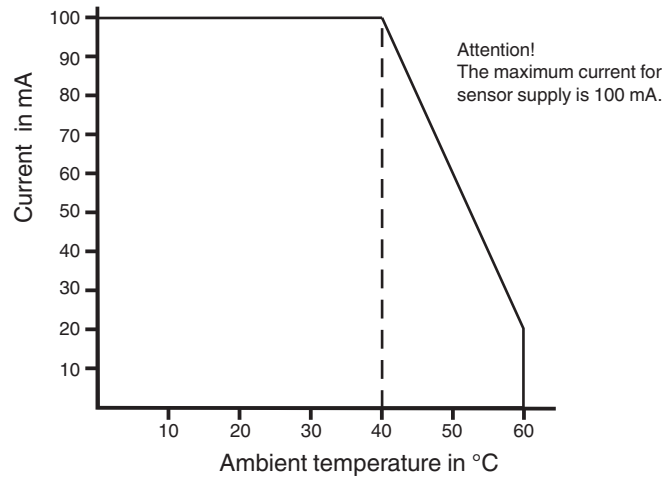

Configuration

Function of the DIP switch

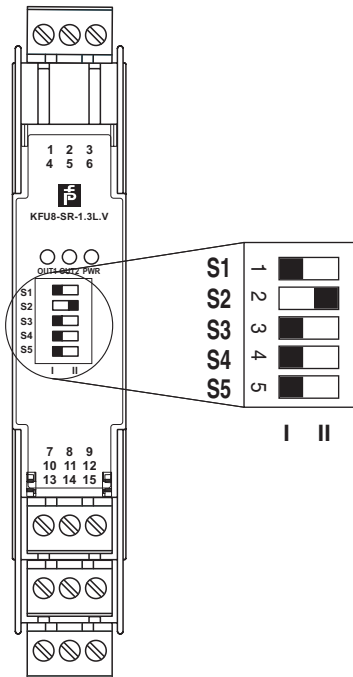

S	Function	Position
1	Input: Push-pull output, NO contact, NPN	I
	Input: PNP, NO contact	II
2	Default time = 0.1 s x (time setting value of switches S6 and S7)	I
	Default time = 1 s x (time setting value of switches S6 and S7)	II
3	ON delay, minimum input pulse length	I
	OFF delay, minimum output pulse length	II
4	Output I activated if sensor closed	I
	Output I activated if sensor open	II
5	Output II activated if sensor closed	I
	Output II activated if sensor open	II

Default setting: switches 1, 3, 4 and 5 to position I and switch 2 to position II

Function of the rotary switch

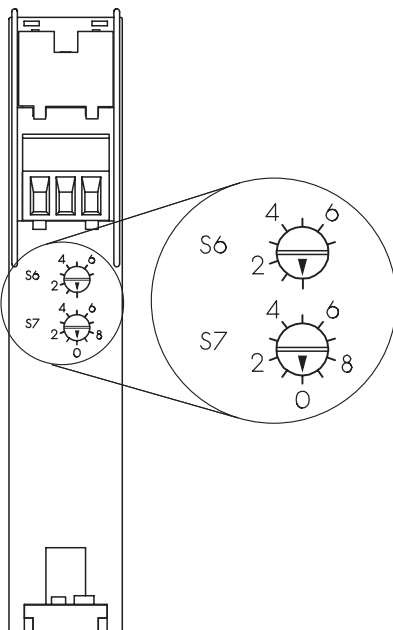

S	Function	Position
6	Decimal value 0 ... 7 x 10 x (default time setting value of switch S2)	0 ... 7
7	Decimal value 0 ... 9 x (default time setting value of switch S2)	0 ... 9

Default setting: switches 6 and 7 to position 0