

**Features**

- 2-channel signal conditioner
- 24 V DC supply (Power Rail)
- Dry contact or NAMUR inputs
- 2 active transistor outputs
- Reversible mode of operation
- Line fault detection (LFD)
- Housing width 12.5 mm
- Up to SIL2 acc. to IEC 61508

**Function**

This signal conditioner provides the galvanic isolation between field circuits and control circuits. The device transfers digital signals (NAMUR sensors or dry contacts) from the field to the control system. Each input controls an active transistor output. Via switches the mode of operation can be reversed and the line fault detection can be switched off. A fault is signaled by LEDs acc. to NAMUR NE44 and a separate collective error message output.

**Assembly**

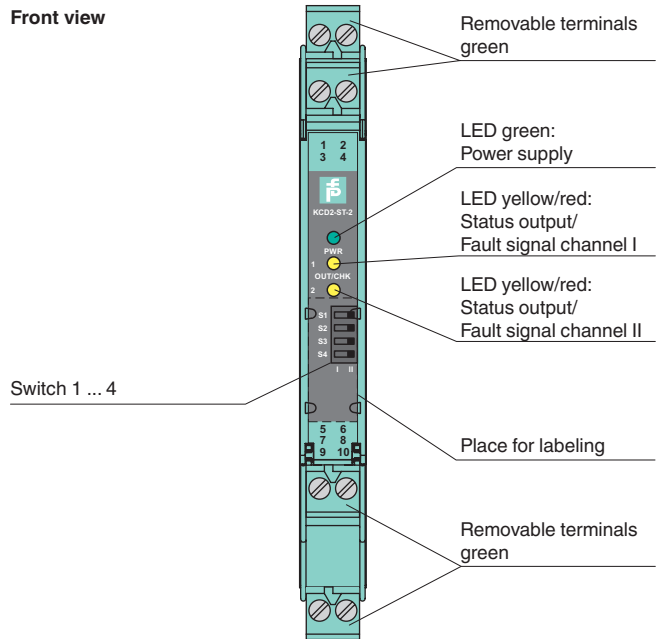

CE

SIL2

**Connection**

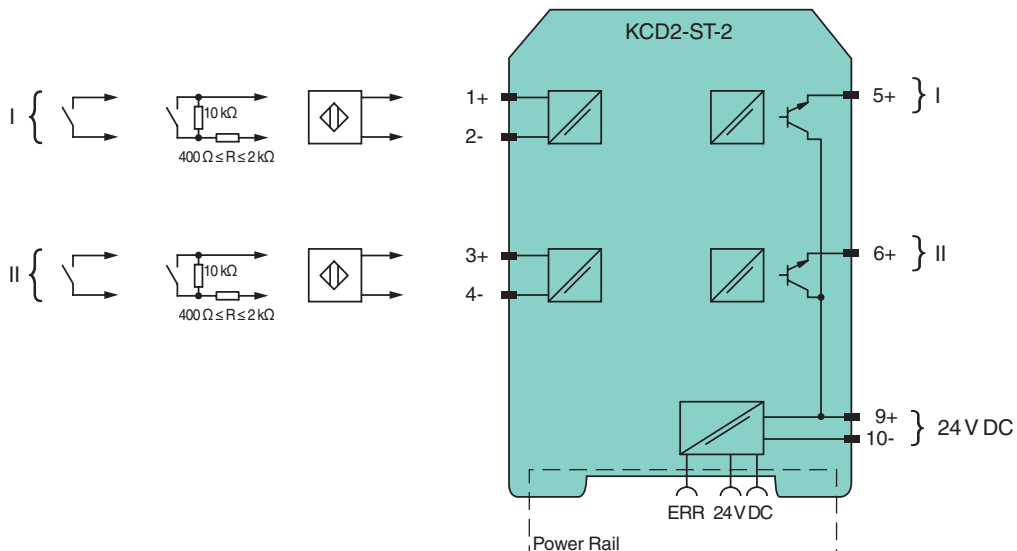

Release date 2013-08-07 17:26 Date of issue 2015-02-16 214247\_eng.xml

Refer to "General Notes Relating to Pepperl+Fuchs Product Information".

Pepperl+Fuchs Group  
www.pepperl-fuchs.com

USA: +1 330 486 0002  
pa-info@us.pepperl-fuchs.com

Germany: +49 621 776 2222  
pa-info@de.pepperl-fuchs.com

Singapore: +65 6779 9091  
pa-info@sg.pepperl-fuchs.com

<b>General specifications</b>		
Signal type		Digital Input
<b>Supply</b>		
Connection		Power Rail or terminals 9+, 10-
Rated voltage	$U_n$	19 ... 30 V DC
Ripple		≤ 10 %
Rated current	$I_n$	30 ... 20 mA + $I_{out}$
Power loss		≤ 800 mW including maximum power dissipation in the output
<b>Input</b>		
Connection		terminals 1+, 2-; 3+, 4-
Rated values		acc. to EN 60947-5-6 (NAMUR)
Open circuit voltage/short-circuit current		approx. 10 V DC / approx. 8 mA
Switching point/switching hysteresis		1.2 ... 2.1 mA / approx. 0.2 mA
Line fault detection		breakage $I \leq 0.1$ mA , short-circuit $I \geq 6.5$ mA
Pulse/Pause ratio		≥ 100 μs / ≥ 100 μs
<b>Output</b>		
Connection		terminals 5, 6
Rated voltage	$U_n$	30 V DC
Rated current	$I_n$	50 mA
Response time		≤ 200 μs
Signal level		1-signal: (supply voltage) - 3 V max. for 50 mA 0-signal: blocked output (off-state current ≤ 10 μA)
Output I		signal ; Transistor
Output II		signal ; Transistor
Collective error message		Power Rail
<b>Transfer characteristics</b>		
Switching frequency		≤ 5 kHz
<b>Electrical isolation</b>		
Input/Output		reinforced insulation acc. to EN 50178, rated insulation voltage 300 V <sub>eff</sub>
Input/power supply		reinforced insulation acc. to EN 50178, rated insulation voltage 300 V <sub>eff</sub>
Output/power supply		not available , common pole terminal 9+
Output/Output		not available , common pole terminal 9+
<b>Directive conformity</b>		
Electromagnetic compatibility		
Directive 2004/108/EC		EN 61326-1:2006
<b>Conformity</b>		
Electromagnetic compatibility		NE 21:2011
Degree of protection		IEC 60529:2001
Protection against electrical shock		IEC 61010-1:2010
Input		EN 60947-5-6:2000
<b>Ambient conditions</b>		
Ambient temperature		-20 ... 60 °C (-4 ... 140 °F)
<b>Mechanical specifications</b>		
Degree of protection		IP20
Mass		approx. 100 g
Dimensions		12.5 x 114 x 119 mm (0.5 x 4.5 x 4.7 in) , housing type A2
Mounting		on 35 mm DIN mounting rail acc. to EN 60715:2001
<b>General information</b>		
Supplementary information		Statement of Conformity, Declaration of Conformity, Attestation of Conformity and instructions have to be observed where applicable. For information see <a href="http://www.pepperl-fuchs.com">www.pepperl-fuchs.com</a> .

Release date 2013-08-07 17:26 Date of issue 2015-02-16 214247\_eng.xml

**Configuration**

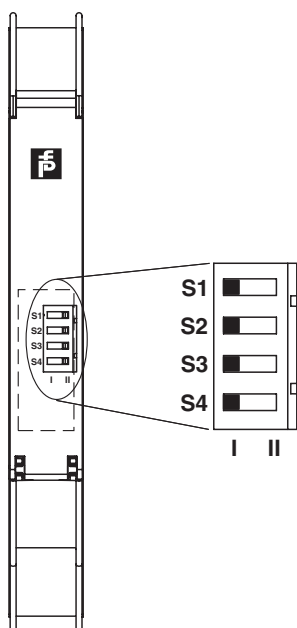

**Switch settings**

S	Function		Position
1	Mode of operation output I (active)	with high input current	I
		with low input current	II
2	Mode of operation output II (active)	with high input current	I
		with low input current	II
3	Line fault detection of the input I	ON	I
		OFF	II
4	Line fault detection of the input II	ON	I
		OFF	II

**Operating status**

Control circuit	Input signal
Initiator high impedance/contact opened	low input current
Initiator low impedance/contact closed	high input current
Lead breakage, lead short-circuit	Line fault

Factory settings: switch 1, 2, 3 and 4 in position I

**Accessories**

**Power feed module KFD2-EB2**

The power feed module is used to supply the devices with 24 V DC via the Power Rail. The fuse-protected power feed module can supply up to 150 individual devices depending on the power consumption of the devices. Collective error messages received from the Power Rail activate a galvanically-isolated mechanical contact.

**Power Rail UPR-03**

The Power Rail UPR-03 is a complete unit consisting of the electrical insert and an aluminium profile rail 35 mm x 15 mm. To make electrical contact, the devices are simply engaged.

**Profile Rail K-DUCT with Power Rail**

The profile rail K-DUCT is an aluminum profile rail with Power Rail insert and two integral cable ducts for system and field cables. Due to this assembly no additional cable guides are necessary.



*Power Rail and Profile Rail must not be fed via the device terminals of the individual devices!*