



Model Number

KC-LCDL-48-2R-24VDC

LCD batch controller with 2 relay outputs and 24 V_{DC} supply voltage

Features

- Counter/Timer/Tachometer
- Adding/subtracting via 2 separate inputs
- Batch controller with 2 pre-selections
- Easy-to-read backlit 2-line LCD display with icons for the displayed pre-selection and the status of both outputs
- Display range and preselection range from -999999 up to 999999
Overflow will be evaluated correctly up to 1 decade
- PNP and NPN sensors can be connected
- Protection degree IP65 (front only)

Technical data

General specifications

Pre-selection	2-fold
Data storage	> 10 years, EEPROM
Programming	keypad-driven menu

Functional safety related parameters

MTTF _d	410 a
Mission Time (T _M)	10 a
Diagnostic Coverage (DC)	0 %

Indicators/operating means

Type	2-line, 2 x 6-digit LC display with leading sign backlit
Display value	digit height 9 mm
Pre-selection	digit height 7 mm
Key interlock	via "high" potential at "LOCK" input
Decimal point	0 to max 5 fractional digits
Scale factor	0.0001 ... 99.9999
Reset	manually or external

Electrical specifications

Fusing	10 ... 30 V DC: T 0.2 A
Operating voltage	U _B 10 ... 30 V DC
Power consumption	P ₀ max. 1.5 W

Input

Connection	Counter inputs: A and B Control/reset inputs: LOCK, RESET, GATE, MPI
Signal voltage	
High	0.6 x U _e ... 30 V DC
Low	0 ... 0.2 x U _e
Counting frequency	30 Hz / 55 kHz
Minimum pulse duration	Control/reset inputs: 10 ms / 1 ms
Impedance	5 kOhm
Count modes	
Pulse counter	Counting with counting direction (cnt.dir), difference counting (up.dn), up/down counting (quad), Cumulative counting (up.up), up/down counting x 2 (quad 2), up/down counting x 4 (quad 4), additional functions for counter input A and counter input B: A/B, (A-B)/A x 100%
Frequency counter	functions for input A and input B: A, A-B, A+B quad, A/B, (A-B)/A x 100 %
Timer	Time measurement via GATE input (FrErun), counter input A: Start, counter input B: Stop (InpA.InpB.), counter input B: Start/Stop (InpB.InpB.), time measuring via RESET input (auto)

Output

Relay	changeover contact , Make contact
Switching voltage	max. 250 V AC / 110 V DC
Switching current	max. 3 A AC/DC, min. 30 mA DC,
Switch power	max. 750 VA / 90 W
Sensor supply	connected power supply is looped through, max. 80 mA
Output I	Relay with make contact, NC or NO progr.
Mechanical life	2 x 10 ⁷ switching cycles
Electrical life	1 x 10 ⁵ switching cycles at 3 A
Output II	Relay with changeover contact
Mechanical life	2 x 10 ⁷ switching cycles
Electrical life	5 x 10 ⁴ cycles at 3 A
Response time	Relay: approx. 7 ms Frequency counter: 100/600 ms

Ambient conditions

Ambient temperature	-20 ... 65 °C (-4 ... 149 °F)
Storage temperature	-25 ... 75 °C (-13 ... 167 °F)
Relative humidity	≤ 93 % at 40 °C (noncondensing)
Altitude	0 ... 2000 m

Mechanical specifications

Protection degree	IP65 (front)
Mass	approx. 138 g
Dimensions	48 mm x 48 mm x 109.8 mm

Compliance with standards and directives

Directive conformity	
EMC Directive 2004/108/EC	EN 61000-6-2:2005, EN 50295:1999
Standard conformity	
Emitted interference	DIN EN 55011:2009, Class B

Mech. capacity	EN 60068-2-6:2008 10 ... 55 Hz / 1 mm / XYZ 30 min in each direction
Shock and impact resistance	EN 60068-2-27:1995 100 G / 2 ms / XYZ 3 times in each direction

Release date: 2010-05-25 11:31 Date of issue: 2010-05-25 214737_ENG.xml

Dimensions

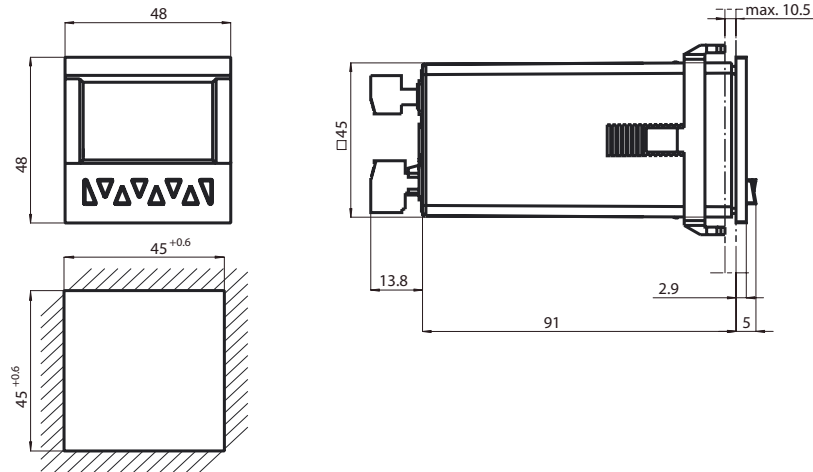

Indicators / Operating means

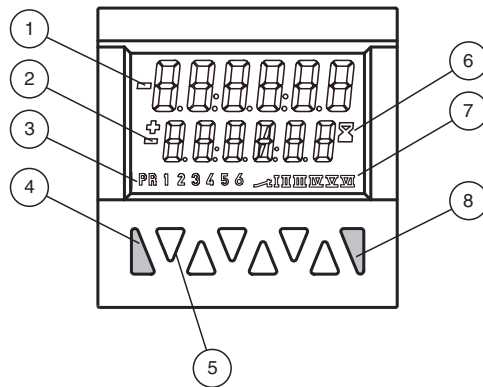

- 1 Current count value
- 2 Preset value
- 3 Indicator preset value (at 9)
- 4 Reset key
- 5 Decade keys 1 to 6 / Keys for programming
- 6 Run display for timer
- 7 Shows the active output
- 8 Prog/Mode key

Electrical connection

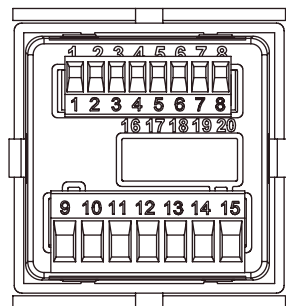

Signal and control inputs

- 1 Sensor supply voltage
- 2 GND (0V)
- 3 INP A (Signal input A)
- 4 INP B (Signal input B)
- 5 RESET (Reset input)
- 6 LOCK (Input Keypad lock)
- 7 GATE (Gate input)
- 8 MPI (User input)

Supply voltage and outputs

- 9 Relay contact C. } Output 1
- 10 Relay contact N.O. }
- 11 Relay contact C. } Output 2
- 12 Relay contact N.O. }
- 13 Relay contact N.C. }
- 14 10 ... 30 V DC } Supply voltage
- 15 GND (0V) }

Release date: 2010-05-25 11:31 Date of issue: 2010-05-25 214737_ENG.xml