

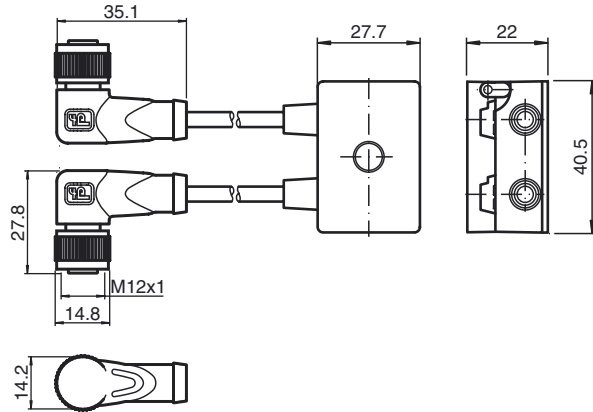

**Dimensions**

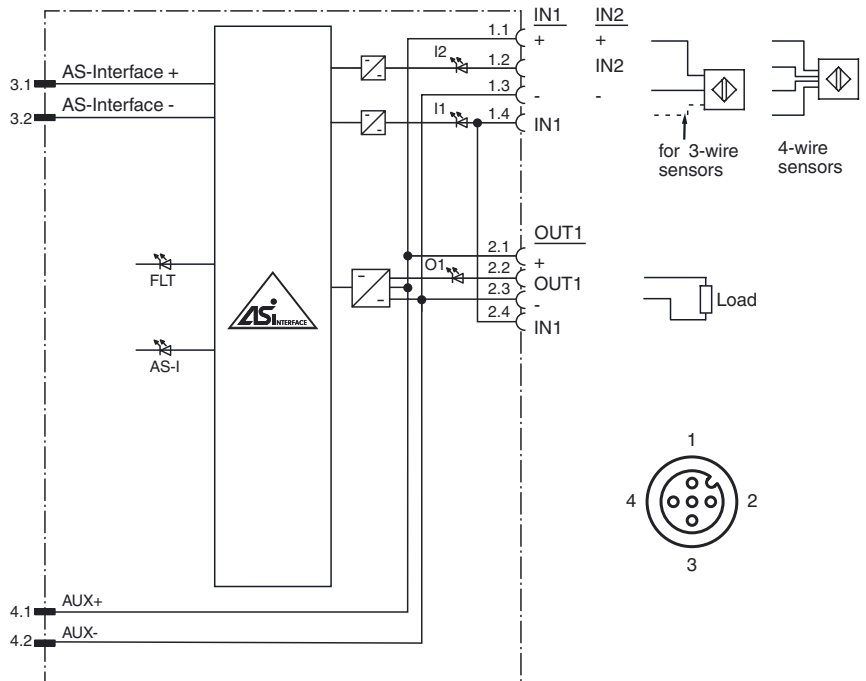

**Electrical connection**



**Model number**

**VBA-2E1A-G10-ZAL/E2L-1M-2V1-W**

G10 ultra compact module  
2 inputs and 1 output

**Features**

- Ultra-compact enclosure
- Gold-plated and machined contacts
- One piece housing
- Degree of protection IP68 / IP69K
- Direct connection via cable outlet

**Function**

The AS-Interface G10 ultra-compact module is suitable for the remote connection of sensors and actuators within very limited space. The one-piece enclosure has the protection degree IP68/IP69K.

The AS-Interface flat cable is contacted via pointy, gold-plated contact pins. The exact location of the pins on the lead is ensured by the swivel mechanism. Sensors and actuators are connected to the module via M12 sockets.

Multiple LEDs indicate the current status of the AS-Interface strand and the inputs and outputs and are used for diagnosis. The ultra-compact module is powered from  $U_{AUX}$ .

**Accessories**

**VAZ-PK-FK-0,2M-V1-W**

Adapter cable G10 module/hand-held programming device

**Indicating / Operating means**

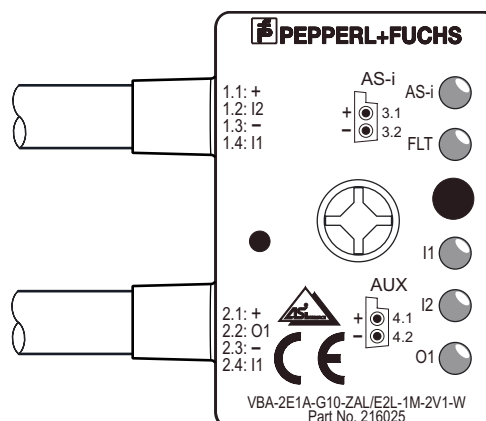

Release date: 2013-12-19 13:38 Date of issue: 2014-06-16 216025\_eng.xml

**Technical data****General specifications**

Slave type	A/B slave
AS-Interface specification	V3.0
Required master specification	≥ V2.1
UL File Number	E223772 "For use in NFPA 79 Applications only"

**Indicators/operating means**

LED FAULT	error display; LED red red: communication error or address is 0 red flashing: overload of sensor power supply or overload of outputs or external auxiliary voltage $U_{AUX}$ missing
LED AS-i	AS-Interface voltage; LED green
LED IN	switching state (input); 2 LED yellow
LED OUT	Switching state (output); LED yellow

**Electrical specifications**

Auxiliary voltage	$U_{AUX}$	20 ... 30 V DC PELV
Rated operating voltage	$U_e$	18.5 ... 31.6 V from AS-Interface
Rated operating current	$I_e$	≤ 40 mA / max. 60 mA
Protection class		III
Surge protection		$U_{AUX}$ , $U_{in}$ : Over voltage category III, safe isolated power supplies (PELV)

**Input**

Number/Type	2 inputs for 2- or 3-wire sensors (PNP), DC option 1 input for 4-wire sensor (PNP), DC
Supply	from external auxiliary voltage $U_{AUX}$
Voltage	20 ... 30 V
Current loading capacity	≤ 1000 mA overload and short-circuit resistant
Input current	≤ 9 mA (limited internally)
Switching point	according to DIN EN 61131-2 (Type 2)
0 (unattenuated)	≤ 3 mA
1 (attenuated)	≥ 5 mA
Signal delay	< 1 ms (input/AS-Interface)

**Output**

Number/Type	1 electronic output, PNP,
Supply	from external auxiliary voltage $U_{AUX}$
Voltage	≥ ( $U_{AUX} - 0.5$ V)
Current loading capacity	≤ 1000 mA overload and short-circuit resistant

**Programming instructions**

Profile	S-7.A.E
IO code	7
ID code	A
ID1 code	7
ID2 code	E

Data bits (function via AS-Interface)	input	output
D0	IN1	O1
D1	IN2	-
D2	-	-
D3	-	-

**Parameter bits (programmable via AS-i) function**

P0	communication monitoring P0 = 1 (basic setting), monitoring = ON, i.e. if communication fails, the outputs are de-energised P0 = 0, monitoring = OFF, if communication fails, the outputs maintain their condition
P1	Input filter P1 = 0 input filter on, pulse suppression ≤ 2 ms P1 = 1 input filter off (basic setting)
P2	Synchronous mode P2 = 0 synchronous mode on P2 = 1 synchronous mode off (basic setting)
P3	not used

**Ambient conditions**

Ambient temperature	-25 ... 70 °C (-13 ... 158 °F)
Storage temperature	-25 ... 85 °C (-13 ... 185 °F)
Shock and impact resistance	30 g, 11 ms in 6 spatial directions 3 shocks 10 g, 16 ms in 6 spatial directions 1000 shocks
Vibration resistance	0.75 mm 10 ... 57 Hz, 5 g 57 ... 150 Hz, 20 cycles

**Mechanical specifications**

Degree of protection	IP67 IP67 / IP68 / IP69K with flat cable VAZ-FK-S*
Connection	AS-Interface/ $U_{AUX}$ : AS-Interface flat cable In-/outputs & matching connector: M12 round connector, 4-pin, A-coded, according to IEC 61076-2-101:2012
Material	
Contacts	CuSn / Au
Housing	PBT PC
Body	black PUR
Cable	PUR

Mounting screw	Stainless steel 1.4305 / AISI 303	
<b>Cable</b>		
Sheath diameter	Ø4,3 mm	
Color	black	
Cores	4 x 0.34 mm <sup>2</sup>	
Length	L	1 m
Mass	100 g	
Tightening torque, fastening screws	1.65 Nm	
Tightening torque, cable gland	0.4 Nm	
<b>Compliance with standards and directives</b>		
Directive conformity		
EMC Directive 2004/108/EC	EN 50295:1999	
Standard conformity		
Noise immunity	EN 61000-6-2:2005, EN 61326-1:2006, EN 50295:1999	
Emitted interference	EN 61000-6-4:2007	
Input	EN 61131-2:2007	
Degree of protection	EN 60529:2000	
Fieldbus standard	EN 50295:1999, IEC 62026-2:2006	
<b>Approvals and certificates</b>		
UL approval	cULus Listed, Type 1 enclosure	
Maximum permissible ambient temperature	≤ 65 °C (≤ 149 °F)	

### Notes

Do not connect inputs and outputs, which are supplied via the module from AS-interface or via auxiliary power, with power supply and signal circuits with external potentials.

### Mounting instructions

You may screw the device onto a level mounting surface using two M4 attachment screws. The attachment screws are not included.

