

**Features**

- 1-channel isolated barrier
- 24 V DC supply (Power Rail)
- Dry contact or NAMUR inputs
- Usable as signal splitter (1 input and 2 outputs)
- Relay contact output
- Fault relay contact output
- Line fault detection (LFD)
- Housing width 12.5 mm
- Up to SIL2 acc. to IEC 61508

**Function**

This isolated barrier is used for intrinsic safety applications. It transfers digital signals (NAMUR sensors/mechanical contacts) from a hazardous area to a safe area.

The proximity sensor or switch controls a form A normally open relay contact for the safe area load. The normal output state can be reversed using switch S1. Switch S2 allows output II to be switched between a signal output and an error message output. Switch S3 enables or disables line fault detection of the field circuit.

During an error condition, relays revert to their de-energized state and LEDs indicate the fault according to NAMUR NE44.

A unique collective error messaging feature is available when used with the Power Rail system.

Due to its compact housing design and low heat dissipation, this device is useful for detecting positions, end stops, and switching states in space-critical applications.

**Assembly**

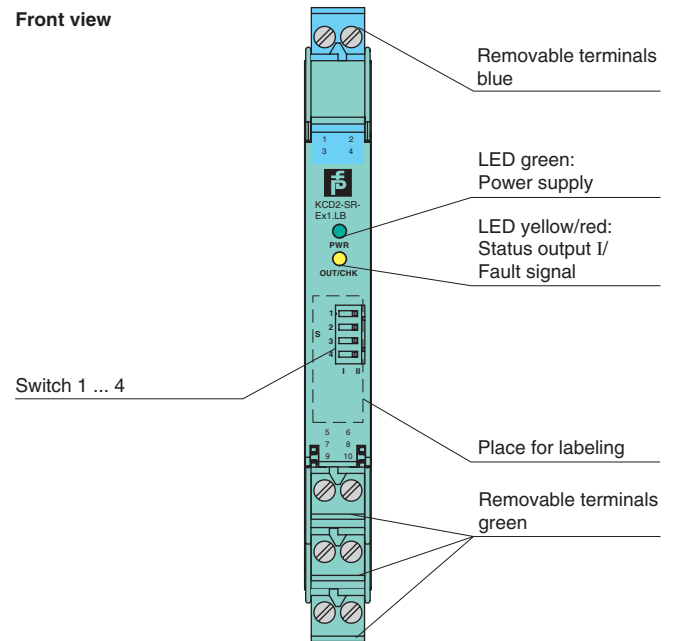

**Connection**

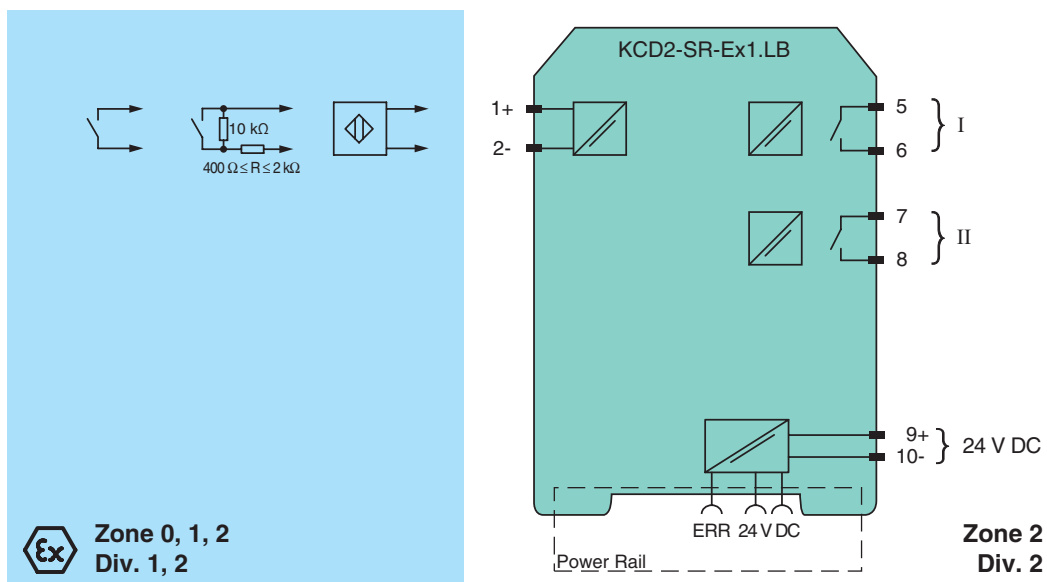

Release date 2015-02-18 15:30 Date of issue 2015-02-27 216712\_eng.xml

Refer to "General Notes Relating to Pepperl+Fuchs Product Information".

<b>General specifications</b>		
Signal type		Digital Input
<b>Supply</b>		
Connection		Power Rail or terminals 9+, 10-
Rated voltage	$U_n$	19 ... 30 V DC
Ripple		≤ 10 %
Rated current	$I_n$	≤ 30 mA
Power loss		≤ 500 mW
Power consumption		≤ 500 mW
<b>Input</b>		
Connection		terminals 1+, 2-
Rated values		acc. to EN 60947-5-6 (NAMUR)
Open circuit voltage/short-circuit current		approx. 10 V DC / approx. 8 mA
Switching point/switching hysteresis		1.2 ... 2.1 mA / approx. 0.2 mA
Line fault detection		breakage I ≤ 0.1 mA , short-circuit I ≥ 6.5 mA
Pulse/Pause ratio		≥ 20 ms / ≥ 20 ms
<b>Output</b>		
Connection		output I: terminals 5, 6 ; output II: terminals 7, 8
Output I		signal ; relay
Output II		signal or error message ; relay
Contact loading		253 V AC/2 A/cos φ > 0.7; 126.5 V AC/4 A/cos φ > 0.7; 30 V DC/2 A resistive load
Minimum switch current		2 mA / 24 V DC
Energized/De-energized delay		≤ 20 ms / ≤ 20 ms
Mechanical life		10 <sup>7</sup> switching cycles
<b>Transfer characteristics</b>		
Switching frequency		≤ 10 Hz
<b>Electrical isolation</b>		
Input/Output		reinforced insulation acc. to EN 50178, rated insulation voltage 300 V <sub>eff</sub>
Input/power supply		reinforced insulation acc. to EN 50178, rated insulation voltage 300 V <sub>eff</sub>
Output/power supply		reinforced insulation acc. to EN 50178, rated insulation voltage 300 V <sub>eff</sub>
Output/Output		reinforced insulation acc. to EN 50178, rated insulation voltage 300 V <sub>eff</sub>
<b>Directive conformity</b>		
Electromagnetic compatibility		
Directive 2004/108/EC		EN 61326-1:2013 (industrial locations)
Low voltage		
Directive 2006/95/EC		EN 61010-1:2010
<b>Conformity</b>		
Electromagnetic compatibility		NE 21
Degree of protection		IEC 60529:2001
<b>Ambient conditions</b>		
Ambient temperature		-20 ... 60 °C (-4 ... 140 °F)
<b>Mechanical specifications</b>		
Degree of protection		IP20
Mass		approx. 100 g
Dimensions		12.5 x 114 x 119 mm (0.5 x 4.5 x 4.7 in) , housing type A2
Mounting		on 35 mm DIN mounting rail acc. to EN 60715:2001
<b>Data for application in connection with Ex-areas</b>		
EC-Type Examination Certificate		BASEEFA 06 ATEX 0092 , for additional certificates see <a href="http://www.pepperl-fuchs.com">www.pepperl-fuchs.com</a>
Group, category, type of protection		⊕ II (1)G [Ex ia Ga] IIC , ⊕ II (1)D [Ex ia Da] IIIC , ⊕ I (M1) [Ex ia Ma] I
Input		[Ex ia Ga] IIC, [Ex ia Da] IIIC, [Ex ia Ma] I
Voltage	$U_o$	10.5 V
Current	$I_o$	17.1 mA
Power	$P_o$	45 mW (linear characteristic)
<b>Supply</b>		
Maximum safe voltage	$U_m$	253 V AC (Attention! $U_m$ is no rated voltage.)
<b>Output I, II</b>		
Maximum safe voltage	$U_m$	253 V AC (Attention! $U_m$ is no rated voltage.)
Contact loading		253 V AC/2 A/cos φ > 0.7; 126.5 V AC/4 A/cos φ > 0.7; 30 V DC/2 A resistive load
<b>Statement of conformity</b>		
Group, category, type of protection, temperature class		⊕ II 3G Ex nA nC IIC T4 Gc
<b>Output I, II</b>		
Contact loading		50 V AC/2 A/cos φ > 0.7; 30 V DC/2 A resistive load
<b>Electrical isolation</b>		

Release date 2015-02-18 15:30 Date of issue 2015-02-27 216712\_eng.xml

Refer to "General Notes Relating to Pepperl+Fuchs Product Information".

Pepperl+Fuchs Group  
www.pepperl-fuchs.com

USA: +1 330 486 0002  
pa-info@us.pepperl-fuchs.com

Germany: +49 621 776 2222  
pa-info@de.pepperl-fuchs.com

Singapore: +65 6779 9091  
pa-info@sg.pepperl-fuchs.com

Input/Output	safe electrical isolation acc. to IEC/EN 60079-11, voltage peak value 375 V
Input/power supply	safe electrical isolation acc. to IEC/EN 60079-11, voltage peak value 375 V
Directive conformity	
Directive 94/9/EC	EN 60079-0:2012+A11:2013 , EN 60079-11:2012 , EN 60079-15:2010
<b>International approvals</b>	
FM approval	
Control drawing	16-533FM-12 (cFMus)
UL approval	
Control drawing	16-533FM-12 (cULus)
IECEX approval	IECEX BAS 06.0025
Approved for	[Ex ia Ga] IIC, [Ex ia Da] IIIC, [Ex ia Ma] I
<b>General information</b>	
Supplementary information	EC-Type Examination Certificate, Statement of Conformity, Declaration of Conformity, Attestation of Conformity and instructions have to be observed where applicable. For information see <a href="http://www.pepperl-fuchs.com">www.pepperl-fuchs.com</a> .

Release date 2015-02-18 15:30 Date of issue 2015-02-27 216712\_eng.xml

Refer to "General Notes Relating to Pepperl+Fuchs Product Information".

Pepperl+Fuchs Group  
www.pepperl-fuchs.com

USA: +1 330 486 0002  
pa-info@us.pepperl-fuchs.com

Germany: +49 621 776 2222  
pa-info@de.pepperl-fuchs.com

Singapore: +65 6779 9091  
pa-info@sg.pepperl-fuchs.com

**Configuration**

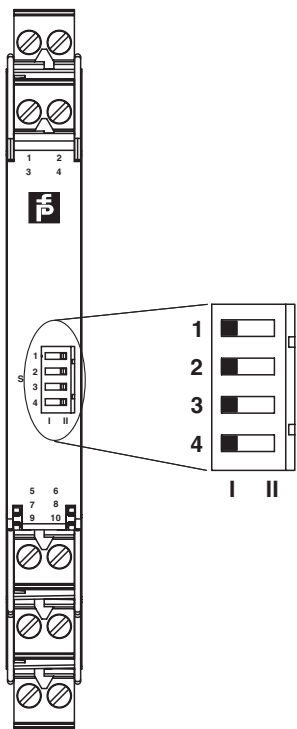

**Switch position**

S	Function		Position
1	Mode of operation Output I (relay) energized	with high input current	I
		with low input current	II
2	Assignment Output II (relay)	switching state like relay I	I
		fault signal output (de-energized if fault)	II
3	Line fault detection	ON	I
		OFF	II
4	no function		

**Operating status**

Control circuit	Input signal
Initiator high impedance/ contact opened	low input current
Initiator low impedance/ contact closed	high input current
Lead breakage, lead short-circuit	Line fault

Factory settings: switch 1, 2, 3 and 4 in position I

**Maximum switching power of output contacts**

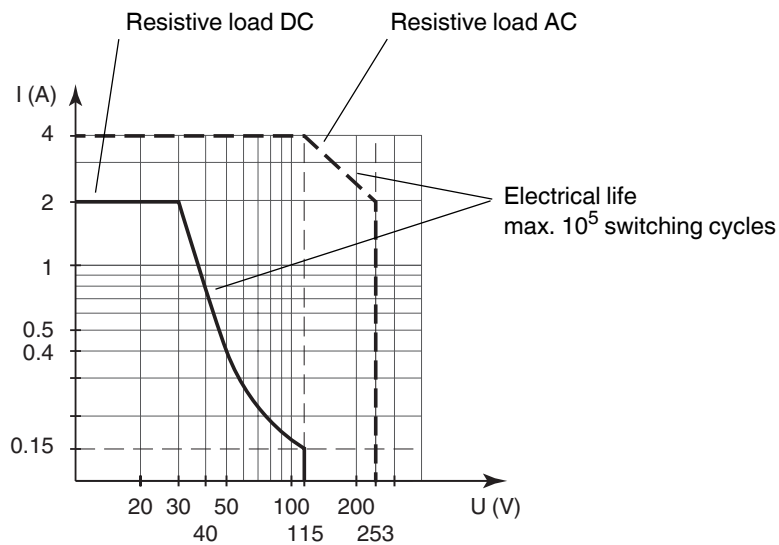

The maximum number of switching cycles is depending on the electrical load and may be higher when reduced currents and voltages are applied.

Release date 2015-02-18 15:30 Date of issue 2015-02-27 216712\_eng.xml

Refer to "General Notes Relating to Pepperl+Fuchs Product Information".

## Accessories

### Power feed module KFD2-EB2

The power feed module is used to supply the devices with 24 V DC via the Power Rail. The fuse-protected power feed module can supply up to 150 individual devices depending on the power consumption of the devices. Collective error messages received from the Power Rail activate a galvanically-isolated mechanical contact.

### Power Rail UPR-03

The Power Rail UPR-03 is a complete unit consisting of the electrical insert and an aluminium profile rail 35 mm x 15 mm. To make electrical contact, the devices are simply engaged.

### Profile Rail K-DUCT with Power Rail

The profile rail K-DUCT is an aluminum profile rail with Power Rail insert and two integral cable ducts for system and field cables. Due to this assembly no additional cable guides are necessary.



*Power Rail and Profile Rail must not be fed via the device terminals of the individual devices!*