



Features

- Accessory for WHA-*-F8B2-*
- Lithium thionyl chloride battery
- Voltage 7.2 V
- Capacity 19 Ah

Function

This battery is a battery pack containing 2 lithium metal batteries and is used for powering devices of type WHA-*-F8B2-*

The lithium thionyl chloride chemistry provides the highest possible capacity at the widest temperature range and is therefore predestined for usage also in rough environments.

Dimensions

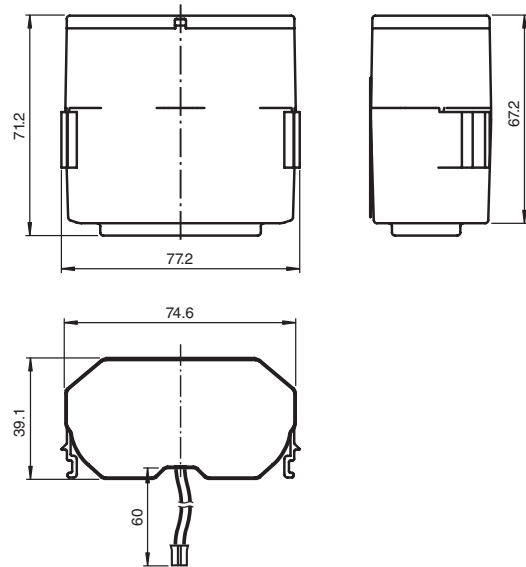

Technical data

Electrical specifications

Nominal voltage	U_n	7.2 V
Nominal current		250 mA
Nominal capacity		19 Ah , capacity can varies with usage conditions

Ambient conditions

Ambient temperature	-40 ... 80 °C (-40 ... 176 °F)
Storage temperature	15 ... 30 °C (59 ... 86 °F) recommended -40 ... 80 °C (-40 ... 176 °F) at accelerated derating

Mechanical specifications

Mass	approx. 285 g
Dimensions	75 x 71 x 39 mm (2.95 x 2.8 x 1.5 in)