



Model Number

BIS510-60-WH-F200A

Sheet inspection sensor for monitoring print by comparing stored images or barcode evaluation

Features

- Automatic learning of the reference image
- Automatic search for optimum image section
- Integrated error image memory
- Integrated illumination
- Image and barcode recognition with 10 page/s and a maximum sheet speed of 4 m/s

Function

The sheet identification sensor from Pepperl+Fuchs enables fast and simple monitoring of the correct sheet sequence in collating, folding and binding machines. Sheets can be monitored either by using the image comparison method or reading in barcodes printed on the sheets.

The device can be operated locally, as a stand-alone unit or in a network where several sensors are connected together. The sensor includes a camera, illumination unit and evaluating computer with digital input and output signals as well as a network interface.

Indicating / Operating means

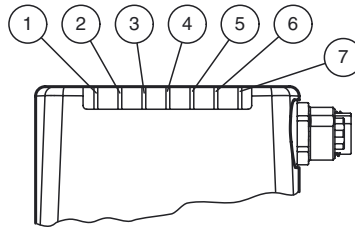

1	LED DIAG2	yellow
2	LED DIAG1	yellow
3	LED POWER	green
4	LED TEACH	yellow
5	LED BAD	yellow
6	LED GOOD	yellow
7	LED TRIGGER	yellow

Electrical connection

IO



Pin	Signal
1	OUT +UB
2	IN 1
3	GND
4	IN 2
5	OUT 1

LAN

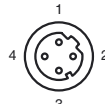

Pin	Signal
1	TX+ Ethernet
2	RX+ Ethernet
3	TX- Ethernet
4	RX- Ethernet

24 V DC+IO

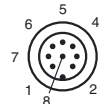

Pin	Signal
1	IN Trigger
2	+UB
3	OUT Good
4	OUT Bad
5	IN Start Teach
6	OUT Ready
7	GND
8	OUT Teach Active

Release date: 2014-07-25 11:20 Date of issue: 2014-07-25 220856_eng.xml

Refer to "General Notes Relating to Pepperl+Fuchs Product Information".

Pepperl+Fuchs Group
www.pepperl-fuchs.com

USA: +1 330 486 0001
fa-info@us.pepperl-fuchs.com

Germany: +49 621 776 4411
fa-info@de.pepperl-fuchs.com

Singapore: +65 6779 9091
fa-info@sg.pepperl-fuchs.com

Technical data**General specifications**

Light type	Integrated LED lightning (white)
Symbologies	2/5 interleaved, Code13, Code39, Code128, Pharmacode
Object size	25 mm x 25 mm
Read distance	55 mm
Depth of focus	± 5 mm
Reading field	65 mm x 40 mm
Evaluation frequency	10 Hz
Target velocity	triggered ≤ 4 m/s

Nominal ratings

Camera	
Type	CMOS , Global shutter
Number of pixels	752 x 480 pixels
Gray scale	256
Image recording	real-time , Program-controlled or triggered externally

Indicators/operating means

Operation indicator	LED green: Ready for operation
Control elements	2 x Button
LED indicator	Trigger, Good, Bad, Teach, Diag1, Diag2, PWR

Electrical specifications

Operating voltage	U_B	24 V DC ± 15% , PELV
No-load supply current	I_0	max. 250 mA
Power consumption	P_0	6 W

Interface 1

Interface type	Ethernet
Protocol	TCP/IP
Transfer rate	100 MBit/s
Cable length	max. 30 m

Input

Input voltage	to be applied externally 24 V ± 15% PELV
Number/Type	1 trigger input 1 teach input 2 input (IN1, IN2)
Input current	approx. 2 mA at 24 V DC
Switching threshold	low: < 10 V, high: > 15 V
Cable length	max. 30 m

Output

Number/Type	Teach active, Good, Bad, Ready
Switching type	PNP , short-circuit/overload protected
Switching voltage	to be applied externally 24 V ± 15% PELV
Switching current	max. 100 mA each output
Cable length	max. 30 m

Ambient conditions

Ambient temperature	0 ... 45 °C (32 ... 113 °F)
Storage temperature	-20 ... 60 °C (-4 ... 140 °F)
Relative humidity	80 % , noncondensing
Shock resistance	< 50 g
Vibration resistance	< 3 G , 11 ... 200 Hz

Mechanical specifications

Degree of protection	IP67
Connection	8-pin, M12x1 connector, standard (supply+IO) , 5-pin, M12x1 socket, standard (IO) , 4-pin, M12x1 socket, D-coded (LAN)

Material

Housing	PC/ABS
Optical face	Plastic pane
Installation	4 x M6 threading
Mass	approx. 160 g

Compliance with standards and directives

Standard conformity	
Noise immunity	EN 61326-1
Emitted interference	EN 61000-6-4
Degree of protection	EN 60529
Laser class	IEC 60825-1:2007

Accessories**V19-G-ABG-PG9**

Female connector, M12, 8-pin, shielded, field attachable

V19-G-2M-PUR-ABG

Female cordset, M12, 8-pin, shielded, PUR cable

V19-G-5M-PUR-ABG

Female cordset, M12, 8-pin, shielded, PUR cable

V1S-G

Male cordset, M12, 4-pin, field attachable

V1SD-G-2M-PUR-ABG-V45X-G

Connection cable, M12 to RJ-45, PUR cable 4-pin, CAT5e

V1SD-G-2M-PUR-ABG-V45-G

Connection cable, M12 to RJ-45, PUR cable 4-pin, CAT5e

V15-G-2M-PUR

Female cordset, M12, 5-pin, PUR cable

V15-G-5M-PUR

Female cordset, M12, 5-pin, PUR cable

V15-G-2M-PUR-V15-G

Connecting cable, M12 to M12, PUR cable 5-pin

V15S-G-5M-PUR-ABG

Male cordset, M12, 5-pin, shielded, PUR cable

BIS-VISUALIZER

User-Interface "BIS-Visualizer" for image display and basic parameters of the BIS devices

PCV-MB1

Mounting bracket for PCV* read head

Additional accessories can be found in the Internet.



Dimensions

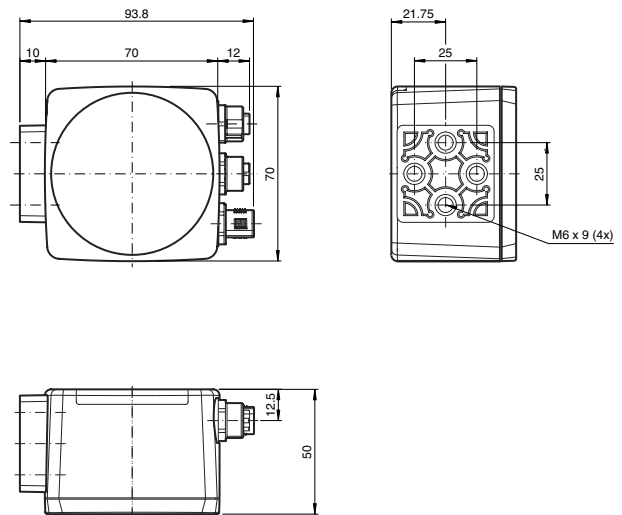

Release date: 2014-07-25 11:20 Date of issue: 2014-07-25 220856_eng.xml

Refer to "General Notes Relating to Pepperl+Fuchs Product Information".